

---

---

## Hexagon weld nuts with flange

*Écrous hexagonaux à souder, à embase*

**iTeh STANDARD PREVIEW**  
**(standards.iteh.ai)**

[ISO 21670:2003](https://standards.iteh.ai/catalog/standards/sist/247395e5-8556-4a14-a85c-b753d8c86929/iso-21670-2003)

<https://standards.iteh.ai/catalog/standards/sist/247395e5-8556-4a14-a85c-b753d8c86929/iso-21670-2003>



**PDF disclaimer**

This PDF file may contain embedded typefaces. In accordance with Adobe's licensing policy, this file may be printed or viewed but shall not be edited unless the typefaces which are embedded are licensed to and installed on the computer performing the editing. In downloading this file, parties accept therein the responsibility of not infringing Adobe's licensing policy. The ISO Central Secretariat accepts no liability in this area.

Adobe is a trademark of Adobe Systems Incorporated.

Details of the software products used to create this PDF file can be found in the General Info relative to the file; the PDF-creation parameters were optimized for printing. Every care has been taken to ensure that the file is suitable for use by ISO member bodies. In the unlikely event that a problem relating to it is found, please inform the Central Secretariat at the address given below.

**iTeh STANDARD PREVIEW**  
**(standards.iteh.ai)**

ISO 21670:2003

<https://standards.iteh.ai/catalog/standards/sist/247395e5-8556-4a14-a85c-b753d8c86929/iso-21670-2003>

© ISO 2003

All rights reserved. Unless otherwise specified, no part of this publication may be reproduced or utilized in any form or by any means, electronic or mechanical, including photocopying and microfilm, without permission in writing from either ISO at the address below or ISO's member body in the country of the requester.

ISO copyright office  
Case postale 56 • CH-1211 Geneva 20  
Tel. + 41 22 749 01 11  
Fax + 41 22 749 09 47  
E-mail [copyright@iso.org](mailto:copyright@iso.org)  
Web [www.iso.org](http://www.iso.org)

Published in Switzerland

## Foreword

ISO (the International Organization for Standardization) is a worldwide federation of national standards bodies (ISO member bodies). The work of preparing International Standards is normally carried out through ISO technical committees. Each member body interested in a subject for which a technical committee has been established has the right to be represented on that committee. International organizations, governmental and non-governmental, in liaison with ISO, also take part in the work. ISO collaborates closely with the International Electrotechnical Commission (IEC) on all matters of electrotechnical standardization.

International Standards are drafted in accordance with the rules given in the ISO/IEC Directives, Part 2.

The main task of technical committees is to prepare International Standards. Draft International Standards adopted by the technical committees are circulated to the member bodies for voting. Publication as an International Standard requires approval by at least 75 % of the member bodies casting a vote.

Attention is drawn to the possibility that some of the elements of this document may be the subject of patent rights. ISO shall not be held responsible for identifying any or all such patent rights.

ISO 21670 was prepared by Technical Committee ISO/TC 2, *Fasteners*.

## iTeh STANDARD PREVIEW (standards.iteh.ai)

[ISO 21670:2003](https://standards.iteh.ai/catalog/standards/sist/247395e5-8556-4a14-a85c-b753d8c86929/iso-21670-2003)

<https://standards.iteh.ai/catalog/standards/sist/247395e5-8556-4a14-a85c-b753d8c86929/iso-21670-2003>

**iTeh STANDARD PREVIEW**  
**(standards.iteh.ai)**

ISO 21670:2003

<https://standards.iteh.ai/catalog/standards/sist/247395e5-8556-4a14-a85c-b753d8c86929/iso-21670-2003>

# Hexagon weld nuts with flange

## 1 Scope

This International Standard specifies characteristics for hexagon weld nuts with flange, with sizes M5 to M16 (coarse thread) and M12 to M16 (fine thread), of product grade A.

Weld nuts conforming to this International Standard are suitable for use with bolts of property classes up to 10.9 in accordance with ISO 898-1.

## 2 Normative references

The following referenced documents are indispensable for the application of this document. For dated references, only the edition cited applies. For undated references, the latest edition of the referenced document (including any amendments) applies.

ISO 724, *ISO general-purpose metric screw threads — Basic dimensions*

ISO 898-1, *Mechanical properties of fasteners made of carbon steel and alloy steel — Part 1: Bolts, screws and studs*

ISO 898-2, *Mechanical properties of fasteners — Part 2: Nuts with specified proof load values — Coarse thread*

ISO 898-6, *Mechanical properties of fasteners — Part 6: Nuts with specified proof load values — Fine pitch thread*

ISO 965-3:1998, *ISO general purpose metric screw threads — Tolerances — Part 3: Deviations for constructional screw threads*

ISO 3269, *Fasteners — Acceptance inspection*

ISO 4759-1:2000, *Tolerances for fasteners — Part 1: Bolts, screws, studs and nuts — Product grades A, B and C*

ISO 8992, *Fasteners — General requirements for bolts, screws, studs and nuts*

3 Dimensions

Nut dimensions shall be as given in Figure 1 and Table 1.

Dimensions in millimetres

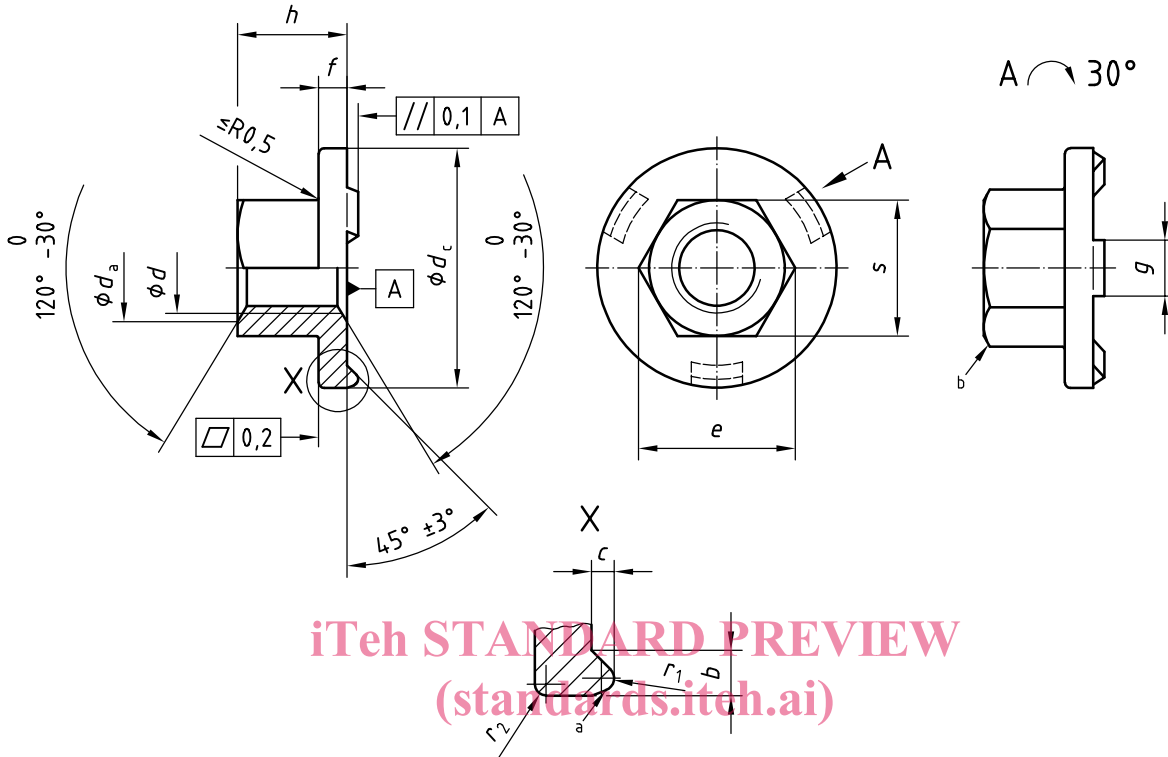

iTeh STANDARD PREVIEW  
(standards.itih.ai)

ISO 21670:2003

a Pressing contour.

[https://standards.itih.ai/catalog/standards/sist/247395e5-8556-4a14-a85c-](https://standards.itih.ai/catalog/standards/sist/247395e5-8556-4a14-a85c-b753d8c86929/iso-21670-2003)

b Pressing contour, at least 15°.

[b753d8c86929/iso-21670-2003](https://standards.itih.ai/catalog/standards/sist/247395e5-8556-4a14-a85c-b753d8c86929/iso-21670-2003)

Figure 1 — Nut dimensions

Table 1 — Nut dimensions

Dimensions in millimetres

Thread size (d)	$(d \times P_1^a)$	$P_2^b$	b	c	$d_a$	$d_c$	e	f	g	h		s	$r_1$	$r_2$	Approx. mass ( $\rho = 7,85 \text{ kg/dm}^3$ ) per 1 000 pieces in kg
										min.	max.				
M5	—	0,8	2,2	0,8	6	15,5	8,2	1,7	4	4,7	5,0	8	0,6	0,3	2,9
M6	—	1	2,7	0,8	7	18,5	10,6	2	5	6,64	7,00	10	0,6	0,5	5,7
M8	—	1,25	2,7	1	9,5	22,5	13,6	2,5	6	9,64	10,00	13	0,8	0,8	12,2
M10	—	1,5	2,95	1,2	11,5	26,5	16,9	3	7	12,57	13,00	16	1	1	21,8
M12	M12 × 1,5	1,75	3,2	1,2	14	30,5	19,4	3	8	14,57	15,00	18	1	1,2	29,4
M14	M14 × 1,5	2	3,45	1,2	16	33,5	22,4	4	8	16,16	17,00	21	1	1,2	45,8
M16	M16 × 1,5	2	3,7	1,2	18	36,5	25	4	8	18,66	19,50	24	1	1,2	63,1

a  $P_1$  is the pitch of the fine pitch thread.

b  $P_2$  is the pitch of the coarse pitch thread.

## 4 Technical delivery conditions

### 4.1 General requirements

General requirements are specified in ISO 8992.

### 4.2 Material

Weld nuts with flange shall be made of steel with a maximum carbon content of 0,25 %.

If quenching and tempering of the nuts is required, the hardness shall not exceed 300 HV.

Use of free-cutting steel is not permissible.

If a specific steel is required, this shall be agreed on ordering.

### 4.3 Tolerances

Weld nuts with flange shall be of product grade A in accordance with ISO 4759-1:2000, with threads in accordance with ISO 724, however, with tolerance class 6G in accordance with ISO 965-3:1998.

### 4.4 Mechanical properties

Weld nuts in accordance with this International Standard shall meet the proof load values as specified in Table 2. The proof load test shall be in accordance with ISO 898-2 or ISO 898-6 as appropriate. In case of dispute, welding projections shall be removed prior to testing.

Table 2 — Proof load values

Coarse pitch thread ( <i>d</i> )	Proof load N	Fine pitch thread ( <i>d</i> × <i>P</i> <sub>1</sub> )	Proof load N
<b>M5</b>	14 800	—	—
<b>M6</b>	20 900	—	—
<b>M8</b>	38 100	—	—
<b>M10</b>	60 300	—	—
<b>M12</b>	88 500	<b>M12 × 1,5</b>	92 900
<b>M14</b>	120 800	<b>M14 × 1,5</b>	131 900
<b>M16</b>	164 900	<b>M16 × 1,5</b>	176 200

### 4.5 Surface finish

Hexagon weld nuts with flange are delivered uncoated.

Since uncoated weld nuts may be affected by corrosion during transport or storage, the manufacturer shall prove corrosion protection that does not impair nut weldability.

### 4.6 Acceptance inspection

Acceptance inspection shall comply with the specifications given in ISO 3269.

## 5 Designation

EXAMPLE 1 A hexagon weld nut with flange, thread M10, made of steel, not quenched and tempered, which is suitable for use with a corresponding bolt or screw of property class 10.9, is designated as follows:

**Weld nut ISO 21670 - M10 - St**

If a quenched and tempered weld nut is agreed, the symbol QT shall be added to the designation.

EXAMPLE 2 A hexagon weld nut with flange, thread M12 × 1,5, made of steel, quenched and tempered, which is suitable for use with a corresponding bolt or screw of property class 10.9, is designated as follows:

**Weld nut ISO 21670 - M12 × 1,5 - St - QT**

## 6 Marking

Hexagon weld nuts with flange of size M5 or greater shall be marked with the manufacturer's mark. The marking shall be at the nut face which is opposite to the flange.

## 7 Connecting dimensions

See Figure 2 and Table 3.

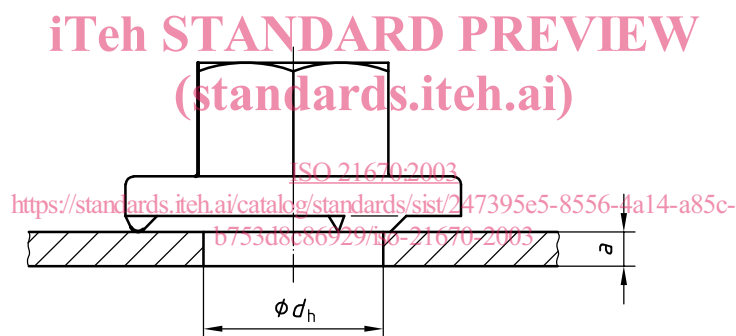

Figure 2 — Connecting dimensions (nut not welded on)

Table 3 — Connecting dimensions

Thread size as in Table 1		Plate thickness		Hole diameter $d_h$ H11
$(d)$	$(d \times P_1)$	min.	max.	
M5	—	0,88	1,20	7
M6	—	0,88	1,80	8
M8	—	1	2	10,5
M10	—	1,25	2,50	12,5
M12	M12 × 1,5	1,5	3,0	14,8
M14	M14 × 1,5	2,0	3,5	16,8
M16	M16 × 1,5	2	4	18,8



**iTeh STANDARD PREVIEW**  
**(standards.iteh.ai)**

ISO 21670:2003

<https://standards.iteh.ai/catalog/standards/sist/247395e5-8556-4a14-a85c-b753d8c86929/iso-21670-2003>