



Rolling bearings — Radial bearings — Boundary dimensions — General plan

Roulements — Roulements radiaux — Dimensions d'encombrement — Plan général

First edition — 1981-12-15

iTeh STANDARD PREVIEW
(standards.itih.ai)

ISO 15:1981

<https://standards.itih.ai/catalog/standards/sist/d2b36fe-5676-440f-aefc-f4ea01a5e0c0/iso-15-1981>

Foreword

ISO (the International Organization for Standardization) is a worldwide federation of national standards institutes (ISO member bodies). The work of developing International Standards is carried out through ISO technical committees. Every member body interested in a subject for which a technical committee has been set up has the right to be represented on that committee. International organizations, governmental and non-governmental, in liaison with ISO, also take part in the work.

Draft International Standards adopted by the technical committees are circulated to the member bodies for approval before their acceptance as International Standards by the ISO Council.

International Standard ISO 15 was developed by Technical Committee ISO/TC 4, *Rolling bearings*, and was circulated to the member bodies in January 1981.

It has been approved by the member bodies of the following countries :

Australia	Hungary	Romania
Austria	India	South Africa, Rep. of
Brazil	Italy	Spain
Canada	Japan	Sweden
China	Korea, Dem. P. Rep. of	Switzerland
Czechoslovakia	Korea, Rep. of	United Kingdom
Egypt, Arab Rep. of	Mexico	USA
France	Netherlands	USSR
Germany, F. R.	Poland	

No member body expressed disapproval of the document.

This International Standard cancels and replaces ISO Recommendations R 15/1-1968 and R 15/2-1970, of which it constitutes a technical revision.

Rolling bearings — Radial bearings — Boundary dimensions — General plan

iTeh STANDARD PREVIEW

(standards.iteh.ai)

0 Introduction

The object of the general plan is to restrict the number of radial bearing sizes enough to ensure economic production and yet to provide a sufficient number of sizes to satisfy present and future needs of bearing users. These needs are very comprehensive and varying. Therefore the plan has to embrace a wide range of numerically determined sizes and proportions and may even be extended by ISO in accordance with the rules given in the annex.

1 Scope and field of application

This International Standard lays down preferred boundary dimensions for radial bearings.

The tapered roller bearings, insert bearings and some types of needle roller bearings standardized by ISO do not conform with this general plan since the dimensions given were not found optimal for the bearings in question.

As all bearings of the dimensions given in the general plan may not be in production at any particular time, it is advisable for users to approach bearing manufacturers during the early

stages of design for information regarding availability of the bearings.

The chamfer dimensions given in tables 1 to 8 do not necessarily apply to

- a) the groove side of bearing rings with snap ring groove;
- b) the non-rib side of thin cylindrical roller bearing rings;
- c) the non-thrust side of angular contact bearing rings;
- d) inner rings of bearings with tapered bore.

The general plan does not contain any recommendations pertaining to the internal design of bearings.

2 References

ISO 3, *Preferred numbers — Series of preferred numbers.*

ISO 582, *Rolling bearings — Metric series — Chamfer dimension limits.*

3 Symbols

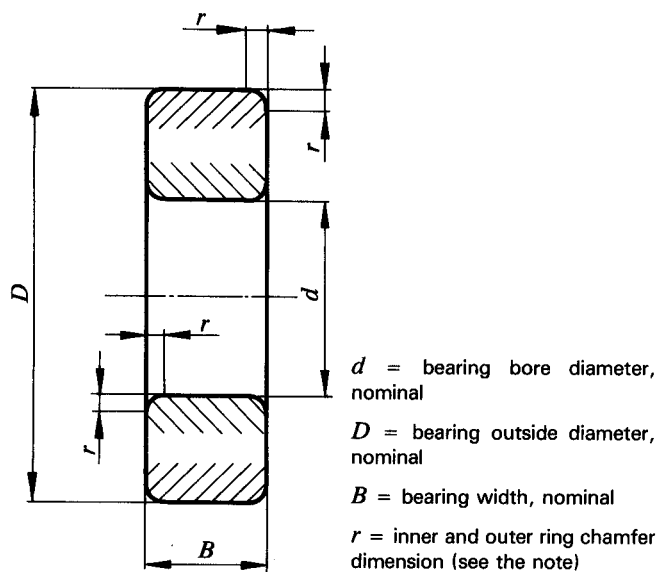

NOTE — The values for inner and outer ring chamfer dimensions given in the plan are minimum limits, $r_{s \text{ min}}$.

The corresponding maximum limits are given in ISO 582.

The exact shape of the chamfer surface is not specified, but its contour in an axial plane shall not be allowed to project beyond the imaginary circular arc of radius $r_{s \text{ min}}$ tangential to the ring face and the bore or outside cylindrical surface of the ring.

ISO 15:1981

4 Boundary dimensions <https://standards.iteh.ai/catalog/standards/sist/d2b36fe-5676-440f-aefc-f4ea01a5e0c0/iso-15-1981>

Table 1 — Diameter series 7

Dimensions in millimetres

d	D	Dimension series		
		17	37	17 and 37
		B		$r_{s \text{ min}}$
0,6	2	0,8	—	0,05
1	2,5	1	—	0,05
1,5	3	1	1,8	0,05
2	4	1,2	2	0,05
2,5	5	1,5	2,3	0,08
3	6	2	3	0,08
4	7	2	3	0,08
5	8	2	3	0,08
6	10	2,5	3,5	0,1
7	11	2,5	3,5	0,1
8	12	2,5	3,5	0,1
9	14	3	4,5	0,1
10	15	3	4,5	0,1
12	18	4	5	0,2
15	21	4	5	0,2
17	23	4	5	0,2
20	27	4	5	0,2
25	32	4	5	0,2
30	37	4	5	0,2

Table 2 — Diameter series 8

Dimensions in millimetres

d	D	Dimension series									
		08	18	28	38	48	58	68	08	18-68	
		B							r _s min		
0,6	2,5	—	1	—	1,4	—	—	—	—	—	0,05
1	3	—	1	—	1,5	—	—	—	—	—	0,05
1,5	4	—	1,2	—	2	—	—	—	—	—	0,05
2	5	—	1,5	—	2,3	—	—	—	—	—	0,08
2,5	6	—	1,8	—	2,6	—	—	—	—	—	0,08
3	7	—	2	—	3	—	—	—	—	—	0,1
4	9	—	2,5	3,5	4	—	—	—	—	—	0,1
5	11	—	3	4	5	—	—	—	—	—	0,15
6	13	—	3,5	5	6	—	—	—	—	—	0,15
7	14	—	3,5	5	6	—	—	—	—	—	0,15
8	16	—	4	5	6	8	—	—	—	—	0,2
9	17	—	4	5	6	8	—	—	—	—	0,2
10	19	—	5	6	7	9	—	—	—	—	0,3
12	21	—	5	6	7	9	—	—	—	—	0,3
15	24	—	5	6	7	9	—	—	—	—	0,3
17	26	—	5	6	7	9	—	—	—	—	0,3
20	32	4	7	8	10	12	16	22	0,3	0,3	0,3
22	34	4	7	—	10	—	16	22	0,3	0,3	0,3
25	37	4	7	8	10	12	16	22	0,3	0,3	0,3
28	40	4	7	—	10	—	16	22	0,3	0,3	0,3
30	42	4	7	—	10	12	16	22	0,3	0,3	0,3
32	44	4	7	—	10	—	16	22	0,3	0,3	0,3
35	47	4	7	8	10	12	16	22	0,3	0,3	0,3
40	52	4	7	8	10	12	16	22	0,3	0,3	0,3
45	58	4	7	8	10	13	18	23	0,3	0,3	0,3
50	65	5	7	10	12	15	20	27	0,3	0,3	0,3
55	72	7	9	11	13	17	23	30	0,3	0,3	0,3
60	78	7	10	12	14	18	24	32	0,3	0,3	0,3
65	85	7	10	13	15	20	27	36	0,3	0,6	0,6
70	90	8	10	13	15	20	27	36	0,3	0,6	0,6
75	95	8	10	13	15	20	27	36	0,3	0,6	0,6
80	100	8	10	13	15	20	27	36	0,3	0,6	0,6
85	110	9	13	16	19	25	34	45	0,3	1	1
90	115	9	13	16	19	25	34	45	0,3	1	1
95	120	9	13	16	19	25	34	45	0,3	1	1
100	125	9	13	16	19	25	34	45	0,3	1	1
105	130	9	13	16	19	25	34	45	0,3	1	1
110	140	10	16	19	23	30	40	54	0,6	1	1
120	150	10	16	19	23	30	40	54	0,6	1	1
130	165	11	18	22	26	35	46	63	0,6	1,1	1,1
140	175	11	18	22	26	35	46	63	0,6	1,1	1,1
150	190	13	20	24	30	40	54	71	0,6	1,1	1,1
160	200	13	20	24	30	40	54	71	0,6	1,1	1,1
170	215	14	22	27	34	45	60	80	0,6	1,1	1,1
180	225	14	22	27	34	45	60	80	0,6	1,1	1,1

Table 2 (concluded)

Dimensions in millimetres

d	D	Dimension series								
		08	18	28	38	48	58	68	08	18-68
		B							r _s min	
190	240	16	24	30	37	50	67	90	1	1,5
200	250	16	24	30	37	50	67	90	1	1,5
220	270	16	24	30	37	50	67	90	1	1,5
240	300	19	28	36	45	60	80	109	1	2
260	320	19	28	36	45	60	80	109	1	2
280	350	22	33	42	52	69	95	125	1,1	2
300	380	25	38	48	60	80	109	145	1,5	2,1
320	400	25	38	48	60	80	109	145	1,5	2,1
340	420	25	38	48	60	80	109	145	1,5	2,1
360	440	25	38	48	60	80	109	145	1,5	2,1
380	480	31	46	60	75	100	136	180	2	2,1
400	500	31	46	60	75	100	136	180	2	2,1
420	520	31	46	60	75	100	136	180	2	2,1
440	540	31	46	60	75	100	136	180	2	2,1
460	580	37	56	72	90	118	160	218	2,1	3
480	600	37	56	72	90	118	160	218	2,1	3
500	620	37	56	72	90	118	160	218	2,1	3
530	650	37	56	72	90	118	160	218	2,1	3
560	680	37	56	72	90	118	160	218	2,1	3
600	730	42	60	78	98	128	175	236	3	3
630	780	48	69	88	112	150	200	272	3	4
670	820	48	69	88	112	150	200	272	3	4
710	870	50	74	95	118	160	218	290	4	4
750	920	54	78	100	128	170	230	308	4	5
800	980	57	82	106	136	180	243	325	4	5
850	1 030	57	82	106	136	180	243	325	4	5
900	1 090	60	85	112	140	190	258	345	5	5
950	1 150	63	90	118	150	200	272	355	5	5
1 000	1 220	71	100	128	165	218	300	400	5	6
1 060	1 280	71	100	128	165	218	300	400	5	6
1 120	1 360	78	106	140	180	243	325	438	5	6
1 180	1 420	78	106	140	180	243	325	438	5	6
1 250	1 500	80	112	145	185	250	335	450	6	6
1 320	1 600	88	122	165	206	280	375	500	6	6
1 400	1 700	95	132	175	224	300	400	545	6	7,5
1 500	1 820	—	140	185	243	315	—	—	—	7,5
1 600	1 950	—	155	200	265	345	—	—	—	7,5
1 700	2 060	—	160	206	272	355	—	—	—	7,5
1 800	2 180	—	165	218	290	375	—	—	—	9,5
1 900	2 300	—	175	230	300	400	—	—	—	9,5
2 000	2 430	—	190	250	325	425	—	—	—	9,5

iTel STANDARD PREVIEW
 (standards.itel.ai)
 ISO 15:1981
<https://standards.itel.ai/catalog/standards/sist/d1836fe-567e-440f-ae6c-42a01a5e0c0/iso-15-1981>

Table 3 — Diameter series 9

Dimensions in millimetres

<i>d</i>	<i>D</i>	Dimension series										
		09	19	29	39	49	59	69	09	19-39	49-69	
		<i>B</i>							<i>r_s min</i>			
1	4	—	1,6	—	2,3	—	—	—	—	—	0,1	—
1,5	5	—	2	—	2,6	—	—	—	—	—	0,15	—
2	6	—	2,3	—	3	—	—	—	—	—	0,15	—
2,5	7	—	2,5	—	3,5	—	—	—	—	—	0,15	—
3	8	—	3	—	4	—	—	—	—	—	0,15	—
4	11	—	4	—	5	—	—	—	—	—	0,15	—
5	13	—	4	—	6	10	—	—	—	—	0,2	0,15
6	15	—	5	—	7	10	—	—	—	—	0,2	0,15
7	17	—	5	—	7	10	—	—	—	—	0,3	0,15
8	19	—	6	—	9	11	—	—	—	—	0,3	0,2
9	20	—	6	—	9	11	—	—	—	—	0,3	0,3
10	22	—	6	8	10	13	16	22	—	—	0,3	0,3
12	24	—	6	8	10	13	16	22	—	—	0,3	0,3
15	28	—	7	8,5	10	13	18	23	—	—	0,3	0,3
17	30	—	7	8,5	10	13	18	23	—	—	0,3	0,3
20	37	7	9	11	13	17	23	30	0,3	—	0,3	0,3
22	39	7	9	11	13	17	23	30	0,3	—	0,3	0,3
25	42	7	9	11	13	17	23	30	0,3	—	0,3	0,3
28	45	7	9	11	13	17	23	30	0,3	—	0,3	0,3
30	47	7	9	11	13	17	23	30	0,3	—	0,3	0,3
32	52	7	10	13	15	20	27	36	0,3	—	0,6	0,6
35	55	7	10	13	15	20	27	36	0,3	—	0,6	0,6
40	62	8	12	14	16	22	30	40	0,3	—	0,6	0,6
45	68	8	12	14	16	22	30	40	0,3	—	0,6	0,6
50	72	8	12	14	16	22	30	40	0,3	—	0,6	0,6
55	80	9	13	16	19	25	34	45	0,3	—	1	1
60	85	9	13	16	19	25	34	45	0,3	—	1	1
65	90	9	13	16	19	25	34	45	0,3	—	1	1
70	100	10	16	19	23	30	40	54	0,6	—	1	1
75	105	10	16	19	23	30	40	54	0,6	—	1	1
80	110	10	16	19	23	30	40	54	0,6	—	1	1
85	120	11	18	22	26	35	46	63	0,6	—	1,1	1,1
90	125	11	18	22	26	35	46	63	0,6	—	1,1	1,1
95	130	11	18	22	26	35	46	63	0,6	—	1,1	1,1
100	140	13	20	24	30	40	54	71	0,6	—	1,1	1,1
105	145	13	20	24	30	40	54	71	0,6	—	1,1	1,1
110	150	13	20	24	30	40	54	71	0,6	—	1,1	1,1
120	165	14	22	27	34	45	60	80	0,6	—	1,1	1,1
130	180	16	24	30	37	50	67	90	1	—	1,5	1,5
140	190	16	24	30	37	50	67	90	1	—	1,5	1,5
150	210	19	28	36	45	60	80	109	1	—	2	2
160	220	19	28	36	45	60	80	109	1	—	2	2
170	230	19	28	36	45	60	80	109	1	—	2	2
180	250	22	33	42	52	69	95	125	1,1	—	2	2

Table 3 (concluded)

Dimensions in millimetres

d	D	Dimension series								
		09	19	29	39	49	59	69	09	19-69
		B							r _s min	
190	260	22	33	42	52	69	95	125	1,1	2
200	280	25	38	48	60	80	109	145	1,5	2,1
220	300	25	38	48	60	80	109	145	1,5	2,1
240	320	25	38	48	60	80	109	145	1,5	2,1
260	360	31	46	60	75	100	136	180	2	2,1
280	380	31	46	60	75	100	136	180	2	2,1
300	420	37	56	72	90	118	160	218	2,1	3
320	440	37	56	72	90	118	160	218	2,1	3
340	460	37	56	72	90	118	160	218	2,1	3
360	480	37	56	72	90	118	160	218	2,1	3
380	520	44	65	82	106	140	190	250	3	4
400	540	44	65	82	106	140	190	250	3	4
420	560	44	65	82	106	140	190	250	3	4
440	600	50	74	95	118	160	218	290	4	4
460	620	50	74	95	118	160	218	290	4	4
480	650	54	78	100	128	170	230	308	4	5
500	670	54	78	100	128	170	230	308	4	5
530	710	57	82	106	136	180	243	325	4	5
560	750	60	85	112	140	190	258	345	5	5
600	800	63	90	118	150	200	272	355	5	5
630	850	71	100	128	165	218	300	400	5	6
670	900	73	103	136	170	230	308	412	5	6
710	950	78	106	140	180	243	325	438	5	6
750	1 000	80	112	145	185	250	335	450	6	6
800	1 060	82	115	150	195	258	355	462	6	6
850	1 120	85	118	155	200	272	365	488	6	6
900	1 180	88	122	165	206	280	375	500	6	6
950	1 250	95	132	175	224	300	400	545	6	7,5
1 000	1 320	103	140	185	236	315	438	580	6	7,5
1 060	1 400	109	150	195	250	335	462	615	7,5	7,5
1 120	1 460	109	150	195	250	335	462	615	7,5	7,5
1 180	1 540	115	160	206	272	355	488	650	7,5	7,5
1 250	1 630	122	170	218	280	375	515	690	7,5	7,5
1 320	1 720	128	175	230	300	400	545	710	7,5	7,5
1 400	1 820	—	185	243	315	425	—	—	—	9,5
1 500	1 950	—	195	258	335	450	—	—	—	9,5
1 600	2 060	—	200	265	345	462	—	—	—	9,5
1 700	2 180	—	212	280	355	475	—	—	—	9,5
1 800	2 300	—	218	290	375	500	—	—	—	12
1 900	2 430	—	230	308	400	530	—	—	—	12

Table 4 — Diameter series 0

Dimensions in millimetres

d	D	Dimension series									
		00	10	20	30	40	50	60	00	10-60	
		B							r _s min		
1,5	6	—	2,5	—	3	—	—	—	—	—	0,15
2	7	—	2,8	—	3,5	—	—	—	—	—	0,15
2,5	8	—	2,8	—	4	—	—	—	—	—	0,15
3	9	—	3	—	5	—	—	—	—	—	0,15
4	12	—	4	—	6	—	—	—	—	—	0,2
5	14	—	5	—	7	—	—	—	—	—	0,2
6	17	—	6	—	9	—	—	—	—	—	0,3
7	19	—	6	8	10	—	—	—	—	—	0,3
8	22	—	7	9	11	14	19	25	—	—	0,3
9	24	—	7	10	12	15	20	27	—	—	0,3
10	26	—	8	10	12	16	21	29	—	—	0,3
12	28	7	8	10	12	16	21	29	0,3	—	0,3
15	32	8	9	11	13	17	23	30	0,3	—	0,3
17	35	8	10	12	14	18	24	32	0,3	—	0,3
20	42	8	12	14	16	22	30	40	0,3	—	0,6
22	44	8	12	14	16	22	30	40	0,3	—	0,6
25	47	8	12	14	16	22	30	40	0,3	—	0,6
28	52	8	12	15	18	24	32	43	0,3	—	0,6
30	55	9	13	16	19	25	34	45	0,3	—	1
32	58	9	13	16	20	26	35	47	0,3	—	1
35	62	9	14	17	20	27	36	48	0,3	—	1
40	68	9	15	18	21	28	38	50	0,3	—	1
45	75	10	16	19	23	30	40	54	0,6	—	1
50	80	10	16	19	23	30	40	54	0,6	—	1
55	90	11	18	22	26	35	46	63	0,6	—	1,1
60	95	11	18	22	26	35	46	63	0,6	—	1,1
65	100	11	18	22	26	35	46	63	0,6	—	1,1
70	110	13	20	24	30	40	54	71	0,6	—	1,1
75	115	13	20	24	30	40	54	71	0,6	—	1,1
80	125	14	22	27	34	45	60	80	0,6	—	1,1
85	130	14	22	27	34	45	60	80	0,6	—	1,1
90	140	16	24	30	37	50	67	90	1	—	1,5
95	145	16	24	30	37	50	67	90	1	—	1,5
100	150	16	24	30	37	50	67	90	1	—	1,5
105	160	18	26	33	41	56	75	100	1	—	2
110	170	19	28	36	45	60	80	109	1	—	2
120	180	19	28	36	46	60	80	109	1	—	2
130	200	22	33	42	52	69	95	125	1,1	—	2
140	210	22	33	42	53	69	95	125	1,1	—	2
150	225	24	35	45	56	75	100	136	1,1	—	2,1
160	240	25	38	48	60	80	109	145	1,5	—	2,1
170	260	28	42	54	67	90	122	160	1,5	—	2,1
180	280	31	46	60	74	100	136	180	2	—	2,1

Table 4 (concluded)

Dimensions in millimetres

d	D	Dimension series								
		00	10	20	30	40	50	60	00	10-60
		B							r _s min	
190	290	31	46	60	75	100	136	180	2	2,1
200	310	34	51	66	82	109	150	200	2	2,1
220	340	37	56	72	90	118	160	218	2,1	3
240	360	37	56	72	92	118	160	218	2,1	3
260	400	44	65	82	104	140	190	250	3	4
280	420	44	65	82	106	140	190	250	3	4
300	460	50	74	95	118	160	218	290	4	4
320	480	50	74	95	121	160	218	290	4	4
340	520	57	82	106	133	180	243	325	4	5
360	540	57	82	106	134	180	243	325	4	5
380	560	57	82	106	135	180	243	325	4	5
400	600	63	90	118	148	200	272	355	5	5
420	620	63	90	118	150	200	272	355	5	5
440	650	67	94	122	157	212	280	375	5	6
460	680	71	100	128	163	218	300	400	5	6
480	700	71	100	128	165	218	300	400	5	6
500	720	71	100	128	167	218	300	400	5	6
530	780	80	112	145	185	250	335	450	6	6
560	820	82	115	150	195	258	355	462	6	6
600	870	85	118	155	200	272	365	488	6	6
630	920	92	128	170	212	290	388	515	6	7,5
670	980	100	136	180	230	308	425	560	6	7,5
710	1 030	103	140	185	236	315	438	580	6	7,5
750	1 090	109	150	195	250	335	462	615	7,5	7,5
800	1 150	112	155	200	258	345	475	630	7,5	7,5
850	1 220	118	165	212	272	365	500	670	7,5	7,5
900	1 280	122	170	218	280	375	515	690	7,5	7,5
950	1 360	132	180	236	300	412	560	730	7,5	7,5
1 000	1 420	136	185	243	308	412	560	750	7,5	7,5
1 060	1 500	140	195	250	325	438	600	800	9,5	9,5
1 120	1 580	145	200	265	345	462	615	825	9,5	9,5
1 180	1 660	155	212	272	355	475	650	875	9,5	9,5
1 250	1 750	—	218	290	375	500	—	—	—	9,5
1 320	1 850	—	230	300	400	530	—	—	—	12
1 400	1 950	—	243	315	412	545	—	—	—	12
1 500	2 120	—	272	355	462	615	—	—	—	12
1 600	2 240	—	280	365	475	630	—	—	—	12
1 700	2 360	—	290	375	500	650	—	—	—	15
1 800	2 500	—	308	400	530	690	—	—	—	15

Table 5 — Diameter series 1

Dimensions in millimetres

<i>d</i>	<i>D</i>	Dimension series						
		01	11	21	31	41	01	11-41
		<i>B</i>					<i>r_s min</i>	
90	150	—	—	—	—	60	—	2
95	160	—	—	—	—	65	—	2
100	165	21	30	39	52	65	1,1	2
105	175	22	33	42	56	69	1,1	2
110	180	22	33	42	56	69	1,1	2
120	200	25	38	48	62	80	1,5	2
130	210	25	38	48	64	80	1,5	2
140	225	27	40	50	68	85	1,5	2,1
150	250	31	46	60	80	100	2	2,1
160	270	34	51	66	86	109	2	2,1
170	280	34	51	66	88	109	2	2,1
180	300	37	56	72	96	118	2,1	3
190	320	42	60	78	104	128	3	3
200	340	44	65	82	112	140	3	3
220	370	48	69	88	120	150	3	4
240	400	50	74	95	128	160	4	4
260	440	57	82	106	144	180	4	4
280	460	57	82	106	146	180	4	5
300	500	63	90	118	160	200	5	5
320	540	71	100	128	176	218	5	5
340	580	78	106	140	190	243	5	5
360	600	78	106	140	192	243	5	5
380	620	78	106	140	194	243	5	5
400	650	80	112	145	200	250	6	6
420	700	88	122	165	224	280	6	6
440	720	88	122	165	226	280	6	6
460	760	95	132	175	240	300	6	7,5
480	790	100	136	180	248	308	6	7,5
500	830	106	145	190	264	325	7,5	7,5
530	870	109	150	195	272	335	7,5	7,5
560	920	115	160	206	280	355	7,5	7,5
600	980	122	170	218	300	375	7,5	7,5
630	1 030	128	175	230	315	400	7,5	7,5
670	1 090	136	185	243	336	412	7,5	7,5
710	1 150	140	195	250	345	438	9,5	9,5
750	1 220	150	206	272	365	475	9,5	9,5
800	1 280	155	212	272	375	475	9,5	9,5
850	1 360	165	224	290	400	500	12	12
900	1 420	165	230	300	412	515	12	12
950	1 500	175	243	315	438	545	12	12
1 000	1 580	185	258	335	462	580	12	12
1 060	1 660	190	265	345	475	600	12	15
1 120	1 750	—	280	365	475	630	—	15
1 180	1 850	—	290	388	500	670	—	15
1 250	1 950	—	308	400	530	710	—	15
1 320	2 060	—	325	425	560	750	—	15
1 400	2 180	—	345	450	580	775	—	19
1 500	2 300	—	355	462	600	800	—	19