



SLOVENSKI STANDARD
SIST EN 12234:2013

01-november-2013

Nadomešča:
SIST EN 12234:2003

Podloge za športne dejavnosti - Ugotavljanje obnašanja žoge pri kotaljenju

Surfaces for sports areas - Determination of ball roll behaviour

Sportböden - Bestimmung des Ballrollverhaltens

Sols sportifs - Détermination du comportement de la balle en roulement

iTeh STANDARD PREVIEW
(standards.iteh.ai)

Ta slovenski standard je istoveten z: ~~SIST EN 12234:2013~~ EN 12234:2013

<https://standards.iteh.ai/catalog/standards/sist/d377178d-f9f-445c-aa69-e189ab60ca4/sist-en-12234-2013>

ICS:

97.220.10 Športni objekti Sports facilities

SIST EN 12234:2013 **en,fr,de**

iTeh STANDARD PREVIEW
(standards.iteh.ai)

SIST EN 12234:2013

<https://standards.iteh.ai/catalog/standards/sist/d377178d-ff9f-445c-aa69-c1f89ab60ca4/sist-en-12234-2013>

EUROPEAN STANDARD

EN 12234

NORME EUROPÉENNE

EUROPÄISCHE NORM

September 2013

ICS 97.220.10

Supersedes EN 12234:2002

English Version

Surfaces for sports areas - Determination of ball roll behaviourSols sportifs - Détermination du comportement de la balle
en roulement

Sportböden - Bestimmung des Ballrollverhaltens

This European Standard was approved by CEN on 11 July 2013.

CEN members are bound to comply with the CEN/CENELEC Internal Regulations which stipulate the conditions for giving this European Standard the status of a national standard without any alteration. Up-to-date lists and bibliographical references concerning such national standards may be obtained on application to the CEN-CENELEC Management Centre or to any CEN member.

This European Standard exists in three official versions (English, French, German). A version in any other language made by translation under the responsibility of a CEN member into its own language and notified to the CEN-CENELEC Management Centre has the same status as the official versions.

CEN members are the national standards bodies of Austria, Belgium, Bulgaria, Croatia, Cyprus, Czech Republic, Denmark, Estonia, Finland, Former Yugoslav Republic of Macedonia, France, Germany, Greece, Hungary, Iceland, Ireland, Italy, Latvia, Lithuania, Luxembourg, Malta, Netherlands, Norway, Poland, Portugal, Romania, Slovakia, Slovenia, Spain, Sweden, Switzerland, Turkey and United Kingdom.

[SIST EN 12234:2013](https://standards.iteh.ai/catalog/standards/sist/d377178d-f9f-445c-aa69-c1f89ab60ca4/sist-en-12234-2013)<https://standards.iteh.ai/catalog/standards/sist/d377178d-f9f-445c-aa69-c1f89ab60ca4/sist-en-12234-2013>EUROPEAN COMMITTEE FOR STANDARDIZATION
COMITÉ EUROPÉEN DE NORMALISATION
EUROPÄISCHES KOMITEE FÜR NORMUNG**CEN-CENELEC Management Centre: Avenue Marnix 17, B-1000 Brussels**

Contents

	Page
Foreword.....	3
1 Scope.....	4
2 Normative references.....	4
3 Principle.....	4
4 Apparatus	4
5 Preparation of the test specimen	5
6 Conditioning.....	6
7 Procedure	6
8 Calculation and expression of results	7
9 Test report	7

iTeh STANDARD PREVIEW (standards.iteh.ai)

[SIST EN 12234:2013](https://standards.iteh.ai/catalog/standards/sist/d377178d-f9f-445c-aa69-c1f89ab60ca4/sist-en-12234-2013)

<https://standards.iteh.ai/catalog/standards/sist/d377178d-f9f-445c-aa69-c1f89ab60ca4/sist-en-12234-2013>

Foreword

This document (EN 12234:2013) has been prepared by Technical Committee CEN/TC 217 “Surfaces for sports areas”, the secretariat of which is held by AFNOR.

This European Standard shall be given the status of a national standard, either by publication of an identical text or by endorsement, at the latest by March 2014, and conflicting national standards shall be withdrawn at the latest by March 2014.

Attention is drawn to the possibility that some of the elements of this document may be the subject of patent rights. CEN [and/or CENELEC] shall not be held responsible for identifying any or all such patent rights.

This document supersedes EN 12234:2002.

Compared with EN 12234:2002, the text has been clarified and editorial errors have been corrected.

According to the CEN-CENELEC Internal Regulations, the national standards organizations of the following countries are bound to implement this European Standard: Austria, Belgium, Bulgaria, Croatia, Cyprus, Czech Republic, Denmark, Estonia, Finland, Former Yugoslav Republic of Macedonia, France, Germany, Greece, Hungary, Iceland, Ireland, Italy, Latvia, Lithuania, Luxembourg, Malta, Netherlands, Norway, Poland, Portugal, Romania, Slovakia, Slovenia, Spain, Sweden, Switzerland, Turkey and the United Kingdom.

iTeh STANDARD PREVIEW (standards.iteh.ai)

[SIST EN 12234:2013](https://standards.iteh.ai/catalog/standards/sist/d377178d-f9f-445c-aa69-c1f89ab60ca4/sist-en-12234-2013)

<https://standards.iteh.ai/catalog/standards/sist/d377178d-f9f-445c-aa69-c1f89ab60ca4/sist-en-12234-2013>

EN 12234:2013 (E)

1 Scope

This European Standard specifies a method for determining the rolling behaviour of a ball on a sports surface.

2 Normative references

The following documents, in whole or in part, are normatively referenced in this document and are indispensable for its application. For dated references, only the edition cited applies. For undated references, the latest edition of the referenced document (including any amendments) applies.

EN 12229, *Surfaces for sports areas — Procedure for the preparation of synthetic turf and needle-punch test pieces*

EN 12235, *Surfaces for sports areas — Determination of vertical ball behaviour*

3 Principle

A ball is rolled down a ramp, from a specified height, onto a test surface and either the distance the ball rolls or the velocity change of the ball on the surface is measured.

4 Apparatus

4.1 Ball, conforming to the regulations of the governing body of the relevant sport and as described in EN 12235.

4.2 Ball roll ramp, comprising two smooth parallel bars mounted at an angle of $(45 \pm 2)^\circ$ on a rigid frame, and having dimensions in accordance with Figures 1 and 2.

At their lower end, the bars curve to become parallel with the ground.

NOTE The spacing between the parallel bars depends on the diameter of the ball used in the test.

Dimensions in millimetres

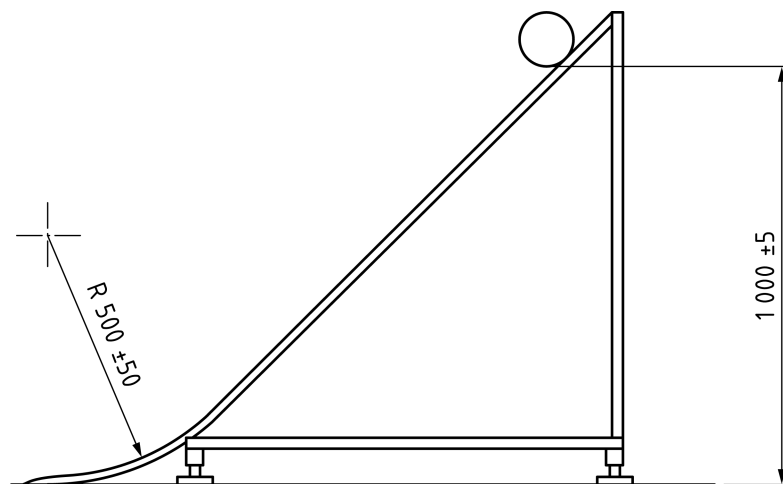
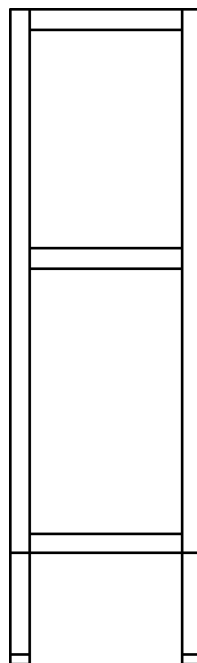

Figure 1 — Side view of ball roll ramp

Dimensions in millimetres



iTeh STANDARD PREVIEW

Key: (guidance width for each ball type) (standards.iteh.ai)

$l = 100 \pm 10$ mm association Football

$l = 45 \pm 5$ mm hockey

SIST EN 12234:2013

<https://standards.iteh.ai/catalog/standards/sist/d377178d-fb9f-445c-aa69-1f72e60ca1e2/en-12234-2013>

Figure 2 — Plan of ball roll ramps

4.3 Bubble level, suitable for measuring vertical and horizontal alignment.

4.4 Alignment device, suitable for setting the ball roll ramp vertically on a level surface.

4.5 Tape measure, for determination of all rolling distances.

4.6 Set of optically triggered timing gates, accurate to 0,1 m/s, to measure the speed of the ball at two points in its travel, for determination of velocity change, the first timing gate positioned at least 1 m from the end of the ramp to eliminate any top spin generated by the ramp.

NOTE Optically triggered timing gates are only required for velocity change determination (see 7.1).

4.7 Means of measuring wind speed, accurate to within 0,1 km/h.

5 Preparation of the test specimen

The test shall be carried out on *in situ* indoor or outdoor sport surfaces, or on a specimen assembled for test purposes in accordance with EN 12229.

If a test specimen is to be used, prepare this from a representative sample of the sports surface.

Assemble the surface in accordance with the method recommended by the manufacturer.

EN 12234:2013 (E)

For determination of ball rolling distance, prepare the test specimen of minimum width 1,0 m and of sufficient length to ensure that the ball comes to rest not less than 100 mm from the side and 250 mm from the far end of the test piece.

For determination of velocity change, prepare the test specimen of minimum width 1 m and minimum length 2 m.

NOTE Tests for field hockey may require a wider test piece to allow ball roll deviation to be measured.

As the infill material will influence the results, it is required that each system and infill type is tested.

6 Conditioning

Condition the specimens for a minimum of 3 h at the test temperature. Unless otherwise specified, condition and test the specimen at a temperature of (23 ± 2) °C.

For tests on site, condition the ball for a minimum of 1 h at the prevailing ambient temperature.

7 Procedure**7.1 Ball rolling procedure**

For tests being conducted on site, determine the wind speed at the test site (4.7). If the wind speed at the test site exceeds 3,2 km/h, do not proceed with the determination unless a shielding system can be used to mitigate the influence of the wind whilst not interfering with the test method.

Set the ball roll ramp (4.2) with the aid of the bubble level (4.3) and alignment device (4.4) vertically upon the test surface or specimen, curvature and distance between the parallel bars for the type of ball, as given in Figures 1 and 2.

Place the ramp at a height so that the vertical distance between the base of the ball and the point where it first makes contact with the surface is $(1\ 000 \pm 15)$ mm. Release the ball and allow it to roll until it comes to rest. Measure the distance from the point at which the ball first touched the surface to the point below the centre of the ball at which it is resting on the surface.

In the laboratory, if the ball travels within 100 mm of an edge of the test surface or specimen, disregard the result and repeat the procedure.

Repeat the procedure to obtain five readings of ball roll distance. Move the ramp slightly between each procedure to avoid tracking.

In the laboratory the test should be conducted in both directions; for field testing the test should be conducted in four directions (at 90 degree intervals).

7.2 Velocity change

For tests being conducted on site, determine the wind speed at the test site (4.7). If the wind speed at the test site exceeds 3,2 km/h, do not proceed with the determination.

Place the timing gates (4.6) on the test surface or specimen, so that the ball is able to pass between them, with a distance between the gates of $(1\ 000 \pm 5)$ mm.

Place the ball on the ramp at a suitable height and release the ball so that it rolls through the two timing gates in turn. Record the time taken for the ball to pass through each gate, the velocity at the first gate being initial velocity and the velocity at the second gate final velocity.

Repeat the test to obtain at least five readings of initial and final velocity, each time varying slightly the height of the ramp from which the ball is released to vary the initial velocity within a range of 2,5 m/s. Move the ramp slightly between each procedure to avoid tracking.