



SLOVENSKI STANDARD

SIST EN 1870-19:2014

01-marec-2014

Nadomešča:

SIST EN 1870-1:2007+A1:2009

Varnost lesnoobdelovalnih strojev - Krožne žage - 19. del: Krožne žage (z dodatno mizo ali brez nje) in krožne žage, ki se uporabljajo na gradbišču

Safety of woodworking machines - Circular sawing machines - Part 19: Circular saw benches (with and without sliding table) and building site saws

Sicherheit von Holzbearbeitungsmaschinen - Kreissägemaschinen - Teil 19: Tischkreissägemaschinen (mit und ohne Schiebetisch) und Baustellenkreissägemaschinen

SIST EN 1870-19:2014

Sécurité des machines pour le travail du bois - Machines à scies circulaires - Partie 19: Scies circulaires à table de menuisier (avec et sans table mobile) et scies de chanter

Ta slovenski standard je istoveten z: EN 1870-19:2013

ICS:

25.080.60	Strojne žage	Sawing machines
79.120.10	Lesnoobdelovalni stroji	Woodworking machines
91.220	Gradbena oprema	Construction equipment

SIST EN 1870-19:2014

en,fr,de

iTeh STANDARD PREVIEW
(standards.iteh.ai)

[SIST EN 1870-19:2014](#)

<https://standards.iteh.ai/catalog/standards/sist/59ab0695-8cca-44d3-af2a-8e0910e51643/sist-en-1870-19-2014>

EUROPEAN STANDARD

EN 1870-19

NORME EUROPÉENNE

EUROPÄISCHE NORM

November 2013

ICS 79.120.10

Supersedes EN 1870-1:2007+A1:2009

English Version

Safety of woodworking machines - Circular sawing machines - Part 19: Circular saw benches (with and without sliding table) and building site saws

Sécurité des machines pour le travail du bois - Machines à scies circulaires - Partie 19: Scies circulaires à table de menuisier (avec et sans table mobile) et scies de chantier

Sicherheit von Holzbearbeitungsmaschinen - Kreissägemaschinen - Teil 19: Tischkreissägemaschinen (mit und ohne Schiebetisch) und Baustellenkreissägemaschinen

This European Standard was approved by CEN on 7 September 2013.

CEN members are bound to comply with the CEN/CENELEC Internal Regulations which stipulate the conditions for giving this European Standard the status of a national standard without any alteration. Up-to-date lists and bibliographical references concerning such national standards may be obtained on application to the CEN-CENELEC Management Centre or to any CEN member.

This European Standard exists in three official versions (English, French, German). A version in any other language made by translation under the responsibility of a CEN member into its own language and notified to the CEN-CENELEC Management Centre has the same status as the official versions.

CEN members are the national standards bodies of Austria, Belgium, Bulgaria, Croatia, Cyprus, Czech Republic, Denmark, Estonia, Finland, Former Yugoslav Republic of Macedonia, France, Germany, Greece, Hungary, Iceland, Ireland, Italy, Latvia, Lithuania, Luxembourg, Malta, Netherlands, Norway, Poland, Portugal, Romania, Slovakia, Slovenia, Spain, Sweden, Switzerland, Turkey and United Kingdom.



EUROPEAN COMMITTEE FOR STANDARDIZATION
COMITÉ EUROPÉEN DE NORMALISATION
EUROPÄISCHES KOMITEE FÜR NORMUNG

CEN-CENELEC Management Centre: Avenue Marnix 17, B-1000 Brussels

Contents

Page

Foreword.....	5
Introduction	7
1 Scope	8
2 Normative references	8
3 Terms and definitions	11
3.1 General.....	11
3.2 Definitions	11
4 List of significant hazards	17
5 Safety requirements and/or measures	23
5.1 General.....	23
5.2 Controls	23
5.2.1 Safety and reliability of control systems.....	23
5.2.2 Position of controls	24
5.2.3 Starting	25
5.2.4 Normal stopping	26
5.2.5 Emergency stop.....	27
5.2.6 Speed control for circular saw benches	27
5.2.7 Power operated adjustment of the saw blade(s) and/or fence(s) on circular saw benches	28
5.2.8 Interlocking of guards, movements and functions	29
5.2.9 Failure of the power supply	29
5.2.10 Failure of the control circuits	29
5.3 Protection against mechanical hazards	30
5.3.1 Stability	30
5.3.2 Hazard of break up during operation.....	30
5.3.3 Tool holder and tool design.....	31
5.3.4 Braking.....	32
5.3.5 Devices to minimize the possibility or the effect of kickback.....	33
5.3.6 Workpiece supports and guides	40
5.3.7 Prevention of access to moving parts.....	44
5.3.8 Powered workpiece clamping	57
5.3.9 Safety appliances.....	57
5.4 Protection against non-mechanical hazards	61
5.4.1 Fire	61
5.4.2 Noise	61

5.4.3	Emission of chips and dust.....	63
5.4.4	Electricity.....	64
5.4.5	Ergonomics and handling	65
5.4.6	Pneumatics	66
5.4.7	Electromagnetic compatibility	66
5.4.8	Laser	66
5.4.9	Static electricity	66
5.4.10	Errors of fitting	66
5.4.11	Supply disconnection (Isolation).....	67
5.4.12	Maintenance.....	67
6	Information for use.....	67
6.1	General	67
6.2	Marking.....	68
6.2.1	Marking of the machine	68
6.2.2	Marking of riving knives	69
6.3	Instruction handbook.....	69
Annex A (normative)	Stability test	74
Annex B (normative)	Test for rigidity of building site saws.....	75
Annex C (normative)	Saw spindle dimensional tolerances.....	76
Annex D (normative)	Riving knife mounting strength test.....	77
Annex E (normative)	Riving knife lateral stability test.....	78
Annex F (normative)	Minimum dimensions of the machine table, extension table and insert	79
Annex G (normative)	Saw blade guard stability test.....	81
G.1	General	81
G.2	Separately from riving knife mounted saw blade guards	81
G.2.1	Saw blade guards with lead-in	81
G.2.2	Saw blade guards with in-feed rollers.....	82
G.3	Riving knife mounted saw blade guards.....	83
Annex H (normative)	Impact test method for guards.....	85
H.1	General	85
H.2	Test method	85
H.2.1	Preliminary remarks	85
H.2.2	Testing equipment.....	85
H.2.3	Projectile for guards.....	85
H.2.4	Sampling.....	85
H.2.5	Test procedure.....	85
H.3	Results.....	86
H.4	Assessment	86
H.5	Test report.....	86
H.6	Test equipment for impact test	86
Annex I (normative)	Braking tests	88
I.1	Conditions for all tests.....	88
I.2	Tests	88
I.2.1	Un-braked run-down time	88
I.2.2	Braked run-down time.....	88

EN 1870-19:2013 (E)

Annex ZA (informative) Relationship between this European Standard and the Essential Requirements of EU Directive 2006/42/EC	89
Bibliography	92

**iTeh STANDARD PREVIEW
(standards.iteh.ai)**

SIST EN 1870-19:2014

<https://standards.iteh.ai/catalog/standards/sist/59ab0695-8cca-44d3-af2a-8e0910e51643/sist-en-1870-19-2014>

Foreword

This document (EN 1870-19:2013) has been prepared by Technical Committee CEN/TC 142 "Woodworking machines - Safety", the secretariat of which is held by UNI.

This European Standard shall be given the status of a national standard, either by publication of an identical text or by endorsement, at the latest by May 2014, and conflicting national standards shall be withdrawn at the latest by May 2014.

Attention is drawn to the possibility that some of the elements of this document may be the subject of patent rights. CEN [and/or CENELEC] shall not be held responsible for identifying any or all such patent rights.

This document together with EN 1870-18 supersedes EN 1870-1:2007+A1:2009.

The major technical changes from the previous edition are the following:

- a) the exclusion of saw blade guard mounted on wall, ceiling or floor;
- b) introduction of PL;
- c) inclusion of a stability test for displaceable machines;
- d) more precise requirements for braking function;
- e) more precise requirement on chips and dust extraction connections;
- f) extension of usable safety appliances;
- g) more precise requirements to prevent crushing and shearing hazards.

This document has been prepared under a mandate given to CEN by the European Commission and the European Free Trade Association, and supports essential requirements of the Machinery Directive.

For relationship with EU Directive(s), see informative Annex ZA, which is an integral part of this document.

EN 1870, *Safety of woodworking machines — Circular sawing machines* consists of the following parts:

- *Part 3: Down cutting cross-cut saws and dual purpose down cutting cross-cut saws/circular saw benches*
- *Part 4: Multi-blade rip sawing machines with manual loading and/or unloading*
- *Part 5: Circular saw benches/up-cutting cross-cut sawing machines*
- *Part 6: Circular sawing machines for firewood and dual purpose circular sawing machines for firewood/circular saw benches, with manual loading and/or unloading*
- *Part 7: Single blade log sawing machines with integrated feed table and manual loading and/or unloading*
- *Part 8: Single blade edging circular rip sawing machines with power driven saw unit and manual loading and/or unloading*
- *Part 9: Double blade circular sawing machines for cross-cutting with integrated feed and with manual loading and/or unloading*

EN 1870-19:2013 (E)

- *Part 10: Single blade automatic and semi-automatic up-cutting cross-cut sawing machines*
- *Part 11: Semi-automatic and automatic horizontal cross-cut sawing machines with one saw unit (radial arm saws)*
- *Part 12: Pendulum cross-cut sawing machines*
- *Part 13: Horizontal beam panel sawing machines*
- *Part 14: Vertical panel sawing machines*
- *Part 15: Multi-blade cross-cut sawing machines with integrated feed of the workpiece and manual loading and/or unloading*
- *Part 16: Double mitre sawing machines for V-cutting*
- *Part 17: Manual horizontal cutting cross-cut sawing machines with one saw unit (manual radial arm saws)*
- *Part 18: Dimension saws*
- *Part 19: Circular saw benches (with and without sliding table) and building site saws*

Organizations contributing to the preparation of this European Standard include European Committee of Woodworking Machinery Manufacturers Association "EUMABOIS".

The European Standards produced by CEN/TC 142 are particular to woodworking machines and complement the relevant A and B Standards on the subject of general safety (see Introduction of EN ISO 12100:2010 for a description of A, B and C standards).

According to the CEN-CENELEC Internal Regulations, the national standards organizations of the following countries are bound to implement this European Standard: Austria, Belgium, Bulgaria, Croatia, Cyprus, Czech Republic, Denmark, Estonia, Finland, Former Yugoslav Republic of Macedonia, France, Germany, Greece, Hungary, Iceland, Ireland, Italy, Latvia, Lithuania, Luxembourg, Malta, Netherlands, Norway, Poland, Portugal, Romania, Slovakia, Slovenia, Spain, Sweden, Switzerland, Turkey and the United Kingdom.

Introduction

This document has been prepared to be a harmonized standard to provide one means of conforming to the essential safety requirements of the Machinery Directive and associated EFTA regulations. This document is a type "C" standard as defined in EN ISO 12100:2010.

The machinery concerned and the extent to which hazards, hazardous situations and events are covered are indicated in the scope of this document.

When provisions of this type C standard are different from those which are stated in type A or B standards, the provisions of this type C standard take precedence over the provisions of other standards, for machines that have been designed and built according to the provisions of this type C standard.

The requirements of this document are directed to manufacturers and their authorized representatives of circular saw benches (with and without sliding table) and building site saws. They are also useful for designers.

This document also includes provisions and examples of information to be provided by the manufacturer to the user.

Common requirements for tooling are given in EN 847-1:2013.

ITEH STANDARD PREVIEW
(standards.iteh.ai)

SIST EN 1870-19:2014

<https://standards.iteh.ai/catalog/standards/sist/59ab0695-8cca-44d3-af2a-8e0910e51643/sist-en-1870-19-2014>

EN 1870-19:2013 (E)**1 Scope**

This European Standard deals with all significant hazards, hazardous situations and events as listed in Clause 4 which are relevant to stationary and displaceable circular saw benches (with or without sliding table and/or demountable power feed unit) and building site saws, hereinafter referred to as “machines”, designed to cut solid wood, chipboard, fibreboard, plywood and also these materials, if they are covered with plastic edging and/or plastic/light alloy laminates, when they are used as intended and under the conditions foreseen by the manufacturer including reasonably foreseeable misuse.

Machines which are designed to cut wood-based material may also be used for cutting hardened plastic materials with similar physical characteristics as wood.

NOTE 1 For the definition of stationary and displaceable machine see 3.2.9 and 3.2.10.

NOTE 2 Circular saw benches are used for ripping, cross cutting, dimensioning and grooving. Building site saws are used for ripping, cross cutting and dimensioning.

The requirements of this document apply also to machines designed for grooving with a width not exceeding 20 mm in one pass by using a milling tool.

This document does not apply to:

- a) machines set up on a bench or a table similar to a bench, which are intended to carry out work in a stationary position, capable of being lifted by one person by hand. The bench can also be an integrated part of the machine if it consists of hinged legs which can be extended down;
- b) hand held woodworking machines (including any adaptation permitting their use in a different mode, i.e. bench mounting).

NOTE 3 Transportable motor-operated electric tools are covered by the requirements of EN 61029-1:2009 together with EN 61029-2-1:2012; a hand-held motor-operated electric tool and a saw bench to form an integrated whole are covered by EN 60745-1:2009 together with EN 60745-2-5: 2010.

For the purpose of this document, building site saws having a tiltable spindle are considered to be circular saw benches.

This document is not applicable to circular saw benches (with and without sliding table) and building site saws which are manufactured before the date of its publication as EN.

NOTE 4 Machines covered by this document are listed under 1.1 of Annex IV of the Machinery Directive.

2 Normative references

The following documents, in whole or in part, are normatively referenced in this document and are indispensable for its application. For dated references, only the edition cited applies. For undated references, the latest edition of the referenced document (including any amendments) applies.

EN 614-1:2006+A1:2009, *Safety of machinery — Ergonomic design principles — Part 1: Terminology and general principles*

EN 847-1:2013, *Tools for woodworking — Safety requirements — Part 1: Milling tools, circular saw blades*

EN 894-1:1997+A1:2008, *Safety of machinery — Ergonomics requirements for the design of displays and control actuators — Part 1: General principles for human interactions with displays and control actuators*

EN 894-2:1997+A1:2008, *Safety of machinery — Ergonomics requirements for the design of displays and control actuators — Part 2: Displays*

EN 894-3:2000+A1:2008, *Safety of machinery — Ergonomics requirements for the design of displays and control actuators — Part 3: Control actuators*

EN 1005-1:2001+A1:2008, *Safety of machinery — Human physical performance — Part 1: Terms and definitions*

EN 1005-2:2003+A1:2008, *Safety of machinery — Human physical performance — Part 2: Manual handling of machinery and component parts of machinery*

EN 1005-3:2002+A1:2008, *Safety of machinery — Human physical performance — Part 3: Recommended force limits for machinery operation*

EN 1005-4:2005+A1:2008, *Safety of machinery — Human physical performance — Part 4: Evaluation of working postures and movements in relation to machinery*

EN 1037:1995+A1:2008, *Safety of machinery — Prevention of unexpected start-up*

EN 1088:1995+A2:2008, *Safety of machinery — Interlocking devices associated with guards — Principles for design and selection*

EN 50370-1:2005, *Electromagnetic compatibility (EMC) — Product family standard for machine tools — Part 1: Emission*

EN 50370-2:2003, *Electromagnetic compatibility (EMC) — Product family standard for machine tools — Part 2: Immunity*

EN 50525-2-21:2011, *Electric cables — Low voltage energy cables of rated voltages up to and including 450/750 V (U_o/U) — Part 2-21: Cables for general applications — Flexible cables with crosslinked elastomeric insulation*

EN 60204-1:2006, *Safety of machinery — Electrical equipment of machines — Part 1: General requirements (IEC 60204-1:2005, modified)*

EN 60439-1:1999¹⁾, *Low voltage switchgear and controlgear assemblies — Part 1: Type-tested and partially type-tested assemblies (IEC 60439-1:1999)*

EN 60529:1991²⁾, *Degrees of protection provided by enclosures (IP Code) (IEC 60529:1989)*

EN 60825-1:2007, *Safety of laser products — Part 1: Equipment classification, requirements and user's guide (IEC 60825-1:2007)*

EN 61310-1:2008, *Safety of machinery — Indication, marking and actuation — Part 1: Requirements for visual, acoustic and tactile signals (IEC 61310-1:2007)*

EN 61800-5-2:2007, *Adjustable speed electrical power drive systems — Part 5-2: Safety requirements — Functional (IEC 61800-5-2:2007)*

EN ISO 3743-1:2010, *Acoustics — Determination of sound power levels and sound energy levels of noise sources using sound pressure — Engineering methods for small movable sources in reverberant fields — Part 1: Comparison method for a hard-walled test room (ISO 3743-1:2010)*

EN ISO 3743-2:2009, *Acoustics — Determination of sound power levels of noise sources using sound pressure — Engineering methods for small, moveable sources in reverberant fields — Part 2: Methods for special reverberation test rooms (ISO 3743-2:1994)*

1) EN 60439-1:1999 is impacted by EN 60439-1:1999/A1:2004.

2) EN 60529:1991 is impacted by EN 60529:1991/A1:2000.

EN 1870-19:2013 (E)

EN ISO 3744:2010, *Acoustics — Determination of sound power levels and sound energy levels of noise sources using sound pressure — Engineering methods for an essentially free field over a reflecting plane (ISO 3744:2010)*

EN ISO 3745:2012, *Acoustics — Determination of sound power levels and sound energy levels of noise sources using sound pressure — Precision methods for anechoic rooms and hemi-anechoic rooms (ISO 3745:2012)*

EN ISO 3746:2010, *Acoustics — Determination of sound power levels and sound energy levels of noise sources using sound pressure — Survey method using an enveloping measurement surface over a reflecting plane (ISO 3746:2010)*

EN ISO 4413:2010, *Hydraulic fluid power — General rules and safety requirements for systems and their components (ISO 4413:2010)*

EN ISO 4414:2010, *Pneumatic fluid power — General rules and safety requirements for systems and their components (ISO 4414:2010)*

EN ISO 4871:2009, *Acoustics — Declaration and verification of noise emission values of machinery and equipment (ISO 4871:1996)*

EN ISO 9614-1:2009, *Acoustics — Determination of sound power levels of noise sources using sound intensity — Part 1: Measurement at discrete points (ISO 9614-1:1993)*

EN ISO 11202:2010, *Acoustics — Noise emitted by machinery and equipment — Determination of emission sound pressure levels at a work station and at other specified positions applying approximate environmental corrections (ISO 11202:2010)*

EN ISO 11204:2010, *Acoustics — Noise emitted by machinery and equipment — Determination of emission sound pressure levels at a work station and at other specified positions applying accurate environmental corrections (ISO 11204:2010)*

EN ISO 11688-1:2009, *Acoustics — Recommended practice for the design of low-noise machinery and equipment — Part 1: Planning (ISO/TR 11688-1:1995)*

EN ISO 12100:2010, *Safety of machinery — General principles for design — Risk assessment and risk reduction (ISO 12100:2010)*

EN ISO 13849-1:2008, *Safety of machinery — Safety-related parts of controls systems — Part 1: General principles for design (ISO 13849-1:2006)*

EN ISO 13850:2008, *Safety of machinery — Emergency stop — Principles for design (ISO 13850:2006)*

EN ISO 13857:2008, *Safety of machinery — Safety distances to prevent hazard zones being reached by upper and lower limbs (ISO 13857:2008)*

ISO 7960:1995, *Airborne noise emitted by machine tools — Operating conditions for woodworking machines*

3 Terms and definitions

3.1 General

For the purposes of this document, the terms and definitions given in EN ISO 12100:2010 and the following apply.

3.2 Definitions

3.2.1

circular saw bench

hand fed machine fitted with a single main circular saw blade which is fixed in position during the cutting operation, and a horizontal table fixed during operation (see Figure 1)

Note 1 to entry: The saw blade is mounted on a horizontal spindle below the table. The machine may have any of the following features:

- facility for the saw blade to be raised and lowered through the table;
- facility to tilt the saw blade for angled cutting;
- additional, manually operated sliding table;
- facility for scoring;
- facility for grooving with milling tool;
- demountable power feed unit.

iTeh STANDARD PREVIEW
(standards.iteh.ai)
[SIST EN 1870-19:2014](https://standards.iteh.ai/catalog/standards/sist/59ab0695-8cca-44d3-af2a-8e0910e51643/sist-en-1870-19-2014)
<https://standards.iteh.ai/catalog/standards/sist/59ab0695-8cca-44d3-af2a-8e0910e51643/sist-en-1870-19-2014>

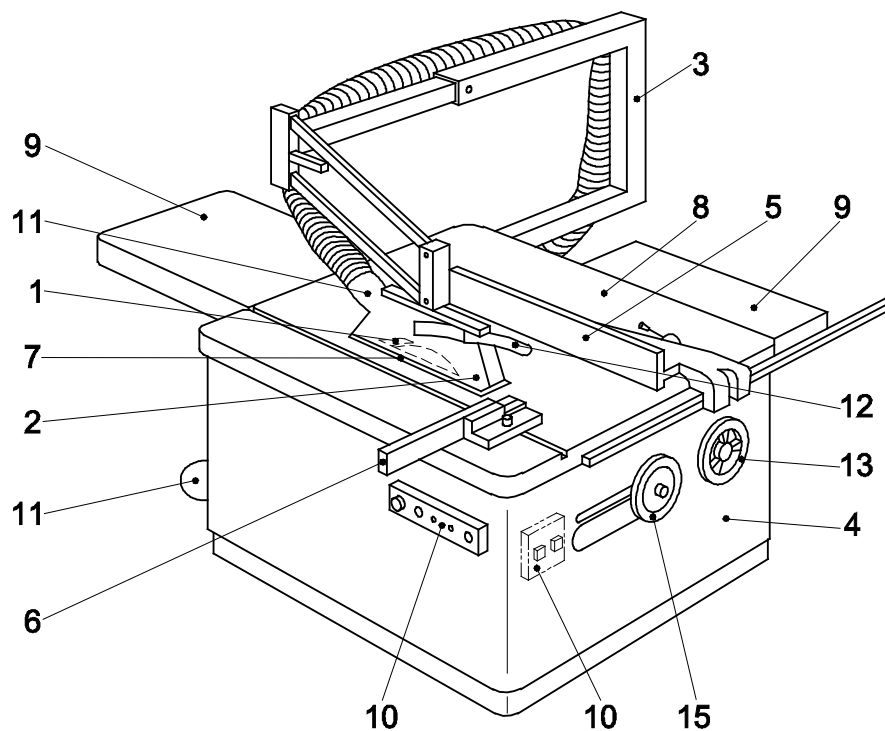

iTeh STANDARD PREVIEW
(standards.iteh.ai)

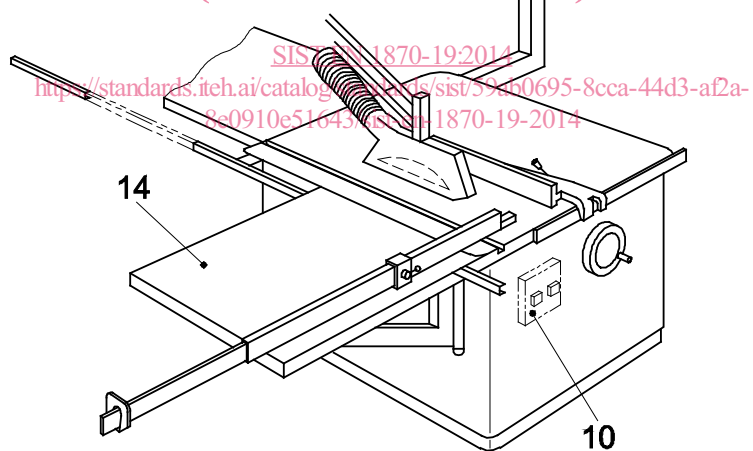

b)

Key

- | | | | |
|---|---------------------------|----|---------------------------|
| 1 | ripping knife | 9 | extension table |
| 2 | saw blade guard | 10 | controls |
| 3 | saw blade guard support | 11 | exhaust outlet |
| 4 | fixed guard beneath table | 12 | push stick |
| 5 | rip fence | 13 | cutting height adjustment |
| 6 | cross-cutting fence | 14 | sliding table |
| 7 | table insert | 15 | inclination adjustment |
| 8 | machine table | | |

Figure 1 — Examples of a circular saw bench

3.2.2 building site saw

hand fed machine fitted with a saw blade mounted under the table designed for use on building sites outdoor and equipped with lifting facility (e.g. lifting eyes)

Note 1 to entry: The saw blade may be adjustable in height and access to it above the table is prevented by an automatically adjustable top guard either mounted on the riving knife (up to saw blade diameter of 500 mm) or separately (see Figure 2).

Note 2 to entry: The machines may have the possibility to be connected to a chip and dust extraction system.

Note 3 to entry: In Nordic countries the term "building site saw" refers to a machine covered by EN 1870-5.

