



**SLOVENSKI STANDARD**  
**SIST EN 14034-3:2006+A1:2011**

**01-maj-2011**

---

**Ugotavljanje eksplozijskih značilnosti oblakov prahu - 3. del: Ugotavljanje spodnje meje eksplozivnosti SME oblakov prahu**

Determination of explosion characteristics of dust clouds - Part 3: Determination of the lower explosion limit LEL of dust clouds

Bestimmung der Explosionskenngrößen von Staub/Luft-Gemischen - Teil 3: Bestimmung der unteren Explosionsgrenze UEG von Staub/Luft-Gemischen

Détermination des caractéristiques d'explosion des nuages de poussière - Partie 3: Détermination de la limite inférieure d'explosivité LIE des nuages de poussière

<https://standards.iteh.ai/catalog/standards/sist/7f95820a-9145-40bc-b562-6161dc2e26bf/sist-en-14034-3-2006a1-2011>

**Ta slovenski standard je istoveten z: EN 14034-3:2006+A1:2011**

---

**ICS:**

13.230            Varstvo pred eksplozijo            Explosion protection

**SIST EN 14034-3:2006+A1:2011**            **en,fr,de**

**iTeh STANDARD PREVIEW**  
**(standards.iteh.ai)**

[SIST EN 14034-3:2006+A1:2011](https://standards.iteh.ai/catalog/standards/sist/7f95820a-9145-40bc-b562-6161dc2e26bf/sist-en-14034-3-2006a1-2011)

<https://standards.iteh.ai/catalog/standards/sist/7f95820a-9145-40bc-b562-6161dc2e26bf/sist-en-14034-3-2006a1-2011>

EUROPEAN STANDARD  
NORME EUROPÉENNE  
EUROPÄISCHE NORM

**EN 14034-3:2006+A1**

January 2011

ICS 13.230

Supersedes EN 14034-3:2006

English Version

## Determination of explosion characteristics of dust clouds - Part 3: Determination of the lower explosion limit LEL of dust clouds

Détermination des caractéristiques d'explosion des nuages de poussière - Partie 3: Détermination de la limite inférieure d'explosivité LIE des nuages de poussière

Bestimmung der Explosionskenngrößen von Staub/Luft-Gemischen - Teil 3: Bestimmung der unteren Explosionsgrenze UEG von Staub/Luft-Gemischen

This European Standard was approved by CEN on 20 April 2006 and includes Amendment 1 approved by CEN on 13 November 2010.

CEN members are bound to comply with the CEN/CENELEC Internal Regulations which stipulate the conditions for giving this European Standard the status of a national standard without any alteration. Up-to-date lists and bibliographical references concerning such national standards may be obtained on application to the CEN-CENELEC Management Centre or to any CEN member.

This European Standard exists in three official versions (English, French, German). A version in any other language made by translation under the responsibility of a CEN member into its own language and notified to the CEN-CENELEC Management Centre has the same status as the official versions.

CEN members are the national standards bodies of Austria, Belgium, Bulgaria, Croatia, Cyprus, Czech Republic, Denmark, Estonia, Finland, France, Germany, Greece, Hungary, Iceland, Ireland, Italy, Latvia, Lithuania, Luxembourg, Malta, Netherlands, Norway, Poland, Portugal, Romania, Slovakia, Slovenia, Spain, Sweden, Switzerland and United Kingdom.

[SIST EN 14034-3:2006+A1:2011](https://standards.iteh.ai/catalog/standards/sist/7f95820a-9145-40bc-b562-6161dc2e26bf/sist-en-14034-3-2006a1-2011)

<https://standards.iteh.ai/catalog/standards/sist/7f95820a-9145-40bc-b562-6161dc2e26bf/sist-en-14034-3-2006a1-2011>



EUROPEAN COMMITTEE FOR STANDARDIZATION  
COMITÉ EUROPÉEN DE NORMALISATION  
EUROPÄISCHES KOMITEE FÜR NORMUNG

Management Centre: Avenue Marnix 17, B-1000 Brussels

## Contents

	Page
Foreword.....	4
Introduction .....	5
<b>1 Scope .....</b>	<b>6</b>
<b>2 Normative references .....</b>	<b>6</b>
<b>3 Terms and definitions .....</b>	<b>6</b>
<b>4 Test apparatus .....</b>	<b>7</b>
4.1 General.....	7
4.2 Explosion vessel.....	7
4.3 Dust dispersion system (dust container, fast acting valve, connecting tube, dust disperser).....	9
4.4 Ignition source .....	12
4.5 Control unit.....	12
4.6 Pressure measuring system.....	12
<b>5 Dust sample.....</b>	<b>12</b>
<b>6 Test procedure .....</b>	<b>12</b>
<b>7 Calibration and verification .....</b>	<b>15</b>
7.1 Calibration .....	15
7.2 Verification .....	15
<b>8 Safety precautions/instructions .....</b>	<b>16</b>
<b>9 Alternative test equipment/procedures.....</b>	<b>16</b>
<b>10 Test report .....</b>	<b>16</b>
<b>Annex A (normative) Electro Pneumatic Valve .....</b>	<b>18</b>
<b>Annex B (normative) Dust disperser with 5 mm holes.....</b>	<b>20</b>
<b>Annex C (normative) 20 l sphere .....</b>	<b>23</b>
C.1 General.....	23
C.2 Test apparatus .....	23
C.3 Test conditions .....	24
C.4 Test procedure .....	24
<b>Annex ZA (informative) <math>\square</math> Relationship between this European Standard and the Essential Requirements of EU Directive 94/9/EC <math>\square</math>.....</b>	<b>26</b>
<b>Bibliography.....</b>	<b>27</b>
<b>Figures</b>	
<b>Figure 1 — 1 m<sup>3</sup> vessel (schematic).....</b>	<b>8</b>
<b>Figure 2 — Dust container with blasting cap activated valve as commonly used for explosion suppression (schematic; it is commercially available) .....</b>	<b>9</b>
<b>Figure 3 — Location of the 6 mm holes in the dust disperser .....</b>	<b>11</b>
<b>Figure 4 — Dust dispersion and pressure-time curve .....</b>	<b>14</b>
<b>Figure 5 — Determination of the lower explosion limit LEL .....</b>	<b>15</b>
<b>Figure A.1 — Electro Pneumatic Valve (schematic).....</b>	<b>18</b>
<b>Figure A.2 — Discharge characteristic of dust dispersers (without dust) .....</b>	<b>19</b>

Figure B.1 — Location of the 5 mm holes in the dust disperser .....	21
Figure B.2 — Rebound nozzle .....	22
Figure B.3 — Dispersion cup .....	22
Figure C.1 — Test equipment 20 l sphere (schematic).....	24

**iTeh STANDARD PREVIEW**  
**(standards.iteh.ai)**

[SIST EN 14034-3:2006+A1:2011](https://standards.iteh.ai/catalog/standards/sist/7f95820a-9145-40bc-b562-6161dc2e26bf/sist-en-14034-3-2006a1-2011)

<https://standards.iteh.ai/catalog/standards/sist/7f95820a-9145-40bc-b562-6161dc2e26bf/sist-en-14034-3-2006a1-2011>

**EN 14034-3:2006+A1:2011 (E)****Foreword**

This document (EN 14034-3:2006+A1:2011) has been prepared by Technical Committee CEN/TC 305 "Potentially explosive atmospheres – Explosion prevention and protection", the secretariat of which is held by DIN.

This European Standard shall be given the status of a national standard, either by publication of an identical text or by endorsement, at the latest by July 2011, and conflicting national standards shall be withdrawn at the latest by July 2011.

Attention is drawn to the possibility that some of the elements of this document may be the subject of patent rights. CEN [and/or CENELEC] shall not be held responsible for identifying any or all such patent rights.

This document includes Amendment 1, approved by CEN on 2010-11-13.

This document supersedes EN 14034-3:2006.

The start and finish of text introduced or altered by amendment is indicated in the text by tags **A1** and **A1**.

This document has been prepared under a mandate given to CEN by the European Commission and the European Free Trade Association, and supports essential requirements of EU Directives.

For relationship with the EU Directive 94/9/EC, see informative Annex ZA, which is an integral part of this document.

[SIST EN 14034-3:2006+A1:2011](https://standards.iteh.ai/catalog/standards/sist/795820a-9145-40bc-b562-6161dc2e26bf/sist-en-14034-3-2006a1-2011)

This European Standard is one of a series of standards as listed below.

EN 14034 "Determination of explosion characteristics of dust clouds"

- Part 1: Determination of the maximum explosion pressure  $p_{max}$  of dust clouds;
- Part 2: Determination of the maximum rate of explosion pressure rise  $(dp/dt)_{max}$  of dust clouds;
- Part 3: Determination of the lower explosion limit LEL of dust clouds;
- Part 4: Determination of the limiting oxygen concentration LOC of dust clouds.

According to the CEN/CENELEC Internal Regulations, the national standards organizations of the following countries are bound to implement this European Standard: Austria, Belgium, Bulgaria, Croatia, Cyprus, Czech Republic, Denmark, Estonia, Finland, France, Germany, Greece, Hungary, Iceland, Ireland, Italy, Latvia, Lithuania, Luxembourg, Malta, Netherlands, Norway, Poland, Portugal, Romania, Slovakia, Slovenia, Spain, Sweden, Switzerland and United Kingdom.

## Introduction

This European Standard specifies a method for experimental determination of the lower explosion limit of dust clouds. The lower explosion limit is the lowest concentration of a combustible dust in mixture with air at which an explosion occurs. The measurement of the lower explosion limit forms the basis for hazard identification and explosion prevention.

A1 *deleted text* A1

## iTeh STANDARD PREVIEW (standards.iteh.ai)

[SIST EN 14034-3:2006+A1:2011](https://standards.iteh.ai/catalog/standards/sist/7f95820a-9145-40bc-b562-6161dc2e26bf/sist-en-14034-3-2006a1-2011)

<https://standards.iteh.ai/catalog/standards/sist/7f95820a-9145-40bc-b562-6161dc2e26bf/sist-en-14034-3-2006a1-2011>

**EN 14034-3:2006+A1:2011 (E)****1 Scope**

This standard describes a test method for the determination of the lower explosion limit of dust clouds in a closed vessel under defined initial conditions of pressure and temperature.

This method is not suitable for use with recognised explosives, like gunpowder and dynamite, explosives which do not require oxygen for combustion, pyrophoric substances, or substances or mixtures of substances which may under some circumstances behave in a similar manner. Where any doubt exists about the existence of hazard due to explosive properties, expert advice should be sought.

**2 Normative references**

The following referenced documents are indispensable for the application of this document. For dated references, only the edition cited applies. For undated references, the latest edition of the referenced document (including any amendments) applies.

EN 14460, *Explosion resistant equipment*

**3 Terms and definitions**

For the purposes of this document, the following terms and definitions apply.

**3.1 dust**  
small solid particles in the atmosphere which settle out under their own weight, but which may remain suspended in air for some time (includes dust and grit, as defined in ISO 4225)

NOTE Generally maximum particle size will not exceed 500 µm.

**3.2 combustible dust**  
dust able to undergo an exothermic reaction with air when ignited

NOTE The terms “flammable” and “combustible” are used synonymously.

**3.3 explosion pressure**  
 $p_{ex}$   
highest overpressure occurring during an explosion of a dust cloud in a closed vessel

**3.4 explosive atmosphere**  
mixture with air, under atmospheric conditions, of flammable (combustible) substances in the form of gases, vapours, mists or dusts, in which, after ignition has occurred, combustion spreads to the entire unburned mixture

**3.5 ignition delay**  
 $t_v$   
time between the initiation of the dust dispersion and the activation of the ignition source



**3.6****initial pressure** $p_i$ 

pressure in the explosion vessel at the moment of ignition

**3.7****initial temperature** $T_i$ 

temperature in the explosion vessel at the moment of ignition

**3.8****lower explosion limit (LEL)**

lowest concentration of a combustible dust in mixture with air at which an explosion occurs

**4 Test apparatus****4.1 General**

The standard test apparatus to determine the lower explosion limit of dust clouds is an explosion pressure resistant vessel of 1 m<sup>3</sup>, as used for the determination of the maximum explosion pressure and the maximum rate of explosion pressure rise of dust clouds as well as the limiting oxygen concentration of dust/air/inert gas mixtures.

The main components of the test apparatus are

- explosion vessel;
- dust dispersion system;
- ignition source;
- control unit;
- pressure measuring system.

**ITEH STANDARD PREVIEW**  
**(standards.iteh.ai)**  
[SIST EN 14034-3:2006+A1:2011](https://standards.iteh.ai/catalog/standards/sist/7f95820a-9145-40bc-b562-6161dc2e26bf/sist-en-14034-3-2006a1-2011)  
<https://standards.iteh.ai/catalog/standards/sist/7f95820a-9145-40bc-b562-6161dc2e26bf/sist-en-14034-3-2006a1-2011>

NOTE The 20 l sphere apparatus is an alternative explosion vessel for these determinations (see Annex C).

**4.2 Explosion vessel**

The standard explosion vessel is an explosion pressure resistant, spherical or cylindrical vessel having a volume of 1 m<sup>3</sup> in accordance with EN 14460. The aspect ratio of the cylindrical vessel shall be 1:1 ± 10 % (see Figure 1).

NOTE It is recommended that the explosion vessel be designed to withstand an overpressure of at least 20 bar.

The apparatus shall be fitted with electrical and/or mechanical cut-offs as far as possible to ensure that any openings in the vessel (e.g. main door, instrument ports, inlet or outlet) are properly closed before a test procedure can start.

The apparatus shall also be equipped as far as possible to ensure that any residual pressure inside the vessel is vented before the vessel can be opened.

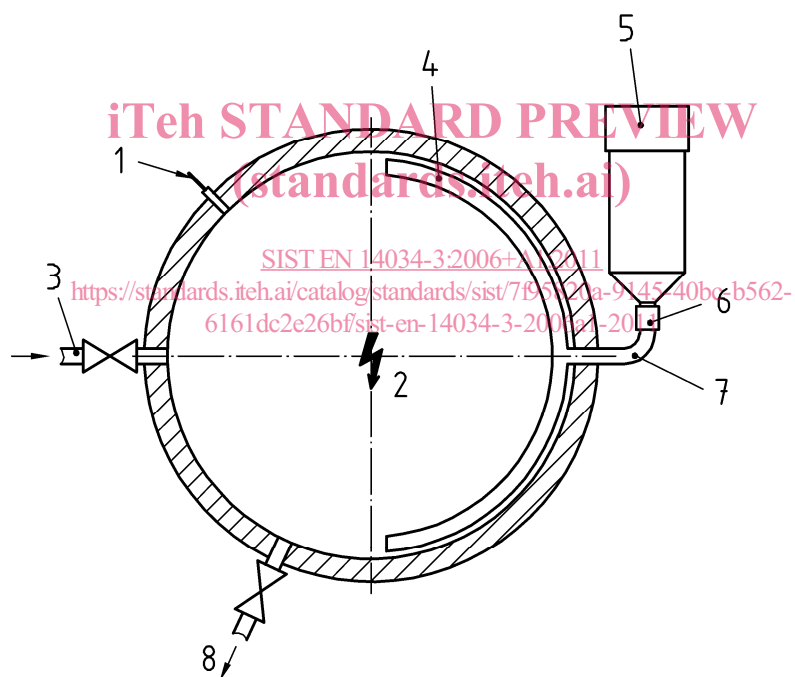
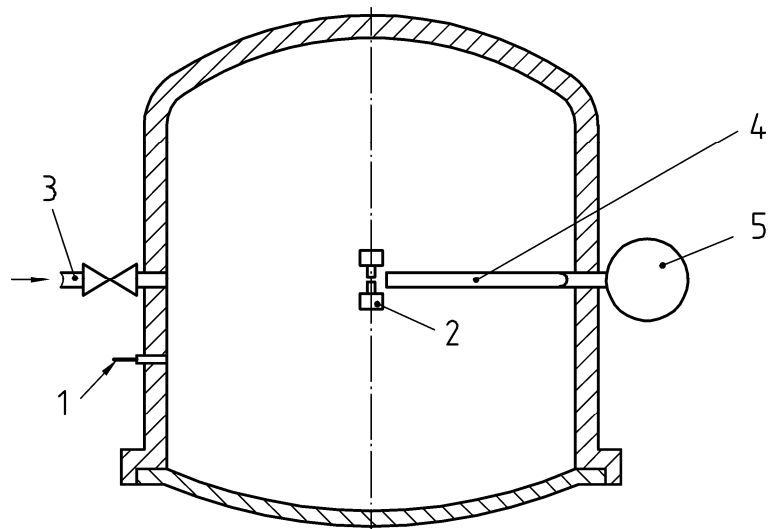
**Key**

- |   |                     |   |                        |
|---|---------------------|---|------------------------|
| 1 | pressure sensor     | 5 | dust container         |
| 2 | chemical igniters   | 6 | fast acting valve      |
| 3 | inlet for purge air | 7 | connecting tube        |
| 4 | dust disperser      | 8 | outlet for exhaust gas |

**Figure 1 — 1 m<sup>3</sup> vessel (schematic)**

### 4.3 Dust dispersion system (dust container, fast acting valve, connecting tube, dust disperser)

The dust to be dispersed is charged into a dust container having a volume of 5,4 dm<sup>3</sup>. Its aspect ratio is 3:1. It is designed to withstand an overpressure of at least 20 bar (see Figure 2).

The dust container has an outlet at the base, through which the dust leaves the container. This outlet is closed by a fast acting valve activated by a blasting cap. The valve has a mushroom-shaped seal. The seal is held in position against the pressure in the dust container by a small ring. The ring is destroyed by firing a blasting cap and the valve opens due to the pressure inside the dust container (see Figure 2). The valve shall be designed so that it opens in less than 10 ms. For alternative valves see Annex A. The fast acting valve is connected to the side of the explosion vessel. The connecting tube between the fast acting valve and the dust disperser shall be not longer than 350 mm (see Figure 1).

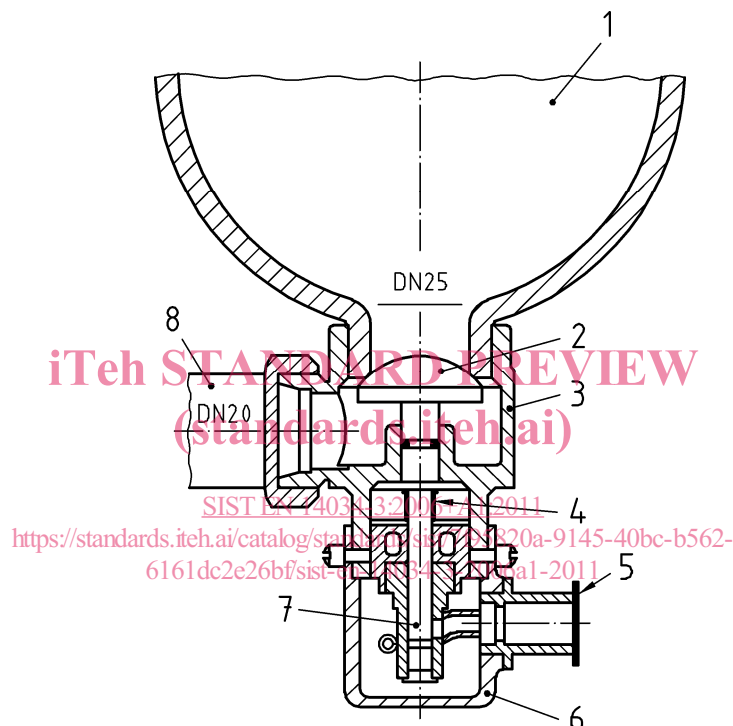

#### Key

- |   |                      |   |                 |
|---|----------------------|---|-----------------|
| 1 | dust container       | 5 | protective hood |
| 2 | mushroom shaped seal | 6 | protective hood |
| 3 | seal housing         | 7 | blasting cap    |
| 4 | support ring         | 8 | connecting tube |

**Figure 2 — Dust container with blasting cap activated valve as commonly used for explosion suppression (schematic; it is commercially available)**

For dispersing the dust, a perforated semicircular spray pipe (dust disperser) is mounted inside the explosion vessel, concentric with its wall. The spray pipe, with an internal diameter of 21,7 mm<sup>1)</sup> is fitted with 13 holes of a diameter of 6 mm (incl. one hole in each end cap) which are located as shown in Figure 3 (see also Figure 1).

1) (e.g. EN ISO 1127, DN 20, 3/4")