



Designation: D6926 – 04

Standard Practice for Preparation of Bituminous Specimens Using Marshall Apparatus¹

This standard is issued under the fixed designation D6926; the number immediately following the designation indicates the year of original adoption or, in the case of revision, the year of last revision. A number in parentheses indicates the year of last reapproval. A superscript epsilon (ϵ) indicates an editorial change since the last revision or reapproval.

1. Scope

1.1 This practice covers preparation and compaction of 102 mm (4 in.) diameter by nominal 64 mm (2.5 in.) high cylindrical bituminous paving mixture specimens by means of the original manual Marshall method and subsequent variations of the method. This practice is intended for use with laboratory and plant produced bituminous mixtures with aggregate up to 25 mm (1 in.) maximum size and for recompaction of asphalt pavement samples.

1.2 There are three types of Marshall compaction apparatus in use. The following types of hammer arrangements are included in this practice:

1.2.1 Manually held hammer handle attached to a flat compaction foot through a spring loaded swivel and is hand operated (original standard developed by the Corps of Engineers).

1.2.2 Hammer handle restrained laterally (fixed) but not vertically attached to a flat compaction foot through a spring loaded swivel and is either mechanically or hand operated. There may or may not be a constant surcharge on top of the hammer handle. Mechanical hammers are available that operate at (1) nominal 55 blows per minute and (2) equal to or greater than 75 blows per minute.

1.2.3 Hammer handle restrained laterally (fixed) with constant surcharge on top of hammer, a slanted compaction foot, rotating mold base, and is mechanically operated.

1.3 Although the mass and height of mass drop for each apparatus are the same, density achieved in compacted specimens with the same number of blows will be different. It is up to the user to establish the specific required number of blows to be used for compaction of the specimen in relation to the field.

2. Referenced Documents

2.1 *ASTM Standards*:²

¹ This practice is under the jurisdiction of ASTM Committee D04 on Road and Paving Materials and is the direct responsibility of Subcommittee D04.20 on Mechanical Tests of Bituminous Mixes.

Current edition approved Aug. 1, 2004. Published August 2004. DOI: 10.1520/D6926-04.

² For referenced ASTM standards, visit the ASTM website, www.astm.org, or contact ASTM Customer Service at service@astm.org. For *Annual Book of ASTM Standards* volume information, refer to the standard's Document Summary page on the ASTM website.

D2171 Test Method for Viscosity of Asphalts by Vacuum Capillary Viscometer

D2493 Standard Viscosity-Temperature Chart for Asphalts

D4402 Test Method for Viscosity Determination of Asphalt at Elevated Temperatures Using a Rotational Viscometer

E11 Specification for Woven Wire Test Sieve Cloth and Test Sieves

3. Significance and Use

3.1 Compacted bituminous mixture specimens molded by this procedure are used for various physical tests such as stability, flow, indirect tensile strength, fatigue, creep, and modulus. Density and voids analysis are also conducted on specimens for mixture design and evaluation of field compaction.

NOTE 1—Uncompacted mixtures are used for determination of theoretical maximum specific gravity.

4. Apparatus

4.1 *Specimen Mold Assembly*—Mold cylinders, base plates, and extension collars shall conform to the details shown in Fig. 1.

4.2 *Specimen Extractor*—The specimen extractor shall have a steel disk that will enter the mold without binding and not be less than 100 mm (3.95 in.) in diameter and 12.5 mm (½ in.) thick. The steel disk is used for extracting compacted specimens from molds with the use of the mold collar. Any suitable extraction device such as a hydraulic jack apparatus or a lever arm device may be used, provided the specimens are not deformed during the extraction process.

4.3 *Compaction Hammers*:

4.3.1 *Compaction Hammers with a Manually Held (Type 1) or Fixed (Type 2) Handle*, either mechanically or hand operated as generally shown in Fig. 2, shall have a flat, circular compaction foot with spring loaded swivel and a 4.54 ± 0.01 kg (10 ± 0.02 lb) sliding mass with a free fall of 457.2 ± 1.5 mm (18 ± 0.06 in.) (see Fig. 2 for hammer tolerances). A mechanical hammer is shown in Fig. 3.

NOTE 2—Manual compaction hammers should be equipped with a finger safety guard.

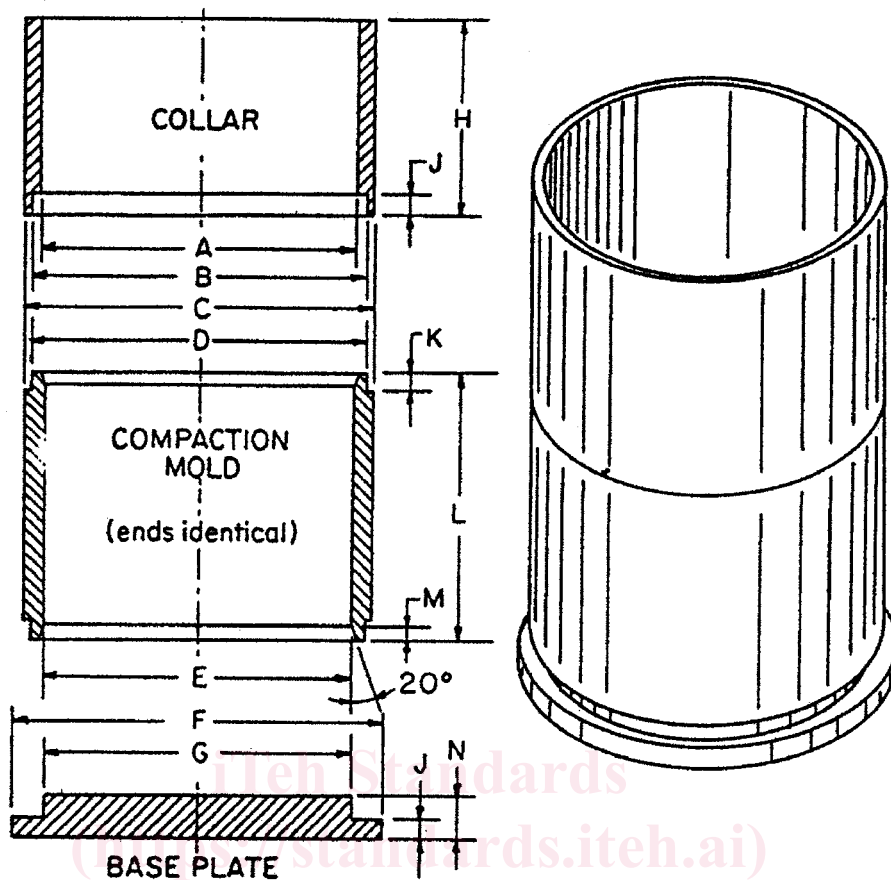

	mm	in.
A	104.1 to 105.4	4.100 to 4.150
B	109.1 to 110.2	4.295 to 4.349
C	114.0 to 115.8	4.490 to 4.560
D	107.0 to 109.7	4.211 to 4.320
E	101.3 to 101.7	3.990 to 4.005
F	119.9 to 121.4	4.720 to 4.780
G	101.1 to 101.3	3.980 to 3.990
H	69.3 to 70.4	2.730 to 2.770
J	7.0 to 7.2	0.235 to 0.285
K	6.1 to 6.7	0.235 to 0.265
L	86.9 to 87.9	3.420 to 3.460
M	3.0 to 4.8	0.120 to 0.190
N	12.3 to 14.9	0.485 to 0.585

FIG. 1 Compaction Mold

4.3.2 *Compaction Hammers with a Fixed Hammer Handle*, surcharge on top of handle, constantly rotating base, and mechanically operated (Type 3) as generally shown in Fig. 4 shall have a slanted, circular tamping face and a 4.54 ± 0.01 kg (10 ± 0.02 lb) sliding weight with a free fall of 457.2 ± 1.5 mm (18 ± 0.06 in.) (see Fig. 2 and Fig. 4 for hammer and tamping face bevel angle and tolerances, respectively). A rotating mechanism is incorporated in the base. The base rotation rate and hammer blow rate shall be 18 to 30 rpm and 64 ± 4 blows per minute, respectively.

NOTE 3—Type 3 Marshall hammer apparatus are available in versions with more than one hammer. Multiple hammer operation will affect specimen density. Best comparative results will be obtained by compact-

ing all specimens with the same hammer and with no other hammers operating.

4.4 *Compaction Pedestal*—The compaction pedestal shall consist of a nominal 203.2 by 203.2 mm (8 by 8 in.) wooden post approximately 457 mm (18 in.) long capped with a steel plate approximately 304.8 by 304.8 mm (12 by 12 in.) and 25.4 mm (1 in.) thick. The wooden post shall be oak, yellow pine, or other wood having an average dry density of 670 to 770 kg/m³ (42 to 48 lb/ft³). The wooden post shall be secured by bolts through four angle brackets to a solid concrete slab. The steel cap shall be firmly fastened to the post. The pedestal assembly shall be installed so that the post is plumb and the cap is level.

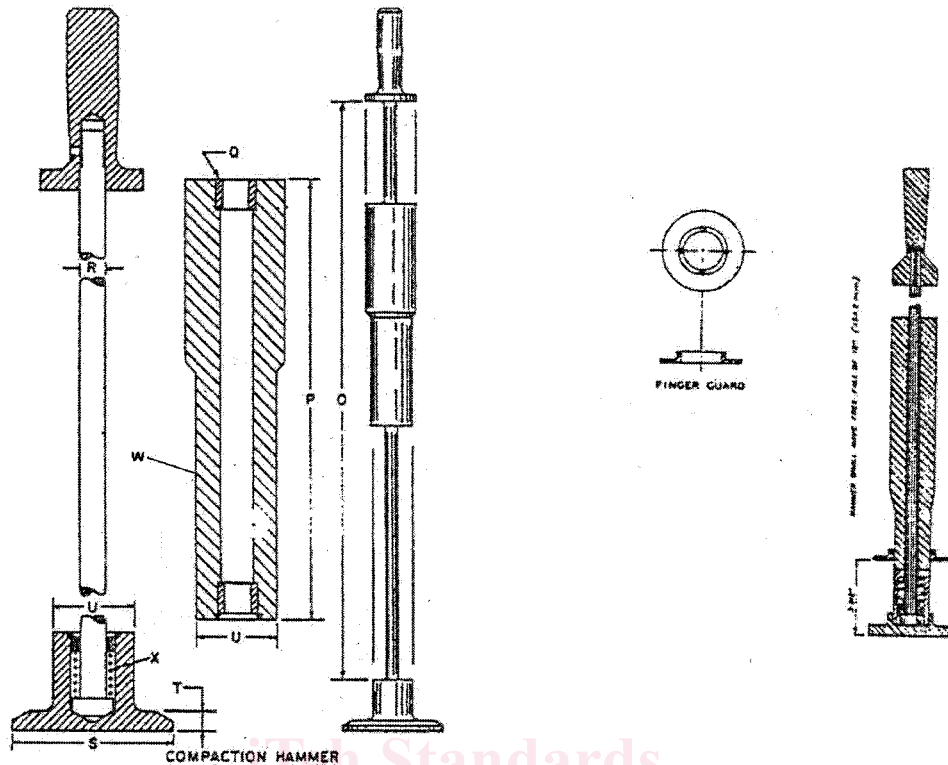

- O minus P
- Q Bronze bushings
- R Minimum nominal diameter of 0.625 in. (15.9 mm) and with suitable corrosion resistance
- S Face hardened. Impact resistant material
- T
- U
- W
- X Spring loaded swivel between guide rod and foot—details optional

	mm	in.
	456.6 to 457.8	17.975 to 18.025
	15.9	0.625
	98.0 to 100.0	3.860 to 3.950
	11.5 to 14.0	0.450 to 0.550
	49.8 to 51.8	1.960 to 2.040
	kg	lb
	4.53 to 4.55	9.98 to 10.02

FIG. 2 Manual Compaction Hammer

4.5 *Specimen Mold-Holder*—With single hammer compactors, the holder shall be mounted on the compaction pedestal so as to center the compaction mold over the center of the post. Specimen mold-holders of multi-hammer compactors are not necessarily centered. The holders shall hold the compaction mold, collar, and base plate securely in position during compaction of the specimen.

4.6 *Ovens, Heating Pots or Hot Plates*—Circulating air ovens or thermostatically controlled heating pot and hot plates shall be provided for heating aggregates, bituminous material, specimen molds, compaction hammers, and other equipment to within 3°C (5°F) of the required mixing and compaction temperatures. Suitable shields, baffle plates, or sand baths shall be used on the surfaces of the hot plates to minimize localized overheating.

4.7 *Mixing Apparatus*—Mechanical mixing is recommended. Any type of mechanical mixer may be used provided the mix can be maintained at the required temperature and mixing will produce a well-coated, homogeneous mixture of the required amount in the allowable time, and further provided

that essentially all of the batch can be recovered. A metal pan or bowl of sufficient capacity for hand mixing may also be used.

4.8 *Miscellaneous Equipment:*

4.8.1 *Containers for Heating Aggregates*, flat-bottom metal pans, or other suitable containers.

4.8.2 *Covered Containers for Heating Bituminous Material*, either gill-type tins, beakers, pouring pots, or saucepans may be used.

4.8.3 *Mixing Tools*, shall consist of a steel trowel (Mason's pointing trowel with point rounded), spoon or spatula, for spading and hand mixing.

4.8.4 *Calibrated Thermometers*, for determining temperatures of aggregates, bitumen, and bituminous mixtures. Armored-glass or dial-type thermometers with metal stems are recommended. A range from 10 to 200°C (50 to 400°F) with sensitivity of 3°C (5°F) is required.

4.8.5 *Balance*, readable to at least 0.1 g for batching mixtures.

4.8.6 *Gloves*, for handling hot equipment.