



**SLOVENSKI STANDARD**  
**SIST EN 13683:2004+A2:2011**  
**01-maj-2011**

---

**Oprema za nego vrta - Motorni drobilniki/sekalniki - Varnost**

Garden equipment - Integrally powered shredders/chippers - Safety

Gartengeräte - Motorgetriebene Schredder/Zerkleinerer - Sicherheit

Matériel de jardinage - Broyeurs/déchiqueteurs à moteur intégré - Sécurité

**Ta slovenski standard je istoveten z: EN 13683:2003+A2:2011**

[SIST EN 13683:2004+A2:2011](https://standards.iteh.ai/catalog/standards/sist/d5455601-6d0d-4c21-9542-b65d9325be1c/sist-en-13683-2004a2-2011)

<https://standards.iteh.ai/catalog/standards/sist/d5455601-6d0d-4c21-9542-b65d9325be1c/sist-en-13683-2004a2-2011>

**ICS:**

65.060.70      Vrtnarska oprema      Horticultural equipment

**SIST EN 13683:2004+A2:2011**      en,fr

**iTeh STANDARD PREVIEW**  
**(standards.iteh.ai)**

SIST EN 13683:2004+A2:2011

<https://standards.iteh.ai/catalog/standards/sist/d5455601-6d0d-4c21-9542-b65d9325be1c/sist-en-13683-2004a2-2011>

EUROPEAN STANDARD

**EN 13683:2003+A2**

NORME EUROPÉENNE

EUROPÄISCHE NORM

March 2011

ICS 65.060.70

Supersedes EN 13683:2003+A1:2009

English Version

## Garden equipment - Integrally powered shredders/chippers - Safety

Matériel de jardinage - Broyeurs/déchiqueteurs à moteur  
intégré - SécuritéGartengeräte - Motorgetriebene Schredder/Zerkleinerer -  
Sicherheit

This European Standard was approved by CEN on 8 September 2003 and includes Amendment 1 approved by CEN on 14 March 2009 and Amendment 2 approved by CEN on 3 December 2010.

CEN members are bound to comply with the CEN/CENELEC Internal Regulations which stipulate the conditions for giving this European Standard the status of a national standard without any alteration. Up-to-date lists and bibliographical references concerning such national standards may be obtained on application to the CEN-CENELEC Management Centre or to any CEN member.

This European Standard exists in three official versions (English, French, German). A version in any other language made by translation under the responsibility of a CEN member into its own language and notified to the CEN-CENELEC Management Centre has the same status as the official versions.

CEN members are the national standards bodies of Austria, Belgium, Bulgaria, Croatia, Cyprus, Czech Republic, Denmark, Estonia, Finland, France, Germany, Greece, Hungary, Iceland, Ireland, Italy, Latvia, Lithuania, Luxembourg, Malta, Netherlands, Norway, Poland, Portugal, Romania, Slovakia, Slovenia, Spain, Sweden, Switzerland and United Kingdom.

[SIST EN 13683:2004+A2:2011](https://standards.iteh.ai/catalog/standards/sist/d5455601-6d0d-4c21-9542-b65d9325be1c/sist-en-13683-2004a2-2011)

<https://standards.iteh.ai/catalog/standards/sist/d5455601-6d0d-4c21-9542-b65d9325be1c/sist-en-13683-2004a2-2011>



EUROPEAN COMMITTEE FOR STANDARDIZATION  
COMITÉ EUROPÉEN DE NORMALISATION  
EUROPÄISCHES KOMITEE FÜR NORMUNG

Management Centre: Avenue Marnix 17, B-1000 Brussels

Contents	Page
Foreword .....	4
0 Introduction .....	5
1 Scope .....	6
2 Normative references .....	6
3 Terms and definitions .....	7
4 List of significant hazards .....	11
5 Safety requirements and/or measures .....	13
5.1 General .....	13
5.2 Access to power driven components .....	13
5.2.1 Feed safety openings .....	13
5.2.2 Discharge chutes .....	22
5.2.3 Guards .....	26
5.2.4 Power driven components except cutting means .....	26
5.3 Hot exhaust surfaces .....	27
5.3.1 General .....	27
5.3.2 Test equipment and method of test .....	27
5.3.3 Test acceptance .....	27
5.4 Controls .....	29
5.4.1 Location .....	29
5.4.2 Stopping and starting the power source .....	29
5.4.3 Identification of controls .....	29
5.5 Protection from exhaust fumes .....	29
5.6 Electrical requirements .....	29
5.6.1 General .....	29
5.6.2 Low voltage battery circuits (not including magneto grounding circuits) .....	29
5.6.3 Overload protection .....	30
5.6.4 Terminals and uninsulated electrical parts .....	30
5.7 Liquid spillage .....	30
5.8 Transport .....	30
5.9 Verification of safety requirements .....	30
5.9.1 Test conditions .....	30
5.9.2 Thrown object test (see 5.2.3.1) .....	31
5.9.3 Stability .....	34
5.9.4 Dynamic stability test .....	34
5.10 Noise .....	35
5.10.1 Noise reduction as a safety requirement .....	35
5.10.2 Verification of requirements on noise – Noise measurement .....	35
6 Information for use .....	36
6.1 Instruction for use .....	36
6.2 Marking .....	37
6.2.1 Minimum marking .....	37
6.2.2 Warning marking .....	38
6.2.3 Marking durability .....	38
6.2.4 Test .....	38
Annex A (informative) $\text{A}_2$ Examples of inlet openings where the safety distance is ≥ 200 mm (see 5.2.1.3) $\text{A}_2$ .....	39
Annex B (normative) Test enclosure .....	42
Annex C (normative) Target panels - Specification for corrugated fibreboard (see 5.9.2) .....	44

C.1	Corrugated fibreboard target panel composition .....	44
C.2	Corrugated fibreboard penetration test .....	44
C.2.1	General .....	44
C.2.2	Test fixture .....	44
C.2.3	Corrugated fibreboard samples .....	44
C.2.4	Procedure .....	44
C.2.5	Acceptance criteria .....	45
Annex D	(informative) Safety instructions .....	47
D.1	General .....	47
D.2	Safe operating practices .....	47
D.2.1	Training .....	47
D.2.2	Preparation .....	47
D.2.3	Operation .....	48
D.2.4	Maintenance and storage .....	49
D.2.5	Additional safety instructions for units with bagging attachments .....	49
Annex E	(normative) Symbols and/or pictograms .....	50
E.1	General .....	50
E.2	Pictograms .....	50
Annex F	(normative) Noise test code – Engineering method (grade 2) .....	52
F.1	Scope .....	52
F.2	A-weighted sound power level determination .....	52
F.3	A-weighted emission sound pressure level measurement .....	53
F.4	Requirements for test floor .....	57
F.4.1	Artificial surface .....	57
F.4.2	Natural grass .....	57
F.5	Installation, mounting and operating conditions .....	57
F.6	Measurement uncertainties and declaration of noise emission values .....	58
F.7	Information to be recorded and reported .....	58
Annex G	(informative) Example of a material and construction fulfilling the requirements for an artificial surface .....	59
G.1	Material .....	59
G.2	Construction .....	59
Annex ZA	(informative) $\square_{A2}$ Relationship between this European Standard and the Essential Requirements of EU Directive 2006/42/EC $\square_{A2}$ .....	61
Bibliography	.....	62

## EN 13683:2003+A2:2011 (E)

## Foreword

This document (EN 13683:2003+A2:2011) has been prepared by Technical Committee CEN/TC 144 "Tractors and machinery for agriculture and forestry", the secretariat of which is held by AFNOR.

This European Standard shall be given the status of a national standard, either by publication of an identical text or by endorsement, at the latest by September 2011, and conflicting national standards shall be withdrawn at the latest by September 2011.

This document includes Amendment 1, approved by CEN on 2009-03-14 and Amendment 2, approved by CEN on 2010-12-13.

This document supersedes  $\boxed{A_2}$  EN 13683:2003+A1:2009  $\boxed{A_2}$ .

The start and finish of text introduced or altered by amendment is indicated in the text by tags  $\boxed{A_1}$   $\boxed{A_1}$  and  $\boxed{A_2}$   $\boxed{A_2}$ .

$\boxed{A_2}$  *deleted text*  $\boxed{A_2}$

This document has been prepared under a mandate given to CEN by the European Commission and the European Free Trade Association, and supports essential requirements of EU Directive(s).

$\boxed{A_1}$  For relationship with EU Directive(s), see informative  $\boxed{A_2}$  Annex ZA  $\boxed{A_2}$ , which  $\boxed{A_2}$  is an integral part  $\boxed{A_2}$  of this document.  $\boxed{A_1}$

Attention is drawn to the possibility that some of the elements of this document may be the subject of patent rights. CEN [and/or CENELEC] shall not be held responsible for identifying any or all such patent rights.

Annexes A, D and G are informative. Annexes B, C, E and F are normative.

This document includes a Bibliography.

According to the CEN/CENELEC Internal Regulations, the national standards organizations of the following countries are bound to implement this European Standard: Austria, Belgium, Bulgaria, Croatia, Cyprus, Czech Republic, Denmark, Estonia, Finland, France, Germany, Greece, Hungary, Iceland, Ireland, Italy, Latvia, Lithuania, Luxembourg, Malta, Netherlands, Norway, Poland, Portugal, Romania, Slovakia, Slovenia, Spain, Sweden, Switzerland and United Kingdom.

## 0 Introduction

This document is a type C standard as stated in EN 1070:1998.

The machinery concerned and the extent to which hazards, hazardous situations and events are covered are indicated in the scope of this document.

When provisions of this type C standard are different from those which are stated in type A or B standards, the provisions of this type C standard take precedence over the provisions of the other standards, for machines that have been designed and built according to the provisions of this type C standard.

## iTeh STANDARD PREVIEW (standards.iteh.ai)

[SIST EN 13683:2004+A2:2011](https://standards.iteh.ai/catalog/standards/sist/d5455601-6d0d-4c21-9542-b65d9325be1c/sist-en-13683-2004a2-2011)

<https://standards.iteh.ai/catalog/standards/sist/d5455601-6d0d-4c21-9542-b65d9325be1c/sist-en-13683-2004a2-2011>

**EN 13683:2003+A2:2011 (E)****1 Scope**

This European Standard specifies safety requirements and their verification for the design and construction of hand fed, shredders/chippers with integral power source and with or without vacuum assisted collection which are designed primarily to reduce organic material to smaller pieces. It is only applicable to shredders/chippers that are designed for use outdoors in a stationary position by an operator standing on the ground. <sup>A2</sup> This standard applies to shredders/chippers with feed intake openings or segments, in this standard referred to as feed safety openings and being of any shape complying with the safety distance requirements of this standard with regard to contact with the cutting means, that in total will fit into a square of 250 mm × 250 mm measured at the plane of the opening(s). <sup>A2</sup>

<sup>A2</sup> *deleted text* <sup>A2</sup>

This standard describes methods of elimination or reduction of hazards arising from the use of shredders/chippers. In addition it specifies the type of information to be provided by the manufacturer on safe working practices.

This standard does not cover requirements for:

- units driven by an external power source;
- mobile use of units which can be used in both stationary and mobile modes;
- units with powered discharge intended to broadcast material or load vehicles;

<sup>A2</sup>

- units with separate mechanically powered feed intake or attachments; <sup>A2</sup>  
<https://standards.iteh.ai/catalog/standards/sist/d5455601-6d0d-4c21-6b15-020c20c00000/EN-13683-2004+A2-2011>
- units with cutting means of either one or more non-metallic filaments, or one or more non-metallic cutting elements pivotally mounted on a generally circular central drive unit, where these cutting elements rely on centrifugal force to achieve cutting, and have a kinetic energy for each single cutting means of less than 10 J;

<sup>A2</sup>

- electrical powered and battery-powered shredders/chippers. <sup>A2</sup>

Environmental hazards and EMC have not been considered in this standard.

This standard deals with all significant hazards, hazardous situations and events relevant to shredders/chippers, when they are used as intended (see clause 4).

This document is not applicable to shredders/chippers which are manufactured before the date of publication of this document by CEN.

**2 Normative references**

This European Standard incorporates, by dated or undated reference, provisions from other publications. These normative references are cited at the appropriate places in the text and the publications are listed hereafter. For dated references, subsequent amendments to or revisions of any of these publications apply to this European Standard only when incorporated in it by amendment or revision. For undated references the latest edition of the publication referred to applies (including amendments).

<sup>A2</sup> *deleted text* <sup>A2</sup>



EN 953:1997+A1:2009, *Safety of machinery — Guards — General requirements for the design and construction of fixed and movable guards* <sup>A2</sup>

EN 954-1:1996, *Safety of machinery — Safety-related parts of control systems — Part 1: General principles for design.*

EN 1070:1998, *Safety of machinery — Terminology.*

EN 61032:1998, *Protection of persons and equipment by enclosures — Probes for verification (IEC 61032:1997)* <sup>A2</sup>

EN ISO 354:2003, *Acoustics — Measurement of sound absorption in a reverberation room (ISO 354:2003).*

EN ISO 3744:1995, *Acoustics — Determination of sound power levels of noise sources using sound pressure — Engineering method in an essentially free field over a reflecting plane (ISO 3744:1994).*

EN ISO 11201:1995, *Acoustics — Noise emitted by machinery and equipment — Measurement of emission sound pressure levels at a work station and at other specified positions — Engineering method in an essentially free field over a reflecting plane (ISO 11201:1995).*

EN ISO 11688-1:1998, *Acoustics — Recommended practice for the design of low-noise machinery and equipment — Part 1: Planning (ISO/TR 11688-1:1995).*

EN ISO 12100-1:2003, *Safety of machinery — Basic concepts, general principles for design — Part 1: Basic terminology, methodology (ISO 12100-1:2003)*

EN ISO 12100-2:2003, *Safety of machinery — Basic concepts, general principles for design — Part 2: Technical principles (ISO 12100-2:2003)*

EN ISO 13849-1:2008, *Safety of machinery — Safety-related parts of control systems — Part 1: General principles for design (ISO 13849-1:2006)*

EN ISO 13857:2008, *Safety of machinery — Safety distances to prevent hazard zones being reached by upper and lower limbs (ISO 13857:2008)* <sup>A2</sup>

ISO 3767-1:1998, *Tractors, machinery for agriculture and forestry, powered lawn and garden equipment — Symbols for operator controls and other displays — Part 1: Common symbols.*

ISO 3767-3:1995, *Tractors, machinery for agriculture and forestry, powered lawn and garden equipment — Symbols for operator controls and other displays — Part 3: Symbols for powered lawn and garden equipment.*

ISO 3767-4:1993, *Tractors, machinery for agriculture and forestry, powered lawn and garden equipment — Symbols for operator controls and other displays — Part 4: Symbols for forestry machinery.*

ISO 3864-1:2002, *Graphical symbols — Safety colours and safety signs — Part 1: Design principles for safety signs in workplaces and public areas.*

ISO 11684:1995, *Tractors, machinery for agriculture and forestry, powered lawn and garden equipment — Safety signs and hazard pictorials — General principles.*

### 3 Terms and definitions

For the purposes of this European Standard, the terms and definitions given in EN 1070:1998 and the following apply.

**EN 13683:2003+A2:2011 (E)****3.1****discharge chute**

extension of the opening through which the shredded or chipped material is discharged

**3.2****discharge zone**

any space wherein material is intended to be ejected from the machine

**3.3****exhaust system**

means of conveying exhaust gases from the power source to the atmosphere

**3.4****feed safety opening**

opening through which material is passed located at the relevant safety distance from the cutting means. This may be the same as the feed intake opening (3.5) or at some point between the feed intake opening and the cutting means. It is *W* in Table 1

**3.5****feed intake opening**

opening through which material is inserted to be fed to the cutting mechanism. A feed intake opening can become feed safety opening(s) if the relevant safety distance from the cutting means is met

**3.6****normal operation**

any use of the machine which is specified by the manufacturer, and which is consistent with such activities as reducing organic material, starting, stopping, and fuelling

**3.7****normal use**

normal operation, plus routine maintenance, servicing, cleaning, transporting, attaching or removing accessories, and making adjustments as determined by the manufacturer's instructions

**3.8****material discharge deflector**

fixed or movable component used to direct the flow of processed material discharging from the machine

**3.9****maximum operating speed**

highest power source speed obtainable when adjusted in accordance with manufacturer's specifications and/or instructions with the cutting means engaged

**Ⓐ<sub>2</sub> 3.10****operator presence control**

device that automatically interrupts power to the cutting means when the operator's actuating force is removed Ⓐ<sub>2</sub>

**3.11****power source**

engine or motor which provides energy for linear or rotational movement

**3.12****screen (grid)**

perforated metal piece or bar(s) located between the cutting means and discharge chute or opening of the machine to assist in reducing bulk organic materials to smaller pieces

**3.13****shredder/chipper**

machine designed for use in a stationary position having one or more cutting means for the purpose of reducing organic materials to smaller pieces. See Figures 1, 2 and 3

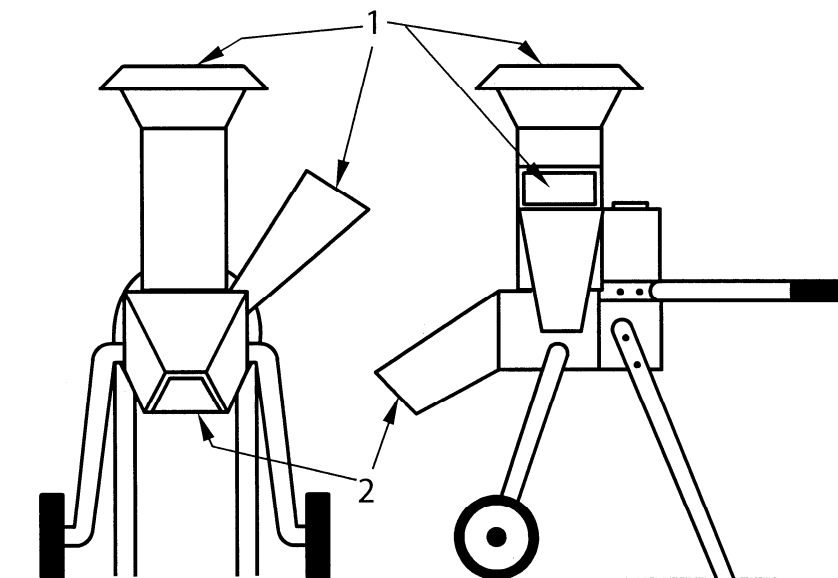

**iTeh STANDARD PREVIEW**  
**(standards.iteh.ai)**

**Key**

- 1 Feed intake opening
- 2 Discharge chute

[SIST EN 13683:2004+A2:2011](https://standards.iteh.ai/catalog/standards/sist/d5455601-6d0d-4c21-9542-b65d9325be1c/sist-en-13683-2004a2-2011)

<https://standards.iteh.ai/catalog/standards/sist/d5455601-6d0d-4c21-9542-b65d9325be1c/sist-en-13683-2004a2-2011>

**Figure 1**

EN 13683:2003+A2:2011 (E)

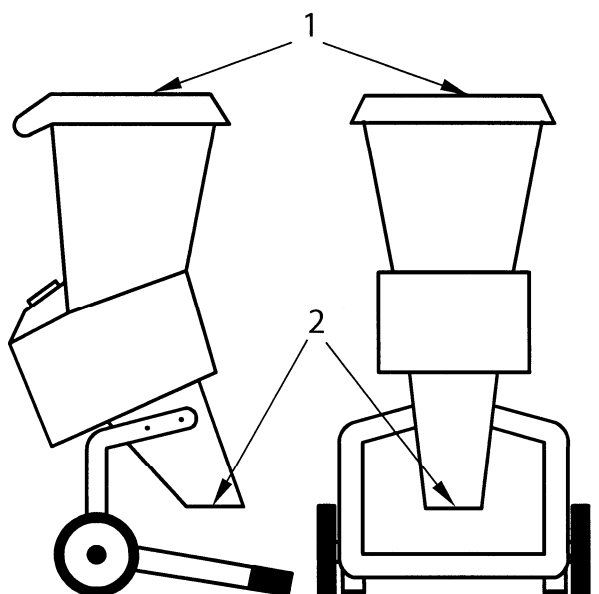
**Key**

- 1 Feed intake opening
- 2 Discharge chute

**iTeh STANDARD PREVIEW**  
 (standardsiteh.ai)  
 Figure 2

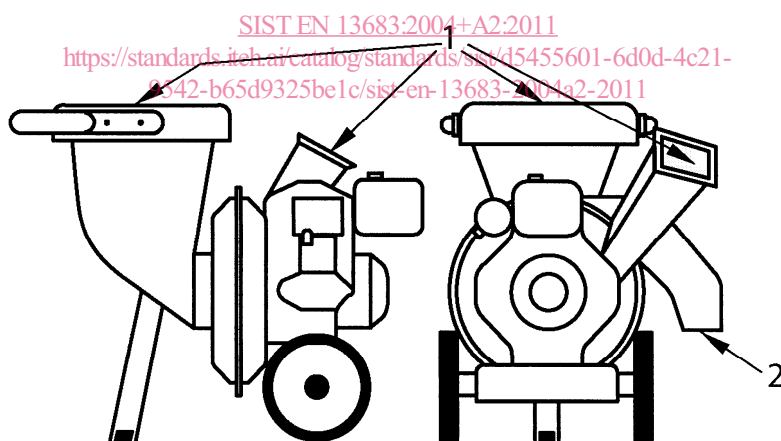
**Key**

- 1 Feed intake opening
- 2 Discharge chute

**Figure 3**

**Figures 1, 2 and 3 — Examples of typical shredders/chippers**

#### 4 List of significant hazards

This clause contains for defined danger zones all the significant hazards, hazardous situations and events, as far as they are dealt with in this standard, identified by risk assessment as significant for these types of machines and which require specific action by the designer or manufacturer to eliminate or to reduce the risk (see Table 1). It is the responsibility of the manufacturer to check whether or not the safety requirements recommended by the standard apply to each significant hazard presented by its specific machine and to validate that the risk assessment is complete with particular attention to:

- intended use of the machine including maintenance, setting and cleaning and its reasonably foreseeable misuse;
- identification of all significant hazards associated with the machine.

**Table 1 — List of significant hazards associated with shredders/chippers**

Ref. No.	Hazard	Location or event	Reference of this standard
Hazards, hazardous situations and hazardous events			
	<b>Mechanical hazards</b> due to:		
	- machine parts or workpieces, e.g.:		
	a) relative location;	Safe positioning of the machine	6.1; annex D
	b) mass and velocity (kinetic energy of elements in controlled or uncontrolled motion);	Dynamic stability of machine	5.9.4
	c) inadequacy of mechanical strength;	Guard failure/strength	5.2.3.2
1.3	Cutting or severing hazard	Feeding material into the machine	5.2.1; 6.1; annex D
		Clearing processed material from discharge chute	5.2.2; 6.1; annex D
1.4	Entanglement hazard	Feeding material into the cutting means	6.1; 6.2; annex D
1.5	Drawing-in or trapping hazard	Feeding material into the cutting means	5.2.1; 6.1; annex D
1.6	Impact hazard	Thrown objects	5.2.3.1; 5.9.2; 6.1; annex D
2	<b>Electrical hazards</b> due to:		
2.1	Contact of persons with live parts (direct contact)	High voltage and ignition parts	5.6.4
2.2	Contact of persons with parts which have become live under faulty conditions (indirect contact)	Damage caused by oil, fuel, abrasion etc	5.6.2.1
3	<b>Thermal hazards</b> , resulting in:		
3.1	Burns, scalds and other injuries by a possible contact of persons with objects or materials with an extreme high or low temperature, by flames or explosions and also by the radiation of heat sources	Contact with hot parts	5.3
4	<b>Hazards generated by noise</b> , resulting in:		
4.1	Hearing loss (deafness), other physiological disorders (e.g. loss of balance, loss of awareness)	Hearing damage due to machine and/or processing of material	5.10; 6.1; 6.2; annexes D, F and G

## EN 13683:2003+A2:2011 (E)

Table 1 (continued) — List of significant hazards associated with shredders/chippers

7	<b>Hazards generated by materials and substances</b> (and their constituent elements) processed or used by the machinery		
7.1	Hazards from contact with or inhalation of harmful fluids, gases, mists, fumes, and dusts	Breathing of engine exhaust fumes	5.5; 6.1 and annex D
7.2	Fire or explosion hazard	Refuelling	6.1 and annex D
8	<b>Hazards generated by neglecting ergonomic principles in machinery design</b> as, e.g. hazards from:		
8.1	Unhealthy postures or excessive effort	Handling during moving machine	5.8; 6.1; annex D
8.3	Neglected use of personal protection equipment	Protect against noise and thrown objects,	5.10; 6.1; annex D
8.6	Human error, human behaviour	Incorrect use etc. Keep bystanders away	6.1; annex D 6.2
8.7	Inadequate design, location or identification of manual controls	Location of stop/start control(s)	5.4.1
		Identification of control(s)	5.4.3
10	<b>Unexpected start-up, unexpected over-run/over-speed</b> (or any similar malfunction) from:		
10.2	Restoration of energy supply after an interruption	Unexpected starting of cutting means after power failure	5.4.2
10.6	Errors made by the operator (due to mismatch of machinery with human characteristics and abilities, see 8.6)	Feeding non-vegetable material	6.1; 6.2; annex D
		Removing guards before stopping the cutting means	5.2.4; 6.1; 6.2; annex D
13	<b>Failure of the power supply</b>	Unexpected start up of cutting means after power failure	5.4.2
14	<b>Failure of the control circuit</b>	Durability of interlock devices	5.2.3.1
15	<b>Errors of fitting</b>	Using the machine without guards or with guards fitted incorrectly	5.2.3.1; 6.1; annex D
16	<b>Break-up during operation</b>	Cutters breaking in use	5.9.4.2
17	<b>Falling or ejected objects or fluids</b>	Thrown objects from feed intake	5.9.2; 6.1; annex D
18	<b>Loss of stability / overturning of machinery</b>	Static stability	5.9.3
19	<b>Slip, trip and fall of persons</b> (related to machinery)	Operating position	6.1; annex D
Additional hazards, hazardous situations and hazardous events due to mobility			
24	<b>Due to the power source and to the transmission of power</b>		
24.1	Hazards from the engine and the batteries	Harm from battery vapours Spillage of battery and fluid containers	5.6.2.2; 5.7
		Battery overload	5.6.3
25	<b>From/to third persons</b>		
25.1	Unauthorised start-up/use	Unauthorised start up of battery start machines	5.4.2; 6.1; annex D
26	<b>Insufficient instructions for the driver/operator</b>	Unfamiliar or dangerous usage	6.1; annex D

## 5 Safety requirements and/or measures

### 5.1 General

The machine shall comply with the safety requirements and/or protective measures of this clause. In addition, the machine shall be designed according to the principles of EN ISO 12100 for hazards relevant but not significant, which are not dealt with by this document (e.g. sharp edges on the outside of the machine).

### 5.2 Access to power driven components

#### 5.2.1 Feed safety openings

##### 5.2.1.1 General

**A2** To safeguard against contact with the cutting means through the feed safety opening(s) the machine shall either:

- be constructed to meet the dimensional requirements given in 5.2.1.2 or 5.2.1.3 and Table 2, or
- if a straight rod of 1 m length and 12 mm diameter will not pass through the opening to contact the cutting means the tortuous path test of 5.2.1.4 shall apply.

Where a feed intake opening is divided into two or more feed safety openings, the device that creates the division shall be rigid and permanently attached to the feed intake opening. **A2**

##### 5.2.1.2 **A2** Dimensional requirements - Single feed safety openings

Where a safety opening is a slot, square or round the safety opening shall, as a minimum be in accordance with Table 2.

Where a feed safety opening is of an irregular shape, the size of opening shall be established by:

- a) determining:
  - the diameter of the smallest round opening and
  - the side of the smallest square opening and
  - the width of the narrowest slot opening

into which the irregular opening can be completely inserted (see EN ISO 13857:2008, Figure 3);

- b) selecting the corresponding three minimum safety distances according to Table 2.

The shortest safety distance of the three values selected according to b) may be used.

### Verification

The measured dimensions of the safety openings, as defined in this clause, and safety distances shall comply with Table 2. **A2**