



SLOVENSKI STANDARD
SIST EN 12463:2004+A1:2011
01-julij-2011

Nadomešča:
SIST EN 12463:2004

Stroji za predelavo hrane - Polnilniki in pomožni stroji - Varnostne in higienske zahteve (vključno z dopolnilom A1)

Food processing machinery - Filling machines and auxiliary machines - Safety and hygiene requirements

Nahrungsmittelmaschinen - Füllmaschinen und Vorsatzmaschinen - Sicherheits- und Hygieneanforderungen

Machines pour les produits alimentaires - Machines à pousser et machines auxiliaires - Prescriptions relatives à la sécurité et à l'hygiène

Ta slovenski standard je istoveten z: EN 12463:2004+A1:2011

ICS:

67.260

Tovarne in oprema za
živilsko industrijo

Plants and equipment for the
food industry

SIST EN 12463:2004+A1:2011

en,fr,de

iTeh STANDARD PREVIEW
(standards.iteh.ai)

SIST EN 12463:2004+A1:2011

<https://standards.iteh.ai/catalog/standards/sist/5ad3aac6-8849-4267-94a8-40a26fe54790/sist-en-12463-2004a1-2011>

EUROPEAN STANDARD
NORME EUROPÉENNE
EUROPÄISCHE NORM

EN 12463:2004+A1

February 2011

ICS 67.260

Supersedes EN 12463:2004

English Version

Food processing machinery - Filling machines and auxiliary machines - Safety and hygiene requirements

Machines pour les produits alimentaires - Machines à pousser et machines auxiliaires - Prescriptions relatives à la sécurité et à l'hygiène

Nahrungsmittelmaschinen - Füllmaschinen und Vorsatzmaschinen - Sicherheits- und Hygieneanforderungen

This European Standard was approved by CEN on 2 February 2004 and includes Amendment 1 approved by CEN on 18 Dezember 2010.

CEN members are bound to comply with the CEN/CENELEC Internal Regulations which stipulate the conditions for giving this European Standard the status of a national standard without any alteration. Up-to-date lists and bibliographical references concerning such national standards may be obtained on application to the CEN-CENELEC Management Centre or to any CEN member.

This European Standard exists in three official versions (English, French, German). A version in any other language made by translation under the responsibility of a CEN member into its own language and notified to the CEN-CENELEC Management Centre has the same status as the official versions.

CEN members are the national standards bodies of Austria, Belgium, Bulgaria, Croatia, Cyprus, Czech Republic, Denmark, Estonia, Finland, France, Germany, Greece, Hungary, Iceland, Ireland, Italy, Latvia, Lithuania, Luxembourg, Malta, Netherlands, Norway, Poland, Portugal, Romania, Slovakia, Slovenia, Spain, Sweden, Switzerland and United Kingdom.



[SIST EN 12463:2004+A1:2011](https://standards.iteh.ai/catalog/standards/sist/5ad3aac6-8849-4267-94a8-40a26fe54790/sist-en-12463-2004a1-2011)

<https://standards.iteh.ai/catalog/standards/sist/5ad3aac6-8849-4267-94a8-40a26fe54790/sist-en-12463-2004a1-2011>



EUROPEAN COMMITTEE FOR STANDARDIZATION
COMITÉ EUROPÉEN DE NORMALISATION
EUROPÄISCHES KOMITEE FÜR NORMUNG

Management Centre: Avenue Marnix 17, B-1000 Brussels

Contents	Page
Foreword.....	3
Introduction	4
1 Scope	5
2 Normative references	10
3 Terms and definitions	11
4 List of significant hazards	14
5 Safety and hygiene requirements and/or protective measures	21
6 Verification of safety and hygiene requirements and/or protective measures	45
7 Information for use	47
Annex A (normative) Noise test code for filling machines and auxiliary machines (grade 2)	51
A.1 Determination of the emission sound pressure level	51
A.2 Installation and mounting conditions	51
A.3 Operating conditions	51
A.4 Measurement	51
A.5 Information to be recorded	52
A.6 Information to be reported	52
A.7 Declaration and verification of the noise emission values	52
Annex B (normative) Design principles to ensure the cleanability of Filling machines and auxiliary machines	53
B.1 Definition	53
B.2 Materials of construction	54
B.3 Design	54
Annex C (normative) Common hazards for food processing machines and reduction requirements applicable to Filling machines and auxiliary machines	58
C.1 Cutting hazards	58
C.2 Risks from cleaning	58
C.3 External influences on electrical equipment	58
C.4 Hazards due to cleaning substances	58
C.5 Hazards from neglecting use of PPE	59
C.6 Hazard from noise	59
Annex ZA (informative)  Relationship between this European Standard and the Essential Requirements of EU Directive 2006/42/EC 	60
Bibliography	61

Foreword

This document (EN 12463:2004+A1:2011) has been prepared by Technical Committee CEN/TC 153 "Machinery intended for use with foodstuffs and feed", the secretariat of which is held by DIN.

This European Standard shall be given the status of a national standard, either by publication of an identical text or by endorsement, at the latest by August 2011, and conflicting national standards shall be withdrawn at the latest by August 2011.

Attention is drawn to the possibility that some of the elements of this document may be the subject of patent rights. CEN [and/or CENELEC] shall not be held responsible for identifying any or all such patent rights.

This document includes Amendment 1, approved by CEN on 2010-12-18.

This document supersedes EN 12463:2004.

The start and finish of text introduced or altered by amendment is indicated in the text by tags \square_{A1} \square_{A1} .

This document has been prepared under a mandate given to CEN by the European Commission and the European Free Trade Association and supports essential requirements of EU Directive(s).

For relationship with EU Directives, see informative Annex ZA, which is an integral part of this document.

It is one of a series of standards for meat processing machinery, in compliance with \square_{A1} EN 1672-2:2005+A1:2009 \square_{A1} , Annex C.

This European Standard also contains a bibliography.

According to the CEN/CENELEC Internal Regulations, the national standards organizations of the following countries are bound to implement this European Standard: Austria, Belgium, Bulgaria, Croatia, Cyprus, Czech Republic, Denmark, Estonia, Finland, France, Germany, Greece, Hungary, Iceland, Ireland, Italy, Latvia, Lithuania, Luxembourg, Malta, Netherlands, Norway, Poland, Portugal, Romania, Slovakia, Slovenia, Spain, Sweden, Switzerland and United Kingdom.

Introduction

A1 This document is a type C standard as stated in EN ISO 12100.

The machinery concerned and the extent to which hazards, hazardous situations and hazardous events are covered are indicated in the scope of this document.

When provisions of this type C standard are different from those which are stated in type A or B standards, the provisions of this type C standard take precedence over the provisions of the other standards, for machines that have been designed and built according to the provisions of this type C standard. **A1**

iTeh STANDARD PREVIEW (standards.iteh.ai)

[SIST EN 12463:2004+A1:2011](https://standards.iteh.ai/catalog/standards/sist/5ad3aac6-8849-4267-94a8-40a26fe54790/sist-en-12463-2004a1-2011)

<https://standards.iteh.ai/catalog/standards/sist/5ad3aac6-8849-4267-94a8-40a26fe54790/sist-en-12463-2004a1-2011>

1 Scope

1.1 This document applies for:

- filling machines with cylinder and piston,
- filling machines with feed intake hopper, feeder and loading device,
- auxiliary machines for filling machines.

This document does not apply to filling machines with cylinder and manual operation.

A1) This document deals with all significant hazards, hazardous situations and events relevant to machines, appliances and machinery, when they are used as intended and under the conditions foreseen by the manufacturer and also the reasonable foreseeable misuse (see Clause 4). **A1)**

These significant hazards, hazardous situations and events exist during the whole life of filling machines.

This document is not applicable to filling machines and auxiliary machines which are manufactured before the date of publication of this document by CEN.

Filling machines described in this document are no forming, filling and sealing machines as described in EN 415-3. Clipping machines are not covered by this document.

1.2 This document covers the following types of filling machines and auxiliary machines:

1.2.1 Filling machines with cylinder

- Filling machines with cylinder consist of piston, closing cover, machine frame accessory drive parts and electrical and hydraulic components.

- The material being processed will be fed by hand into the cylinder.

The distance H_1 from the floor (standing area) to the middle of the discharge port (filling horn) is > 975 mm (see Figure 1).

- Filling machines with cylinder will be switched on or off by a knee-operated lever switch.
- Filling machines with cylinder can be fitted with;
 - divider slide valve,
 - divider rotating valve.

1.2.2 Filling machines with feed intake hopper

- Filling machines with feed hopper intake (with or without infeed auger) consist of feeder on discharge side of the feed intake hopper, machine frame, accessory drive parts and electric, electronic or pneumatic components, depending on machine type.
- The material being processed will be fed by hand into the feeding hopper of the filling machine.
- Processing of larger quantities of filling material and the height of the filling machine with feed intake hopper can make it necessary to provide a loading device. The loading device is covered by this document.

EN 12463:2004+A1:2011 (E)

- The distance H1 from the floor (standing area) to the middle of the discharge port (filling horn) is > 975 mm (see Figure 2).
- Filling machines will be switched on or off by knee-operated lever switches or hand operated switches and/or remote control signals.
- Filling machines with feed intake hopper can be equipped with;
 - divider device,
 - cover or photoelectric guard at the mouth of the feed intake hopper,
 - pressure activated trip bar or light barrier at the hopper edge,
 - divided feed intake hopper,
 - plough or counter auger,
 - interlocked step or interlocked ladder,
 - two hand control at the mouth of the feed intake hopper,
 - loading device.

iTeh STANDARD PREVIEW
(standards.iteh.ai)

[SIST EN 12463:2004+A1:2011](https://standards.iteh.ai/catalog/standards/sist/5ad3aac6-8849-4267-94a8-40a26fe54790/sist-en-12463-2004a1-2011)

<https://standards.iteh.ai/catalog/standards/sist/5ad3aac6-8849-4267-94a8-40a26fe54790/sist-en-12463-2004a1-2011>

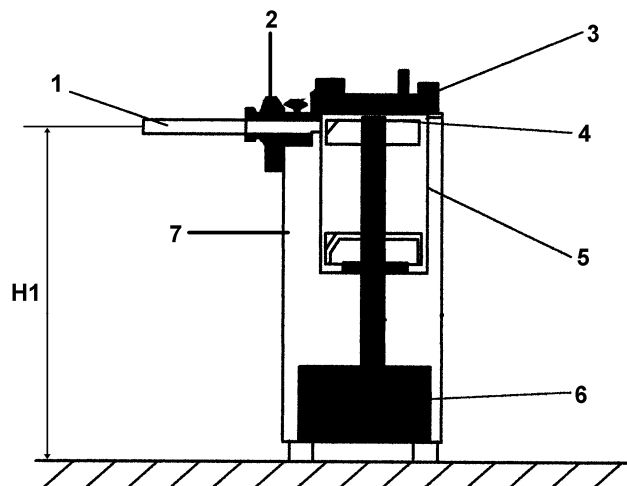
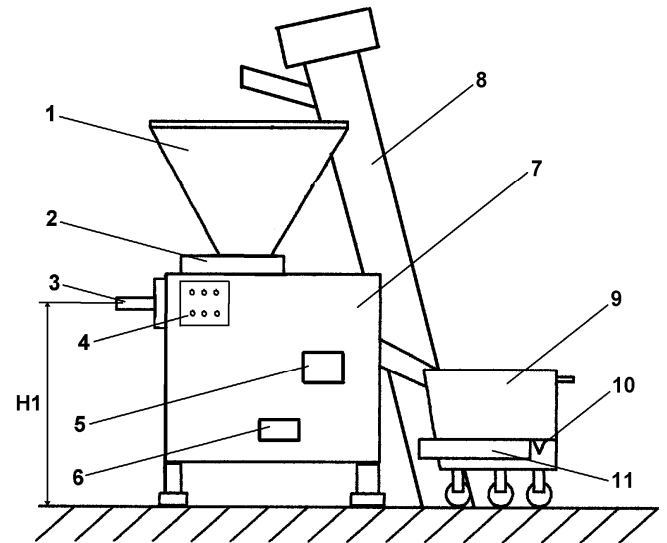
 $H_1 > 975 \text{ mm}$

 $H_1 > 975 \text{ mm}$
Key

- 1 filling horn
- 2 divider rotating valve/divider rotating valve
- 3 closing cover
- 4 piston
- 5 cylinder
- 6 drive mechanism
- 7 ON / OFF switch, hood

Key

- 1 feed intake hopper
- 2 feeder
- 3 filling horn
- 4 ON / OFF switch, hood
- 5 step, interlocked
- 6 intermediate step
- 7 drive mechanism
- 8 loading device
- 9 transport car
- 10 locking device
- 11 lifting device

Figure 1 — Assembly of a filling machine with piston

Figure 2 — Assembly of a filling machine with feed intake hopper and loading device

1.2.3 Auxiliary machines

- Auxiliary machines consist of devices for filling, portioning, twisting, displacing, forming, mincing and of a drive system.
- Auxiliary machines do not operate independently. These machines will be actuated directly or by filling machines (see Figures 3 to 9).
- Auxiliary machines will be switched on or off by knee operated lever switches or hand operated switches and/or remote control signals.
- Auxiliary machines can be fitted with;
 - dividing device,
 - hanging device.

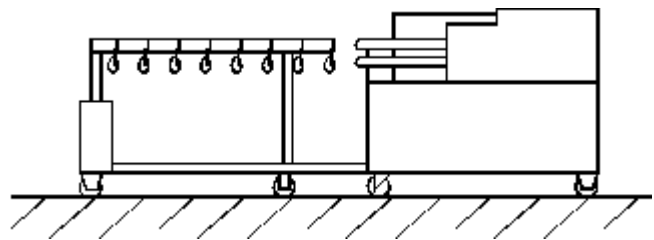
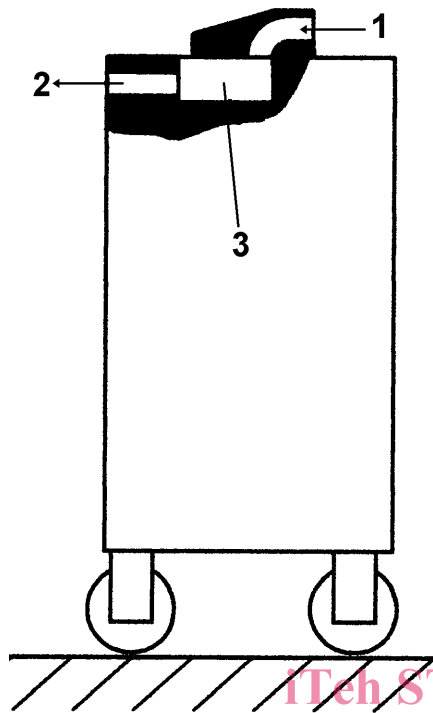

STANDARD PREVIEW
(standards.iteh.ai)

Key

- 1 inlet
- 2 outlet
- 3 feeder

[SIST EN 12463:2004+A1:2011
https://standards.iteh.ai/catalog/standards/sist/5ad3aac6-8849-4267-94a8-40a26fe54790/sist-en-12463-2004a1-2011](https://standards.iteh.ai/catalog/standards/sist/5ad3aac6-8849-4267-94a8-40a26fe54790/sist-en-12463-2004a1-2011)

Figure 3 — Auxiliary twisting machine

Figure 4 — Auxiliary portioning and hanging line

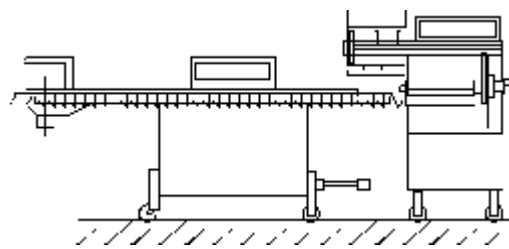
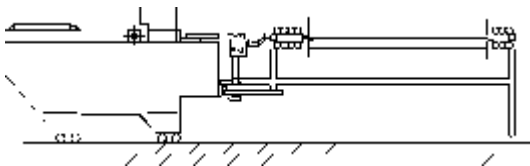
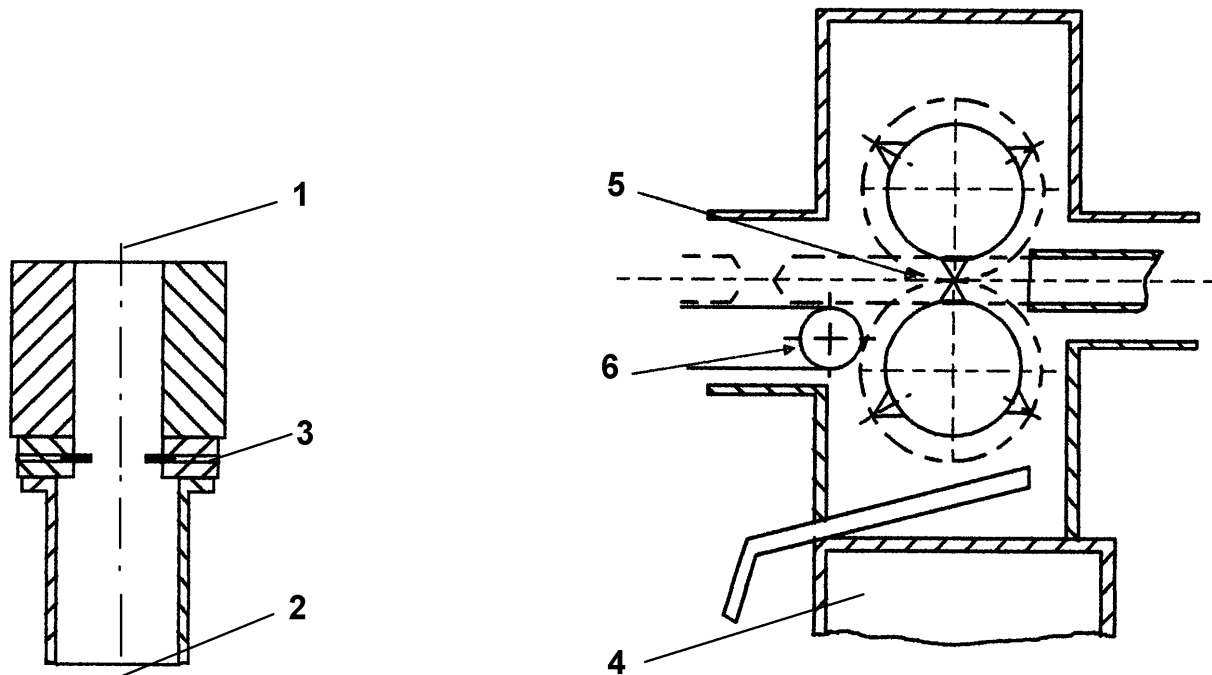

Figure 5 — Auxiliary portioning and hanging line

Figure 6 — Auxiliary portioning and hanging line

**Key**

- 1 inlet
- 2 outlet
- 3 forming device

iTeh STANDARD PREVIEW
(standards.iteh.ai)

- 4 base
- 5 forming device
- 6 conveyor belt

Figure 7 — Forming devices

SIST EN 12463:2004+A1:2011

<http://standards.iteh.ai/catalog/standards/sist/5ad3aac6-8849-4267-94a8-40a26154790/sist-en-12463-2004a1-2011>

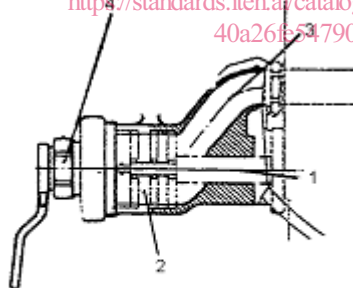
**Key**

- 1 drive shaft
- 2 set of cutting tools
- 3 feed intake canal
- 4 nut/plate

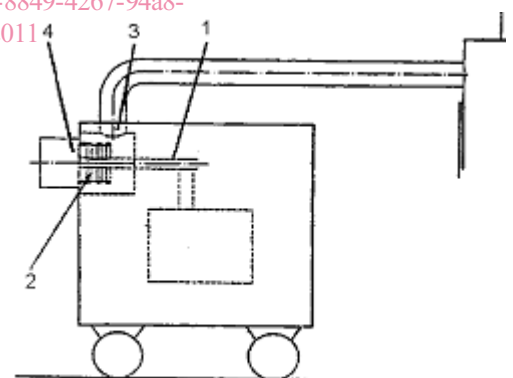
Figure 8 — Ancillary mincing machine driven by the filling machines**Key**

- 1 drive shaft
- 2 cutting tools
- 3 feed intake canal
- 4 locking/plate

Figure 9 — Ancillary mincing machine with direct drive**1.3 Intended use**

During the production of this document the following assumptions were made:

EN 12463:2004+A1:2011 (E)

Filling machines are installed in a sufficiently lighted place.

They are used only by designated and skilled operators.

Filling machines are not foreseen to be cleaned with pressurized water (e.g. tap water).

2 Normative references

The following referenced documents are indispensable for the application of this document. For dated references, only the edition cited applies. For undated references, the latest edition of the referenced document (including any amendments) applies.

A1 EN 574:1996+A1:2008, *Safety of machinery — Two-hand control devices — Functional aspects — Principles for design*

EN 614-1, *Safety of machinery — Ergonomic design principles — Part 1: Terminology and general principles*

EN 953:1997+A1:2009, *Safety of machinery — Guards — General requirements for the design and construction of fixed and movable guards*

EN 1005-1, *Safety of machinery — Human physical performance — Part 1: Terms and definitions*

EN 1005-2, *Safety of machinery — Human physical performance — Part 2: Manual handling of machinery and component parts of machinery*

EN 1005-3, *Safety of machinery — Human physical performance — Part 3: Recommended force limits for machinery operation*

EN 1088:1995+A2:2008, *Safety of machinery — Interlocking devices associated with guards — Principles for design and selection*

EN 1672-2:2005+A1:2009, *Food processing machinery — Basic concepts — Part 2: Hygiene requirements*

EN 13288:2005+A1:2009, *Food processing machinery — Bowl lifting and tilting machines — Safety and hygiene requirements*

EN 60204-1:2006, *Safety of machinery — Electrical equipment of machines — Part 1: General requirements (IEC 60204-1:2005, modified)*

EN 60529, *Degrees of protection provided by enclosures (IP code) (IEC 60529:1989)*

EN 61496-1, *Safety of machinery — Electro-sensitive protective equipment — Part 1: General requirements and tests (IEC 61496-1:2004, modified)*

EN ISO 3744:2010, *Acoustics — Determination of sound power levels and sound energy levels of noise sources using sound pressure — Engineering methods for an essentially free field over a reflecting plane (ISO 3744:2010)*

EN ISO 4287, *Geometrical product specifications (GPS) — Surface texture: Profile method — Terms, definitions and surface texture parameters (ISO 4287:1997)*

EN ISO 4871:2009, *Acoustics — Declaration and verification of noise emission values of machinery and equipment (ISO 4871:1996)*

EN ISO 11201:2010, *Acoustics — Noise emitted by machinery and equipment — Determination of emission sound pressure levels at a work station and at other specified positions in an essentially free field over a reflecting plane with negligible environmental corrections (ISO 11201:2010)*

EN ISO 11688-1, *Acoustics — Recommended practice for the design of low-noise machinery and equipment — Part 1: Planning (ISO/TR 11688-1:1995)*

EN ISO 12100:2010, *Safety of machinery — General principles for design — Risk assessment and risk reduction (ISO 12100:2010)*

EN ISO 13849-1:2008, *Safety of machinery — Safety-related parts of control systems — Part 1: General principles for design (ISO 13849-1:2006)*

EN ISO 13855, *Safety of machinery — Positioning of safeguards with respect to the approach speeds of parts of the human body (ISO 13855:2010)*

EN ISO 13857:2008, *Safety of machinery — Safety distances to prevent hazard zones being reached by upper and lower limbs (ISO 13857:2008)* ^{A1}

3 Terms and definitions

^{A1} For the purposes of this document, the terms and definitions given in EN ISO 12100:2010 and the following apply. ^{A1}

3.1 twisting device

device to separate one portion from the next by twisting

3.2 divider rotating valve

rotatable closing component

3.3 divider device

divider rotating valve, a divider slide valve

3.4 divider slide valve

movable closing plate

3.5 hanger device

device to suspend or transport the product

3.6 hanger

movable unit to convey the product onto a hanger device

3.7 ejector/extractor

device for detaching the set of cutting tools and the worm

3.8 extraction claw

tool for detaching the set of cutting tools and the worm

iTeh STANDARD PREVIEW
(standards.iteh.ai)

SIST EN 12463:2004+A1:2011

<https://standards.iteh.ai/catalog/standards/sist/5ad3aac6-8849-4267-94a8-40a26fe54790/sist-en-12463-2004a1-2011>

EN 12463:2004+A1:2011 (E)

- 3.9
design height**
height of the feed intake hopper edge measured from the floor
- 3.10
loading device**
lift-tilt device for lifting and tilting of transport cars or containers
- 3.11
casing brake**
device for retaining and braking the product casing on the filling horn
- 3.12
casing holding device**
device for holding and sealing product casings onto or in connection with the filling horn
- 3.13
casing clamp**
device for centring and clamping the shirred product casing
- 3.14
feed intake hopper**
container for receiving products to be processed with safety function
- 3.15
locking device**
device for locking the transport car or container in the loading device
- 3.16
feeder**
unit for product transport
- 3.17
plough**
fixed curve-shaped counter-component to the infeed auger
- 3.18
divided hopper**
feed intake hopper with a disconnecting point in the upper hopper part
- 3.19
protecting device against tilting**
device to prevent lifting or toppling over of the machine
- 3.20
design dimension**
sum of dimensions measured from the floor (standing area), in the case of steps, intermediate steps or ladders from the standing area to the feed intake hopper edge and from the feed intake hopper edge to the first danger point in the feed intake hopper
- 3.21
piston**
moving part for pressing out the product
- 3.22
light barrier**
optical-electric safety component

iTeh STANDARD PREVIEW
(standards.iteh.ai)

[SIST EN 12463:2004+A1:2011](https://standards.iteh.ai/catalog/standards/sist/5ad3aac6-8849-4267-94a8-40a26fe54790/sist-en-12463-2004a1-2011)

<https://standards.iteh.ai/catalog/standards/sist/5ad3aac6-8849-4267-94a8-40a26fe54790/sist-en-12463-2004a1-2011>

3.23**blade**

cutting tool with one or several blades

3.24**rotating head**

hinged installation with one or more filling horns

3.25**trip bar**

movable device with safety function

3.26**worm casing**

casing for holding the worm and the set of cutting tools

3.27**set of cutting tools**

rough-cutter, blade and hole plate for size reduction of product

3.28**protective hood**

movable safety device on the discharge outlet

3.29**hinged arm**

movable part of the lift-tilt device

3.30**counter auger**

fixed counter-component to the infeed auger

3.31**transport car**

mobile device for holding the processed or to the processed product

3.32**cutting device**

device (e.g. knife, wire, scissor) for the cutting of portions filled into product casings

3.33**overtravelling guard**

device for automatic movement stopping

3.34**removal**

device for removing the product in the product casing

3.35**closing Cover**

closing plate with safety function at the opening of the cylinder

3.36**lock nut**

device for locking the set of cutting tools in the cutting chamber

3.37**infeed auger**

rotating conveying element in the feed intake hopper

iTeh STANDARD PREVIEW
(standards.iteh.ai)

SIST EN 12463:2004+A1:2011

<https://standards.iteh.ai/catalog/standards/sist/5ad3aac6-8849-4267-94a8-40a26fe54790/sist-en-12463-2004a1-2011>