



SLOVENSKI STANDARD

SIST EN 14706:2013

01-marec-2013

Nadomešča:
SIST EN 14706:2006

Toplotnoizolacijski proizvodi za opremo stavb in industrijske inštalacije - Ugotavljanje najvišje temperature servisiranja

Thermal insulating products for building equipment and industrial installations -
Determination of maximum service temperature

Wärmedämmstoffe für die Haustechnik und für betriebstechnische Anlagen -
Bestimmung der oberen Anwendungsgrenztemperatur

Produits isolants thermiques pour l'équipement du bâtiment et les installations
industrielles - Détermination de la température maximale de service

Ta slovenski standard je istoveten z: **EN 14706:2012**

ICS:

91.100.60	Materiali za toplotno in zvočno izolacijo	Thermal and sound insulating materials
-----------	--	---

SIST EN 14706:2013

en,fr,de

iTeh STANDARD PREVIEW
(standards.iteh.ai)

SIST EN 14706:2013

<https://standards.iteh.ai/catalog/standards/sist/ba43791f-d6f9-4d9a-8c96-0320b34fb18a/sist-en-14706-2013>

EUROPEAN STANDARD

EN 14706

NORME EUROPÉENNE

EUROPÄISCHE NORM

October 2012

ICS 91.100.60

Supersedes EN 14706:2005

English Version

Thermal insulating products for building equipment and industrial installations - Determination of maximum service temperature

Produits isolants thermiques pour l'équipement du bâtiment et les installations industrielles - Détermination de la température maximale de service

Wärmedämmstoffe für die Haustechnik und für betriebstechnische Anlagen - Bestimmung der oberen Anwendungsgrenztemperatur

This European Standard was approved by CEN on 24 August 2012.

CEN members are bound to comply with the CEN/CENELEC Internal Regulations which stipulate the conditions for giving this European Standard the status of a national standard without any alteration. Up-to-date lists and bibliographical references concerning such national standards may be obtained on application to the CEN-CENELEC Management Centre or to any CEN member.

This European Standard exists in three official versions (English, French, German). A version in any other language made by translation under the responsibility of a CEN member into its own language and notified to the CEN-CENELEC Management Centre has the same status as the official versions.

CEN members are the national standards bodies of Austria, Belgium, Bulgaria, Croatia, Cyprus, Czech Republic, Denmark, Estonia, Finland, Former Yugoslav Republic of Macedonia, France, Germany, Greece, Hungary, Iceland, Ireland, Italy, Latvia, Lithuania, Luxembourg, Malta, Netherlands, Norway, Poland, Portugal, Romania, Slovakia, Slovenia, Spain, Sweden, Switzerland, Turkey and United Kingdom.

[SIST EN 14706:2013](https://standards.iteh.ai/catalog/standards/sist/ba43791f-d6f9-4d9a-8c96-0320b34fb18a/sist-en-14706-2013)

<https://standards.iteh.ai/catalog/standards/sist/ba43791f-d6f9-4d9a-8c96-0320b34fb18a/sist-en-14706-2013>



EUROPEAN COMMITTEE FOR STANDARDIZATION
COMITÉ EUROPÉEN DE NORMALISATION
EUROPÄISCHES KOMITEE FÜR NORMUNG

Management Centre: Avenue Marnix 17, B-1000 Brussels

Contents

	Page
Foreword.....	4
1 Scope	5
2 Normative references	5
3 Terms and definitions	5
4 Principle.....	5
5 Apparatus	6
6 Test specimens	7
6.1 Dimensions of test specimens	7
6.2 Number of test specimens	7
6.3 Conditioning of test specimens	8
7 Procedure	8
7.1 Test conditions	8
7.2 Test procedure	8
8 Calculation and expression of results.....	9
8.1 Thickness deformation versus time	9
8.2 Dimensional changes	9
8.3 Additional tests and/or observations	10
8.4 Internal self heating	10
9 Accuracy of measurement.....	11
10 Test report	12
Annex A (normative) Modifications of and additions to the general test method for mineral wool products.....	13
A.1 General.....	13
A.2 Test specimens	13
A.2.1 Conditioning of test specimens	13
A.2.2 Dimensions of test specimens	13
A.3 Procedure	13
A.3.1 Test conditions	13
A.3.2 Test procedure	13
A.4 Additional tests and/or observations	14
A.5 Test for internal self-heating	14
Annex B (normative) Modifications of and additions to the general test method for cellular glass products.....	16
B.1 General.....	16
B.2 Apparatus	16
B.3 Test specimens	16
B.3.1 Conditioning of test specimens	16
B.3.2 Dimensions of test specimens	16
B.4 Test procedure	16
B.5 Additional tests and/or observations	16
B.5.1 Observations	16
B.5.2 Additional tests	16
Annex C (normative) Modifications of and additions to the general test method for phenolic foam products.....	17
C.1 General.....	17
C.2 Test specimens	17
C.2.1 Dimensions of test specimens	17

C.2.2	Conditioning of test specimens	17
C.3	Test procedure.....	17
C.4	Additional tests and/or observations	17
Annex D	(normative) Modifications of and additions to the general test method for polyethylene foam (PEF) and flexible elastomeric foam (FEF) products	19
D.1	General	19
D.2	Apparatus	19
D.3	Dimensions of the test specimens	19
D.4	Test procedure.....	19
D.5	Calculation and expression of results	20
	Bibliography.....	21

iTeh STANDARD PREVIEW (standards.iteh.ai)

[SIST EN 14706:2013](https://standards.iteh.ai/catalog/standards/sist/ba43791f-d6f9-4d9a-8c96-0320b34fb18a/sist-en-14706-2013)

<https://standards.iteh.ai/catalog/standards/sist/ba43791f-d6f9-4d9a-8c96-0320b34fb18a/sist-en-14706-2013>

Foreword

This document (EN 14706:2012) has been prepared by Technical Committee CEN/TC 88 "Thermal insulating materials and products", the secretariat of which is held by DIN.

This European Standard shall be given the status of a national standard, either by publication of an identical text or by endorsement, at the latest by April 2013, and conflicting national standards shall be withdrawn at the latest by April 2013.

Attention is drawn to the possibility that some of the elements of this document may be the subject of patent rights. CEN [and/or CENELEC] shall not be held responsible for identifying any or all such patent rights.

This document supersedes EN 14706:2005.

The main technical changes that have been made in this new edition of EN 14706 are the following:

- a) Normative references have been updated;
- b) Figure 1 has been corrected;
- c) Clause 9, Accuracy of measurements has been revised;
- d) 5.1, Flat square or circular hot plate has been supplemented;
- e) 6.1, Dimensions of test specimens has been revised;
- f) A.3.1, Test conditions has been revised; [SIST EN 14706:2013](https://standards.iteh.ai/catalog/standards/sist/ba43791f-d6f9-4d9a-8c96-0320b34f-18a/sist-en-14706-2013)
- g) A.5, Test for internal self-heating has been completed, <https://standards.iteh.ai/catalog/standards/sist/ba43791f-d6f9-4d9a-8c96-0320b34f-18a/sist-en-14706-2013>
- h) C.4, Additional tests and/or observations has been completed;
- i) D.3, Dimensions of test specimens has been revised.

This European Standard is one of a series of standards which specify test methods for determining dimensions and properties of thermal insulating materials and products. It supports a series of product standards for thermal insulating materials and products which derive from the Council Directive of 21 December 1988 on the approximation of laws, regulations and administrative provisions of the Member States relating to construction products (Directive 89/106/EEC) through the consideration of the essential requirements.

This European Standard has been prepared for products used to insulate building equipment and industrial installations, but it may also be applied to products used in other areas.

A similar standard is available for testing of preformed pipe insulation EN 14707, *Thermal insulating products for building equipment and industrial installations — Determination of maximum service temperature for preformed pipe insulation*.

According to the CEN/CENELEC Internal Regulations, the national standards organisations of the following countries are bound to implement this European Standard: Austria, Belgium, Bulgaria, Croatia, Cyprus, Czech Republic, Denmark, Estonia, Finland, Former Yugoslav Republic of Macedonia, France, Germany, Greece, Hungary, Iceland, Ireland, Italy, Latvia, Lithuania, Luxembourg, Malta, Netherlands, Norway, Poland, Portugal, Romania, Slovakia, Slovenia, Spain, Sweden, Switzerland, Turkey and the United Kingdom.

1 Scope

This European Standard specifies the equipment and procedures for determining the maximum service temperature of flat insulation products. It is applicable to thermal insulating products.

2 Normative references

The following documents, in whole or in part, are normatively referenced in this document and are indispensable for its application. For dated references, only the edition cited applies. For undated references, the latest edition of the referenced document (including any amendments) applies.

EN 823, *Thermal insulating products for building applications — Determination of thickness*

EN 12085, *Thermal insulating products for building applications — Determination of linear dimensions of test specimens*

EN 12429, *Thermal insulating products for building applications — Conditioning to moisture equilibrium under specified temperature and humidity conditions*

EN 14303, *Thermal insulation products for building equipment and industrial installations — Factory made mineral wool (MW) products - Specification*

ISO 5725-2:1994, *Accuracy (trueness and precision) of measurement methods and results — Part 2: Basic method for the determination of repeatability and reproducibility of a standard measurement method*

ISO 7884-1, *Glass — Viscosity and viscometric fixed points — Part 1: Principles for determining viscosity and viscometric fixed points*

ISO 7884-7, *Glass — Viscosity and viscometric fixed points — Part 7: Determination of annealing point and strain point by beam bending*

iTeh STANDARD PREVIEW
(standards.iteh.ai)
SIST EN 14706:2013
<https://standards.iteh.ai/catalog/standards/sist/ba43791f-d6f9-4d9a-8c96-0320b34fb18a/sist-en-14706-2013>

3 Terms and definitions

For the purposes of this document, the following terms and definitions apply.

3.1

maximum service temperature

highest temperature at which the insulation product, when installed at the recommended thickness in a given application, continues to function within specified limits of performance

[SOURCE: EN ISO 9229:2007, 2.6.9.1]

Note 1 to entry: The required performance may be in the areas of dimensional stability, thermal properties, and mechanical properties as well as changes in appearance and resistance against creation of hazards such as internal self heating (see Annexes A and C and possible requirements in the relevant product standard).

Note 2 to entry: In the present test procedure, which is used as a reference, the test specimen is exposed to a temperature difference going from ambient to the maximum service temperature. This may not reflect the actual application conditions when products are exposed to different temperatures on the two main faces, e.g. in multilayer systems or for faced products where the facing may limit the maximum service temperature.

4 Principle

Measure thickness, length, and width after one sided heat treatment for a specified time period, at the maximum service temperature, achieved using a specified rate of temperature increase. The thickness of the test specimen is measured during heat treatment, and the length and width only after cooling to ambient temperature.

The procedure may be an iterative process.

EN 14706:2012 (E)

Additional requirements for assessing the maximum service temperature of specific materials are described in normative annexes to this European Standard or the relevant product standard or any other European Technical Specification.

5 Apparatus

A general arrangement of the apparatus is indicated in Figure 1 and comprises:

5.1 Flat square or circular hot plate, with a uniform temperature distribution in the measuring zone on the hot face and a heat flux perpendicular to the face of the hot plate.

The deviation from flatness of the hot plate shall not exceed 1 mm in the measuring zone at ambient temperature.

The hot plate shall be capable of being controlled to within $\pm 2\%$ of a predetermined temperature or $\pm 10\text{ }^{\circ}\text{C}$, whichever is smaller.

The hot plate shall be capable of being heated at $50\text{ }^{\circ}\text{C/h}$ and/or $300\text{ }^{\circ}\text{C/h}$.

If a small size equipment (e.g. $\text{Ø } 100\text{ mm}$) is used, the free movement of the test specimen during the test is critical and shall be controlled strictly.

5.2 Edge insulation, with a gap as small as possible (e.g. $\leq 1\text{ mm}/100\text{ mm}$ test specimen size) which will permit free movement during the test of the test specimen and of the pressure plate.

5.3 Square or circular pressure plate, with the same dimensions as the test specimen exerting the required load on the test specimen.

5.4 Device, e.g. electromechanical, for measuring the thickness of the test specimen during the test to the nearest 0,1 mm.

<https://standards.iteh.ai/catalog/standards/sist/ba43791f-d6f9-4d9a-8c96-03e000000000/sist-en-14706-2013>

When determining the thickness of the test specimen, the thermal movement of the apparatus (e.g. quartz rod) shall be taken into account up to the maximum service temperature.

5.5 Temperature sensors (e.g. thermocouples) capable of recording the hot plate temperature to the nearest $\pm 1\%$ in centigrade but not less than $\pm 1\text{ }^{\circ}\text{C}$, which are placed within grooves on the hot plate.

Dimensions in millimetres

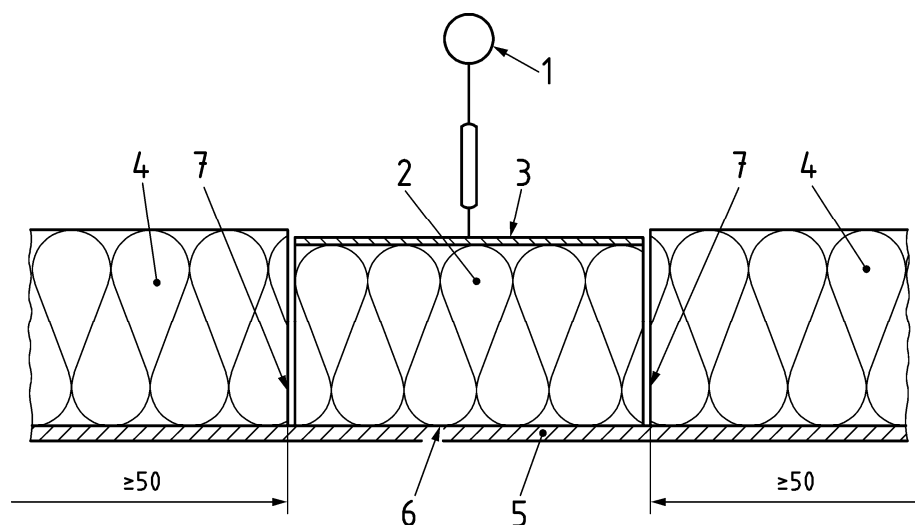
**Key**

- | | | | |
|---|---|---|--------------|
| 1 | device for measuring thickness, e.g. electromechanical device | 5 | hot plate |
| 2 | test specimen | 6 | thermocouple |
| 3 | pressure plate | 7 | small gap |
| 4 | edge insulation | | |

iTeh STANDARD PREVIEW

Figure 1 — Example of an apparatus for determining maximum service temperature

6 Test specimens

SIST EN 14706:2013

<https://standards.iteh.ai/catalog/standards/sist/ba43791f-d6f9-4d9a-8c96-0520b34fb18a/sist-en-14706-2013>

6.1 Dimensions of test specimens

a) **Length and width:** Test specimens shall be cut as squares or cylinders (as appropriate) and the cross section dimensions shall be as follows:

- 1) 100 mm × 100 mm (or diameter 100 mm) or
- 2) 150 mm × 150 mm (or diameter 150 mm) or
- 3) 200 mm × 200 mm (or diameter 200 mm) or
- 4) 300 mm × 300 mm (or diameter 300 mm).

The length and width or diameter shall be as specified in the relevant product standard or in annexes to this European Standard.

b) **Thickness:** The test specimen thickness shall be (100 ± 5) mm prepared by slicing if needed.

In the absence of a product standard or any other European Technical Specification the dimensions may be agreed between parties.

Testing may be performed on multilayer systems to simulate the conditions existing in the application.

6.2 Number of test specimens

The number of test specimens shall be as specified in the relevant product standard. If the number is not specified, then at least three test specimens shall be used.

EN 14706:2012 (E)

In the absence of a product standard or any other European Technical Specification the number of test specimens may be agreed between parties.

6.3 Conditioning of test specimens

The test specimens shall be stored for at least 6 h at (23 ± 5) °C. In case of dispute they shall be stored at (23 ± 2) °C and (50 ± 5) % relative humidity for the time specified in the relevant product standard or at least 24 h.

7 Procedure**7.1 Test conditions**

The initial temperature of the test specimen and the hot plate shall be (23 ± 5) °C.

7.2 Test procedure

Measure the length and width of the test specimen, l_1 , b_1 , (or diameter) in accordance with EN 12085, read to the nearest 0,5 mm.

Measure the thickness of the test specimen, d_0 , in accordance with EN 823 using the load specified in the relevant product standard.

Install the test specimen in the apparatus ensuring contact between the test specimen and the hot plate.

Load the test specimen with a pressure of 500 Pa and record the thickness, d_1 , to the nearest 0,1 mm.

For polyethylene foam and flexible elastomeric foam products, see Annex D.

Heat the test specimen using a temperature rate of increase of 50 °C/h or 300 °C/h, as specified in the relevant product standard or annex of this European Standard.

Maintain the temperature of the hot side, at the expected maximum service temperature, for 72 hours within ± 2 % of this temperature or ± 10 °C, whichever is smaller.

Record the thickness continuously during the test and at the end of the 72 h period, d_2 , to the nearest 0,1 mm.

Cool the test specimen in the equipment, to a temperature of < 35 °C and remeasure the thickness, d_3 , to the nearest 0,1 mm, unless otherwise specified in the relevant product standard or annex of this European Standard.

Take the test specimen from the apparatus and re-measure the length, l_2 , and the width, b_2 , (or diameter) of the test specimen as before to the nearest 0,5 mm.

In the case of non-rectangular edges, this shall be taken into account when measuring l_2 and b_2 (or diameter).

Examine the test specimen visually and note any changes caused by the test.

If the relevant product standard or annex of this European Standard specifies additional requirements, the observations and/or tests shall be performed accordingly.

Repeat the test procedure for the other test specimens.

8 Calculation and expression of results

8.1 Thickness deformation versus time

The curves thickness deformation versus time and temperature versus time recorded during testing shall be given. An example is shown in Figure 2.

8.2 Dimensional changes

Calculate the dimensional changes of thickness, $\Delta\varepsilon_d$, length, $\Delta\varepsilon_l$, and width, $\Delta\varepsilon_b$, in percentage, using the following formulae:

$$\Delta\varepsilon_d = 100 \times \frac{d_{2(\text{or } 3)} - d_1}{d_1} \quad (1)$$

$$\Delta\varepsilon_l = 100 \times \frac{l_2 - l_1}{d_1} \quad (2)$$

$$\Delta\varepsilon_b = 100 \times \frac{b_2 - b_1}{b_1} \quad (3)$$

where:

- d_1 is the measured thickness installed before heating, in millimetres;
- d_2 is the measured thickness installed after the 72 h at constant temperature, in millimetres;
- d_3 is the measured thickness after cooling down to a temperature of < 35 °C, in millimetres;
- l_1, b_1 are the measured length and width before heating, in millimetres;
- l_2, b_2 are the measured length and width after the 72 h at constant temperature and after cooling down, in millimetres.

In case of circular test specimens, the diameter/diameter change is calculated instead of length and width. Formula (2) can be used by inserting diameter instead of length.

If the dimensional change in thickness is larger by using d_3 instead of d_2 in Formula (1), this thickness shall be used in the calculation of the test result.

Calculate the test result as the mean values of dimensional changes, $\overline{\Delta\varepsilon_d}$, $\overline{\Delta\varepsilon_l}$, $\overline{\Delta\varepsilon_b}$, as a percentage rounded to the nearest 0,5 % from the test results of the individual test specimens.

If the change in the mean value (test result) for any of the dimensions exceeds the value specified in the relevant product standard, the test shall be repeated at a lower temperature until the dimensional changes are smaller than or equal to the specified value. This temperature is then considered as the maximum service temperature (see Figure 3), providing that the requirements given in 8.3 and 8.4 are also fulfilled.

The steps in centigrade for the indication of the maximum service temperature shall be as specified in the relevant product standard or annex to this European Standard. If the steps are not specified, the maximum service temperature shall be declared in steps of not less than 5 °C for temperatures up to 100 °C and in steps of not less than 10 °C for temperatures above 100 °C.

NOTE Results may not be comparable for a product tested at different thicknesses and/or different loads.