



Standard Practice for Design of High-Density Polyethylene (HDPE) Manholes for Subsurface Applications¹

This standard is issued under the fixed designation F1759; the number immediately following the designation indicates the year of original adoption or, in the case of revision, the year of last revision. A number in parentheses indicates the year of last reapproval. A superscript epsilon (ϵ) indicates an editorial change since the last revision or reapproval.

1. Scope

1.1 This practice covers general and basic procedures related to the design of manholes and components manufactured from high-density polyethylene (HDPE) for use in subsurface applications and applies to personnel access structures. The practice covers the material, the structural design requirements of the manhole barrel (also called vertical riser or shaft), floor (bottom), and top, and joints between shaft sections.

1.2 This practice offers the minimum requirements for the proper design of an HDPE manhole. Due to the variability in manhole height, diameter, and the soil, each manhole must be designed and detailed individually. When properly used and implemented, this practice can help ensure a safe and reliable structure for the industry.

1.3 *Disclaimer*—The reader is cautioned that independent professional judgment must be exercised when data or recommendations set forth in this practice are applied. The publication of the material contained herein is not intended as a representation or warranty on the part of ASTM that this information is suitable for general or particular use, or freedom from infringement of any patent or patents. Anyone making use of this information assumes all liability arising from such use. The design of structures is within the scope of expertise of a licensed architect, structural engineer, or other licensed professional for the application of principles to a particular structure.

1.4 The values stated in inch-pound units are to be regarded as the standard. The SI units given in parentheses are provided for information only.

1.5 *This standard does not purport to address all of the safety concerns, if any, associated with its use. It is the responsibility of the user of this standard to establish appropriate safety and health practices and determine the applicability of regulatory limitations prior to use.*

¹ This practice is under the jurisdiction of ASTM Committee F17 on Plastic Piping Systems and is the direct responsibility of Subcommittee F17.26 on Olefin Based Pipe.

Current edition approved Sept. 1, 2004. Published September 2004. Originally approved in 1997. Last previous edition approved in 1997 as F1759 - 97. DOI: 10.1520/F1759-97R04.

2. Referenced Documents

2.1 ASTM Standards:²

- D653 Terminology Relating to Soil, Rock, and Contained Fluids
- D1600 Terminology for Abbreviated Terms Relating to Plastics
- D2321 Practice for Underground Installation of Thermoplastic Pipe for Sewers and Other Gravity-Flow Applications
- D2657 Practice for Heat Fusion Joining of Polyolefin Pipe and Fittings
- D2837 Test Method for Obtaining Hydrostatic Design Basis for Thermoplastic Pipe Materials or Pressure Design Basis for Thermoplastic Pipe Products
- D3035 Specification for Polyethylene (PE) Plastic Pipe (DR-PR) Based on Controlled Outside Diameter
- D3212 Specification for Joints for Drain and Sewer Plastic Pipes Using Flexible Elastomeric Seals
- D3350 Specification for Polyethylene Plastics Pipe and Fittings Materials
- F412 Terminology Relating to Plastic Piping Systems
- F477 Specification for Elastomeric Seals (Gaskets) for Joining Plastic Pipe
- F714 Specification for Polyethylene (PE) Plastic Pipe (SDR-PR) Based on Outside Diameter
- F894 Specification for Polyethylene (PE) Large Diameter Profile Wall Sewer and Drain Pipe

3. Terminology

3.1 Definitions:

3.1.1 Definitions used in this practice are in accordance with Terminology F412 and Terminology D1600 unless otherwise indicated.

3.2 Definitions of Terms Specific to This Standard:

² For referenced ASTM standards, visit the ASTM website, www.astm.org, or contact ASTM Customer Service at service@astm.org. For *Annual Book of ASTM Standards* volume information, refer to the standard's Document Summary page on the ASTM website.

3.2.1 *anchor connection ring*—an HDPE ring attached to the manhole riser on which to place an antifoatation device, such as a concrete anchor ring.

3.2.2 *arching*—mobilization of internal shear resistance within a soil mass that results in a change in soil pressure acting on an underground structure.

3.2.3 *benching*—the internal floor of a manhole when it is elevated above the manhole invert, usually provided as a place for personnel to stand.

3.2.4 *closed profile*—a manhole barrel construction that presents an essentially smooth internal surface braced with projections or ribs, which are joined by an essentially smooth outer wall. Solid wall construction is considered a special case of the closed profile.

3.2.5 *downdrag*—downward shear force acting on the shaft's external surface and resulting from settlement of the manhole backfill.

3.2.6 *extrusion welding*—a joining technique that is accomplished by extruding a molten polyethylene bead between two prepared surface ends.

3.2.7 *floor*—the lowest internal surface of the manhole. The floor and bottom are often the same.

3.2.8 *inlet/outlet*—pipe (conduit) passing through the wall of the manhole.

3.2.9 *invert*—the flow channel in the floor of a manhole. This may consist of the lower half of a pipe, thus the name "invert".

3.2.10 *manhole*—an underground service access structure, which can access pipelines, conduits, or subsurface equipment.

3.2.11 *manhole bottom*—the lowest external surface of the manhole.

3.2.12 *manhole cone*—the top portion of the manhole through which entrance to the manhole is made and where the diameter may increase from the entrance way to the larger manhole barrel. Sometimes referred to as the *manway reducer*.

3.2.13 *open profile*—a manhole barrel construction that presents an essentially smooth internal surface with a ribbed or corrugated external surface. Open profile barrel constructions are normally *not* used for manholes.

3.2.14 *performance limits*—mechanisms by which the function of a structure may become impaired.

3.2.15 *riser*—the vertical barrel or "shaft" section of a manhole.

3.3 See Fig. 1 for illustration of manhole terminology.

4. Significance and Use

4.1 *Uses*—The requirements of this practice are intended to provide manholes suitable for installation in pipeline or conduit trenches, landfill perimeters, and landfills with limited settlement characteristics. Direct installation in sanitary landfills or other fills subject to large (in excess of 10 %) soil settlements may require special designs outside the scope of this practice.

4.1.1 Manholes are assumed to be subject to gravity flow only.

4.2 *Design Assumption*—The design methodology in this practice applies only to manholes that are installed in backfill consisting of Class I, Class II, or Class III material as defined in Practice D2321, which has been compacted to a minimum of 90 % standard proctor density. The designs are based on the

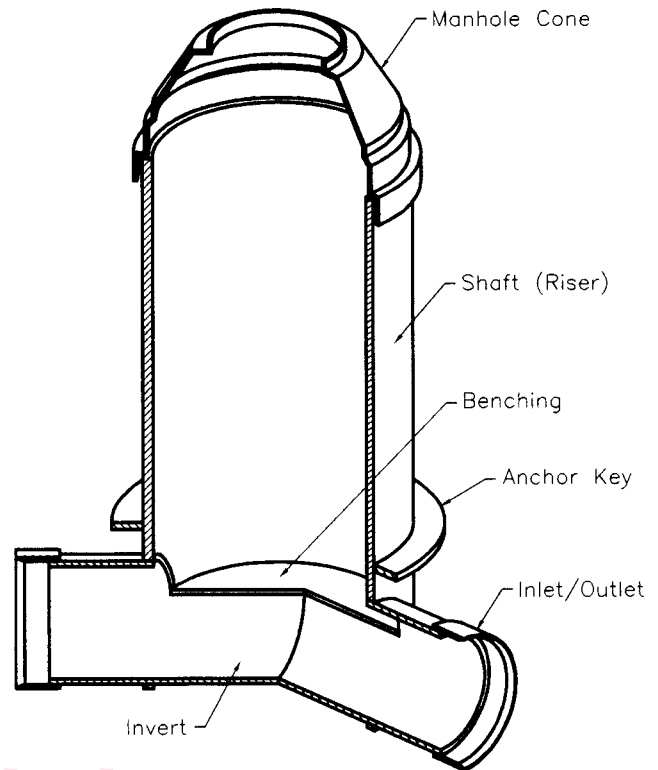

FIG. 1 Manhole Terminology

backfill extending at least 3.5 ft (1 m) from the perimeter of the manhole for the full height of the manhole and extending laterally to undisturbed in situ soil. Manholes are assumed placed on a stable base consisting of at least 12 in. (30.5 cm) of Class I material compacted to at least 95 % standard proctor density or a concrete slab. The foundation soils under the base must provide adequate bearing strength to carry downdrag loads.

4.2.1 Manholes installed in sanitary landfills or other fills experiencing large settlements may require special designs beyond the scope of this practice. The designer should evaluate each specific site to determine the suitability for use of HDPE manholes and the designer should prepare a written specification for installation, which is beyond the scope of this practice.

5. Materials

5.1 *HDPE Material*—Manhole components, such as the riser, base, and anchor connection ring, shall be made of HDPE plastic compound having a cell classification of 334433C or higher, in accordance with Specification D3350.

NOTE 1—Materials for use in manholes may be subjected to significant tensile and compressive stresses. The material must have a proven capacity for sustaining long-term stresses. There are no existing ASTM standards that establish such a stress rating except for Test Method D2837. Work is currently in progress to develop an alternate method for stress rating materials and when completed, this standard will be altered accordingly.

5.2 *Other Material*—Manhole components, such as tops and lids, may be fabricated from materials other than HDPE as long as agreed to by the user and manufacturer.

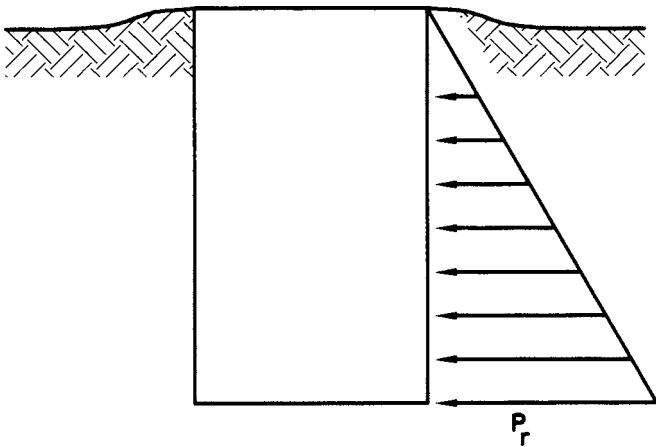

FIG. 2 Radial Pressure Acting on Manhole (Assumed Distribution for Design)

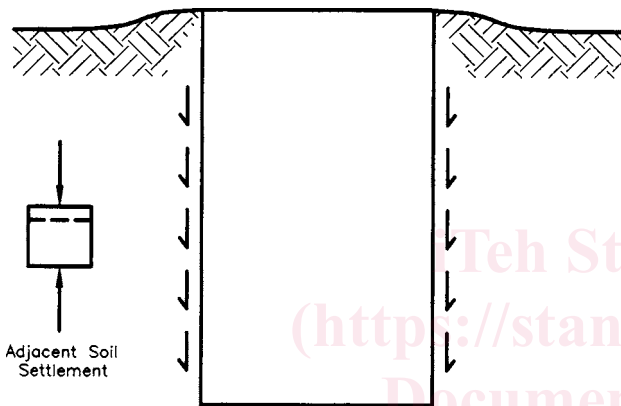

FIG. 3 Downdrag Force Acting on Manhole (Assumed for Design)

Gartung et al. (2) and on the ability of the material placed around the manhole to accept tangential stresses and thus relieve some of the lateral pressure. It may actually understate the load on the manhole, however this appears to be offset by the stress relaxation that occurs in the HDPE manhole as shown by Hossain (3). Stress relaxation permits mobilization of horizontal arching, thus the active earth pressure can be assumed for design purposes.

6.2.1.1 If the active earth pressure is modified to take into account uneven compaction around the perimeter of the pipe as described by Steinfeld and Partner (4), the radially directed design pressure is given by Eq 1.

$$P_R = 1.21 K_A \gamma H \quad (1)$$

where:

P_R = applied radial pressure, psf (kPa),

γ = soil unit weight, lbs/ft³ (kN/m³),

H = weight of fill, ft (m), and

K_A = active earth pressure coefficient as given by Eq 2.

$$K_A = \tan^2 \left(45 - \frac{\phi}{2} \right) \quad (2)$$

where:

ϕ = angle of internal friction of manhole embedment material, °.

6.2.2 Downdrag (Axial Shear Stress)—The settlement of backfill material surrounding a manhole riser develops a shear stress between the manhole and the fill, which acts as “down-drag” along the outside of the manhole. The settling process begins with the first lift of fill placed around the manhole and continues until all the fill is placed and consolidated. As fill is placed around a manhole, the axial force coupled into the manhole by downdrag shear will increase until it equals the frictional force between the soil and manhole. When this limit is reached, slippage of the fill immediately adjacent to the manhole occurs. This limits the axial force to the value of the frictional force.

6.2.2.1 Downdrag loads can be calculated using finite element methods, field measurements, or other procedures. In lieu of these, the following method may be used. The average shear stress is given by Eq 3, for an active earth pressure distribution as shown in Fig. 2.

$$T_A = \mu \left[\frac{P_{R1} + P_{R2}}{2} \right] \quad (3)$$

where:

T_A = average shear (frictional) stress, psf (kPa),

P_{R1} = radial earth pressure at top of manhole, psf (kPa),

P_{R2} = radial earth pressure at bottom of manhole, psf (kPa), and

μ = coefficient of friction between manhole and soil.

6.2.2.2 The coefficient of friction between an HDPE manhole with an essentially smooth outer surface and a granular or granular-cohesive soil can be taken as 0.4. See Swan et al. (5) and Martin et al. (6). In some applications the coefficient of friction may be reduced by coating the exterior of the manhole with bentonite or some other lubricant.

NOTE 3—The use of external stiffeners or open profiles to stiffen the riser greatly increases the downdrag load due to their impeding the settlement of soil beside the manhole. This has the effect of increasing the average shear stress in Eq 3. Where open profiles are used, the coefficient

6. Subsurface Loading on Manhole Riser

6.1 Performance Limits—The manhole riser’s performance limits include ring deflection, ring (hoop) and axial stress (or strain), and ring and axial buckling. Radially directed loads acting on a manhole cause ring deformation and ring bending stresses. The radial load varies along the length of the manhole. See Fig. 2. In addition to radial stresses, considerable axial stress may exist in the manhole wall as a result of “downdrag”. Downdrag occurs as the backfill soil surrounding the manhole consolidates and settles. Axial load is induced through the frictional resistance of the manhole to the backfill settlement. See Fig. 3. The manhole must also be checked for axial compressive stress and axial buckling due to downdrag forces.

6.2 Earth Pressure Acting on Manhole Riser:

6.2.1 Radial Pressure—Radial pressure along the length of the manhole riser may be calculated using finite element methods, field measurements, or other suitable means. See Hossain and Lytton (1).³ In lieu of the preceding, the active earth pressure modified for uneven soil compaction around the perimeter of the riser can be used.

NOTE 2—Use of the active pressure is based on measurements taken by

³ The boldface numbers given in parentheses refer to a list of references at the end of the text.

of friction may equal or exceed 1.0.

6.2.2.3 The downdrag creates an axial-directed load (down-drag load) in the manhole wall that increases with depth. The axial force developed on the manhole can be found by integrating the shear stress (or frictional stress) between the manhole and soil over the height of the fill. This integration is equal to the product of the surface area of the manhole times the average shear stress acting on the surface. The maximum downdrag force can be found using Eq 4. Whether or not to include surface vehicular loads in this term depends on the manhole top design. See 7.3.

$$P_D = T_A \pi \left(\frac{D_o}{12} \right) H \quad (4)$$

where:

P_D = downdrag load, lb (kN),
 D_o = outside diameter of manhole, in. (m),
 T_A = average shear stress, psf (kPa), and
 H = height of fill, ft (m).

NOTE 4—When SI units are used, the 12 in the denominator of Eq 4 may be dropped.

NOTE 5—This equation can be used for HDPE manholes with the recognition that the HDPE manhole is not unyielding. Axial deflection of the HDPE manhole will lessen the downdrag load. The actual load will depend on the relative stiffness between the manhole and the soil and on the effect of stress relaxation properties on the relative stiffness.

6.3 Groundwater Effects:

6.3.1 The presence of groundwater around a manhole exerts an external hydrostatic pressure on the riser as well as a buoyant uplift force on the bottom of the manhole. When soil is submerged beneath the groundwater level, the radial earth pressure acting around the outside diameter of the riser is reduced because the buoyant force of the water reduces the effective weight of the soil. In order to calculate the radial pressure acting on the manhole, the groundwater pressure is added to the radial soil pressure produced by the buoyant weight of the soil. The resulting radial pressure is used when calculating ring performance limits. For axial performance limits that are controlled by downdrag forces, the radial pressure should be calculated as though there was no groundwater, since downdrag forces may occur during construction or otherwise prior to submergence.

6.3.2 *Radial Pressure with Groundwater*—The radial pressure acting in a saturated soil can be calculated using finite element methods, field measurements, or other procedures. In lieu of these, Eq 5 can be used to find the radial pressure in a fully saturated fill surrounding the manhole. (Fully saturated means that the groundwater level is at the ground surface but not above it.)

$$P_R' = \gamma_w H + 1.21 K_A (\gamma_S - \gamma_w) H \quad (5)$$

where:

P_R' = applied radial pressure, psf (kPa),
 K_A = active earth pressure coefficient,
 H = height of fill, ft (m),
 γ_w = unit weight of water, pcf (kN/m³), and
 γ_S = unit weight of saturated soil, pcf (kN/m³).

6.3.3 Where partial saturation of the soil exists, that is where the groundwater level is below the ground surface but

above the manhole invert, the radial pressure can be found by combining the pressure due to the soil above the groundwater level and the pressure given in Eq 5 due to the groundwater and the submerged soil. In this case, H' as given in Eq 6 should be substituted for H in Eq 5. See Appendix X2.

$$H' = H - Z \quad (6)$$

where:

H = weight of manhole, ft (m), and
 Z = distance to water from surface grade, ft (m).

6.3.4 Radial pressure obtained with Eq 5 should not be used to calculate downdrag pressure as the groundwater does not carry shear and thus does not contribute to downdrag. Calculate downdrag forces assuming a dry installation using Eq 1 for radial pressure as described in 6.2.1. Use either the dry weight or the saturated weight of the soil. The saturated weight applies where the groundwater might be drawn down rapidly.

6.3.5 Where manholes are located beneath the groundwater level, consideration should be given to restraining the manhole to prevent flotation. The groundwater exerts a force on the manhole equal to the weight of the water it displaces. Restraint is provided by downward-resisting forces, which include the weight of the manhole and the downdrag load. However, the full downdrag load given by Eq 4 may not develop, as this force may be reduced due to buoyancy. Therefore, it may be necessary to anchor the manhole to a concrete base or ring. When a ring is used, the buoyant weight of the column of soil projecting above the ring can be added to the resisting force and downdrag is neglected. Axial loads in the manhole riser are minimized by keeping the ring close to the manhole base.

7. Design Procedure for HDPE Manholes

7.1 The typical manhole consists of the vertical riser, a floor, a top, and outlets. Each of these components has unique design requirements. The riser must resist groundwater pressure, radial earth pressure, and shear forces due to downdrag induced by settlement of the surrounding soil. It also has to carry the live and dead load weight. The floor has primarily to resist groundwater pressure. The top must transmit live load to the riser. For manholes subjected to vehicular loading, special consideration must be given. See 7.3. Consideration must be given to the attachment of outlets above the invert of the manhole so that they do not induce unduly high bending moments or shear stresses into the riser wall. The load on outlets due to fill settlement increases with the distance the outlets are located above the manhole base.

7.1.1 The manhole riser, floor (bottom), and cone can be designed using finite element analysis, empirical testing, or other means. In lieu of these methods, the methodology given in 7.1-7.3 may be used. This methodology is based on practical experience and field observations and it accounts for arching and viscoelastic effects empirically. Further refinements of this methodology could be made by the following: accounting in a direct way for the earth load reductions due to radial and axial deformations in the manhole structure as a result of the viscoelasticity of the HDPE and the surrounding soil, accounting directly for the benefits of stress relaxation in the HDPE, considering the interaction between axial and ring buckling,

and directly determining the soil's enhancement of the riser's axial buckling resistance.

7.1.1.1 Manhole Riser Design—Design of the manhole riser consists primarily of assuming a trial wall section and checking its performance limits for the radial and downdrag loads. Usually, the maximum loads occur near the deepest buried portion of the manhole. Because loads are lower near the surface, the riser wall thickness can be tapered from bottom to top.

7.1.1.2 Radial Loads—The performance limits under radial loads consist of ring compressive thrust, ring bending, and ring buckling. Ring compression and ring bending create a combined strain in the manhole wall that must be within a limiting strain value.

7.1.1.3 Ring Compressive Thrust—Radial loads acting on the manhole create a compressive hoop thrust. For a vertical riser, the maximum thrust occurs at the deepest section. (Due to the presence of the manhole floor, the maximum thrust actually occurs slightly above the floor.) Eq 7 gives the ring thrust.

$$N_T = \frac{P_R}{144} (R_M) \quad (7)$$

where:

N_T = ring thrust, lb/in. (N/cm),

P_R = applied radial pressure, psf (N/cm²) (1N/cm² = 10 kPa), and

R_M = mean radius of manhole, in. (cm).

For applied radial pressure use Eq 1, if dry, and Eq 5 if groundwater is present.

NOTE 6—When SI units are used, the 144 in the denominator of Eq 7 may be dropped.

7.1.1.4 The ring compressive strain due to the ring thrust is given by Eq 8. In order to calculate the ring compressive strain, a wall section must be assumed.

$$\varepsilon_T = \frac{N_T}{E A_S} \quad (8)$$

where:

ε_T = ring compressive strain, in./in. (cm/cm),

N_T = ring load, lb/in. (N/cm),

E = stress relaxation modulus, psi (N/cm²), and

A_S = manhole cross-sectional area, in.²/in. (cm²/cm). (For solid wall risers, A_S equals the wall thickness.)

7.1.1.5 Ring Bending—The ring strain calculated by Eq 8 will be combined with the bending strain to determine the design adequacy of a proposed wall section.

7.1.1.6 The radial pressures applied to a manhole varies around the circumference due to variability in the fill material and its placement as demonstrated by the 1.21 factor in Eq 1. This eccentricity introduces bending strain in the riser wall. The bending strain can be found either by using an equation that relates the deflection in the riser to the strain (such as Molin's Equation) or by the following method, which considers the bending moment induced by the eccentricity of the thrust load. The eccentricity factor, e , can be calculated from Eq 9. It can be assumed that the ring bending deflections will be low and generally on the order of one or two percent of the manhole diameter.

$$e = C_o (D_M/2) \quad (9)$$

where:

e = eccentricity, in. (cm),

C_o = 0.02 ovality correction factor for 2 % deflection, and

D_M = mean diameter of manhole, in. (cm).

7.1.1.7 The resulting bending moment due to the ring thrust acting over the eccentricity can be found from Eq 10.

$$M_E = e (N_T) (0.5) \quad (10)$$

where:

M_E = bending load, in.-lb/in. (N-cm/cm),

e = eccentricity in. (cm), and

N_T = ring thrust, lb/in.

7.1.1.8 The bending strain, ε_B , for a given section is given in Eq 11.

$$\varepsilon_B = \frac{M_E}{E S_X} \quad (11)$$

where:

ε_B = bending strain, in./in. (cm/cm),

S_X = section modulus, in.³/in. = I/c (cm³/cm),

I = moment of inertia of manhole wall, in.⁴/in. (cm⁴/cm),

c = distance from riser centroid to surface, in. (cm), and

E = stress relaxation modulus of HDPE, psi (N/cm²).

NOTE 7—If the stress relaxation modulus for bending is different than the stress relaxation modulus for compression, the respective values should be used in Eq 8 and Eq 11. (Stress relaxation values may be obtained from the manhole manufacturer or HDPE resin supplier.)

7.1.1.9 Combined Ring Compression and Ring Bending Strain—The total ring strain occurring in the manhole riser wall is given by Eq 12.

$$\varepsilon_C = \varepsilon_T + \varepsilon_B \quad (12)$$

where:

ε_C = combined ring strain, in./in. (cm/cm),

ε_T = compressive thrust strain, in./in. (cm/cm), and

ε_B = bending strain, in./in. (cm/cm).

7.1.1.10 The wall thickness should be designed so that the combined ring strain in Eq 12 is less than the material's permissible strain limit (capacity). Strain capacity of HDPE can vary depending on the particular resin, its molecular weight, and its molecular weight distribution. Because of the variations in HDPE resins and blends, the strain limit should be established for each particular material. The strain limit may be determined by accelerated laboratory testing. Test data for the end-user should be available from the manufacturer.

7.1.1.11 An alternate design approach is to design for stress rather than strain and use an allowable compressive stress value. This method can be used by converting the strain in Eq 12 to a combined stress value.

NOTE 8—The limiting stress approach is usually applied to pressure pipe where the pipe is subjected to long-term hoop stress that must be kept below the threshold for developing slow crack growth within the design life. For several years, it was customary to design non-pressure rated HDPE pipes using an allowable compressive stress approximately equal to the hydrostatic design stress. However, it has recently been shown that the long-term, compressive design stress is higher than the hydrostatic design stress, primarily due to a difference in failure mechanisms.

7.1.1.12 *Ring Buckling*—If the ring compressive thrust stress exceeds a critical value, the manhole can lose its ability to resist flexural deformation and undergo ring buckling. Moore and Selig have used continuum theory to develop design equations for buckling (7). The continuum theory addresses buckling of cylindrical structures surrounded by soil. The presence of groundwater tends to lower the critical buckling value as fluid pressure is not relieved by small deformations that would promote arching in soil. A solution for hydrostatic pressure effects has not yet been published using the continuum theory. At present the most commonly used solution for groundwater effects is Luscher's equation as given in AWWA C-950 (8).

7.1.1.13 *Manhole Section Above Groundwater Level*—The critical ring thrust at which buckling occurs is given by Eq 13. See Moore et al. (9).

$$N_{CR} = 0.7 R_H (EI)^{1/3} (E_S)^{2/3} \quad (13)$$

where:

- N_{CR} = critical ring thrust (no groundwater), lb/in. (N/cm),
- R_H = geometry factor,
- E = stress relaxation modulus, psi (N/cm²),
- I = moment of inertia of manhole wall, in.⁴/in. (cm⁴/cm), and
- E_S = Young's modulus of the soil, psi (N/cm²).

The geometry factor is dependent on the depth of burial and the relative stiffness between the embedment soil and in situ soil. Where the width of the circular zone of fill equals the manhole riser radius, the value of R_H approaches unity as the relative stiffness between the manhole and the soil approaches 0.005. Relative stiffness is defined as:

$$\text{Relative Stiffness} = \frac{2.6 EI}{E_S r^3} \quad (14)$$

where:

- r = radius of manhole riser, in. (cm).

For almost all HDPE manholes installed in a granular or compacted, cohesive-granular embedment, the relative stiffness will be less than 0.005 and R_H equals 1.0. Moore (9) also showed that for deep burial in uniform fills, R_H equals 1.0.

7.1.1.14 For design purposes, the ring thrust as given by Eq 7 should not exceed one-half the critical ring thrust, N_{CR} .

7.1.1.15 *Manhole Section Below Groundwater Level*—The critical thrust for buckling beneath the groundwater level can be determined using Eq 15. See Ref (8).

$$N_{CRW} = 2.825 \sqrt{\frac{RB'E'EI}{D_M}} \quad (15)$$

where:

- N_{CRW} = critical ring thrust (groundwater), lb/in. (N/cm),
- D_M = mean diameter, in. (cm),
- R = 1-33 H'/H , buoyancy reduction factor,
- H' = height of groundwater above invert, ft (m),
- H = height of fill, ft (m),
- E' = modulus of soil reaction, psi (N/cm²),
- E = stress relaxation modulus, psi (N/cm²), and
- I = moment of inertia of manhole wall, in.⁴/in. (cm⁴/cm).

and:

$$B' = \frac{1}{1 + 4e^{(-0.065H)}} \left(B' = \frac{1}{1 + 4e^{(-0.213H)}} \right) \text{ (SI units)} \quad (16)$$

7.1.1.16 For design purposes, the ring thrust as given by Eq 7 should not exceed one-half the critical ring thrust, N_{CRW} .

7.1.1.17 When radial stiffeners are provided in the manhole wall, the average moment of inertia of the wall can be used in the above equations. But, a check should be made to ensure that the spacing between stiffeners does not permit local buckling.

7.1.2 *Axial Load Performance Limits*—In the above section on earth loading, the axial load due to downdrag was given. In addition to the downdrag, other axial loads include the weight of the manhole and its appurtenances and the weight of any live loads, such as equipment or vehicles. These loads create an axial, compressive strain in the manhole wall. The strain is limited by the compressive strain capacity of the material and by the strain limit at axial buckling. Both limits are calculated and the smallest allowable strain controls design.

7.1.2.1 *Axial Strain*—The maximum axial strain induced by the downdrag shear occurs at the riser's lowest point. Assuming uniform downdrag the strain in a solid wall riser is constant around the perimeter of the riser. For profile walls, the axial strain will vary along the length of the profile and possibly around the perimeter depending on the wall thickness at a given section. The wall thickness at the thinnest point is usually referred to as the "net section" and it equals the manhole wall thickness minus the height of any hollow geometric cores. For solid wall risers, the net wall equals the riser wall thickness.

The maximum axial strain occurs at the net section. The maximum axial, compressive strain, ϵ_A , resulting from the downdrag force acting in the net section of the riser wall is given by Eq 17.

$$\epsilon_A = \frac{P_D + P_l + P_w}{E\pi D_M t_n} \quad (17)$$

where:

- ϵ_A = axial compressive strain, in./in. (cm/cm),
- P_D = downdrag force from Eq 4, lb (N),
- P_l = live load, lb (N),
- P_w = dead load including riser weight, lb (N),
- E = stress relaxation modulus, psi (N/cm²),
- D_M = mean diameter of manhole, in. (cm), and
- t_n = net wall thickness, in. (cm).

7.1.2.2 For design, the maximum axial strain must be less than the allowable strain for the manhole material.

7.1.2.3 *Axial Buckling*—As the axial strain is increased in a cylindrical tube, supported by soil, the tube is subject to local buckling rather than column buckling. In the lowest (local) buckling modes, the tube will deflect outward slightly and dimple inward. For a buried manhole, the resistance to buckling in this manner is increased by the surrounding soil, which acts to restrain outward deflection. Buckling equations for a cylindrical tube with no soil support are given in the literature. These equations can be used for manhole design but give a conservative value in cases where the surrounding soil is a stable, well-compacted granular material.