

---

---

**Geotechnical investigation and testing —  
Field testing —**

**Part 2:  
Dynamic probing**

*Reconnaissance et essais géotechniques — Essais en place —  
Partie 2: Essai de pénétration dynamique*  
**(standards.iteh.ai)**

[ISO 22476-2:2005](https://standards.iteh.ai/catalog/standards/sist/0b4345b9-7671-4835-906b-7da41eb3fd90/iso-22476-2-2005)

<https://standards.iteh.ai/catalog/standards/sist/0b4345b9-7671-4835-906b-7da41eb3fd90/iso-22476-2-2005>



**PDF disclaimer**

This PDF file may contain embedded typefaces. In accordance with Adobe's licensing policy, this file may be printed or viewed but shall not be edited unless the typefaces which are embedded are licensed to and installed on the computer performing the editing. In downloading this file, parties accept therein the responsibility of not infringing Adobe's licensing policy. The ISO Central Secretariat accepts no liability in this area.

Adobe is a trademark of Adobe Systems Incorporated.

Details of the software products used to create this PDF file can be found in the General Info relative to the file; the PDF-creation parameters were optimized for printing. Every care has been taken to ensure that the file is suitable for use by ISO member bodies. In the unlikely event that a problem relating to it is found, please inform the Central Secretariat at the address given below.

**iTeh STANDARD PREVIEW**  
**(standards.iteh.ai)**

[ISO 22476-2:2005](#)

<https://standards.iteh.ai/catalog/standards/sist/0b4345b9-7671-4835-906b-7da41eb3fd90/iso-22476-2-2005>

© ISO 2005

All rights reserved. Unless otherwise specified, no part of this publication may be reproduced or utilized in any form or by any means, electronic or mechanical, including photocopying and microfilm, without permission in writing from either ISO at the address below or ISO's member body in the country of the requester.

ISO copyright office  
Case postale 56 • CH-1211 Geneva 20  
Tel. + 41 22 749 01 11  
Fax + 41 22 749 09 47  
E-mail [copyright@iso.org](mailto:copyright@iso.org)  
Web [www.iso.org](http://www.iso.org)

Published in Switzerland

## Foreword

ISO (the International Organization for Standardization) is a worldwide federation of national standards bodies (ISO member bodies). The work of preparing International Standards is normally carried out through ISO technical committees. Each member body interested in a subject for which a technical committee has been established has the right to be represented on that committee. International organizations, governmental and non-governmental, in liaison with ISO, also take part in the work. ISO collaborates closely with the International Electrotechnical Commission (IEC) on all matters of electrotechnical standardization.

International Standards are drafted in accordance with the rules given in the ISO/IEC Directives, Part 2.

The main task of technical committees is to prepare International Standards. Draft International Standards adopted by the technical committees are circulated to the member bodies for voting. Publication as an International Standard requires approval by at least 75 % of the member bodies casting a vote.

Attention is drawn to the possibility that some of the elements of this document may be the subject of patent rights. ISO shall not be held responsible for identifying any or all such patent rights.

ISO 22476-2 was prepared by the European Committee for Standardization (CEN) in collaboration with Technical Committee ISO/TC 182, *Geotechnics*, Subcommittee SC 1, *Geotechnical investigation and testing*, in accordance with the Agreement on technical cooperation between ISO and CEN (Vienna Agreement).

ISO 22476 consists of the following parts, under the general title *Geotechnical investigation and testing — Field testing*:

- *Part 1: Electrical cone and piezocone penetration tests*
- *Part 2: Dynamic probing*
- *Part 3: Standard penetration test*
- *Part 4: Menard pressuremeter test*
- *Part 5: Flexible dilatometer test*
- *Part 6: Self-boring pressuremeter test*
- *Part 7: Borehole jack test*
- *Part 8: Full displacement pressuremeter test*
- *Part 9: Field vane test*
- *Part 10: Weight sounding test*
- *Part 11: Flat dilatometer test*
- *Part 12: Lefranc permeability test*
- *Part 13: Water pressure test in rock*
- *Part 14: Pumping tests*

## Contents

	page
Foreword.....	v
1 Scope .....	1
2 Normative references .....	1
3 Terms and definitions .....	1
4 Equipment .....	3
5 Test procedure .....	6
6 Test results .....	8
7 Reporting .....	8
Annex A (informative) Summary log for dynamic probing.....	11
Annex B (informative) Record of measured values and test results for dynamic probing .....	12
Annex C (informative) Recommended method to measure the actual energy .....	13
Annex D (informative) Geotechnical and equipment influences on the dynamic probing results.....	16
Annex E (informative) Interpretation of test results by using the dynamic point resistance.....	26
Bibliography .....	30

[ISO 22476-2:2005](https://standards.iteh.ai/catalog/standards/sist/0b4345b9-7671-4835-906b-7da41eb3fd90/iso-22476-2-2005)

<https://standards.iteh.ai/catalog/standards/sist/0b4345b9-7671-4835-906b-7da41eb3fd90/iso-22476-2-2005>

## Foreword

This document (EN ISO 22476-2:2005) has been prepared by Technical Committee CEN/TC 341 "Geotechnical investigation and testing", the secretariat of which is held by DIN, in collaboration with Technical Committee ISO/TC 182 "Geotechnics".

This European Standard shall be given the status of a national standard, either by publication of an identical text or by endorsement, at the latest by July 2005, and conflicting national standards shall be withdrawn at the latest by July 2005.

EN ISO 22476 *Geotechnical investigation and testing - Field testing* has the following parts:

— *Part 1: Electrical cone and piezocone penetration tests*

— *Part 2: Dynamic probing*

— *Part 3: Standard penetration test*

— *Part 4: Ménard pressuremeter test*

— *Part 5: Flexible dilatometer test*

— *Part 6: Self-boring pressuremeter test*

— *Part 7: Borehole jack test*

— *Part 8: Full displacement pressuremeter test*

— *Part 9: Field vane test*

— *Part 10: Weight sounding test*

— *Part 11: Flat dilatometer test*

— *Part 12: Mechanical cone penetration test*

— *Part 13: Plate loading test*

According to the CEN/CENELEC Internal Regulations, the national standards organizations of the following countries are bound to implement this European Standard : Austria, Belgium, Cyprus, Czech Republic, Denmark, Estonia, Finland, France, Germany, Greece, Hungary, Iceland, Ireland, Italy, Latvia, Lithuania, Luxembourg, Malta, Netherlands, Norway, Poland, Portugal, Slovakia, Slovenia, Spain, Sweden, Switzerland and United Kingdom.

**iTeh STANDARD PREVIEW**  
**(standards.iteh.ai)**

ISO 22476-2:2005

<https://standards.iteh.ai/catalog/standards/sist/0b4345b9-7671-4835-906b-7da41eb3fd90/iso-22476-2-2005>

## 1 Scope

This document specifies requirements for indirect investigations of soil by dynamic probing as part of geotechnical investigation and testing according to EN 1997-1 and EN 1997-2.

This document covers the determination of the resistance of soils and soft rocks in situ to the dynamic penetration of a cone. A hammer of a given mass and given height of fall is used to drive the cone. The penetration resistance is defined as the number of blows required to drive the cone over a defined distance. A continuous record is provided with respect to depth but no samples are recovered.

Four procedures are included, covering a wide range of specific work per blow:

- dynamic probing light (DPL): test representing the lower end of the mass range of dynamic equipment;
- dynamic probing medium (DPM): test representing the medium mass range of dynamic equipment;
- dynamic probing heavy (DPH): test representing the medium to very heavy mass range of dynamic equipment;
- dynamic probing super heavy (DPSH): test representing the upper end of the mass range of dynamic equipment.

The test results of this document are specially suited for the qualitative determination of a soil profile together with direct investigations (e.g. sampling according to prEN ISO 22475-1) or as a relative comparison of other in situ tests. They may also be used for the determination of the strength and deformation properties of soils, generally of the cohesionless type but also possibly in fine-grained soils, through appropriate correlations. The results can also be used to determine the depth to very dense ground layers e.g. to determine the length of end bearing piles, and to detect very loose, voided, back-filled or infilled ground.

[ISO 22476-2:2005](https://standards.iteh.ai/catalog/standards/sist/0b4345b9-7671-4835-906b-7da41eb3fd90/iso-22476-2-2005)

<https://standards.iteh.ai/catalog/standards/sist/0b4345b9-7671-4835-906b-7da41eb3fd90/iso-22476-2-2005>

## 2 Normative references

The following referenced documents are indispensable for the application of this document. For dated references, only the edition cited applies. For undated references, the latest edition of the referenced document (including any amendments) applies.

EN 10204, *Metallic products — Types of inspection documents*

prEN ISO 22475-1, *Geotechnical investigation and testing — Sampling by drilling and excavation methods and groundwater measurements — Part 1: Technical principles for execution (ISO/DIS 22475-1:2004)*

## 3 Terms and definitions

For the purpose of this document, the following terms and definitions apply.

### 3.1

#### **dynamic penetrometer**

cone and drive rods

### 3.2

#### **dynamic probing equipment**

penetrometer and all equipment necessary to drive the penetrometer

**3.3  
anvil or drive head**

portion of the drive-weight assembly that the hammer strikes and through which the hammer energy passes into the drive rods

**3.4  
cushion; damper**

placed upon the anvil to minimise damage to the equipment

**3.5  
hammer**

portion of the drive-weight assembly which is successively lifted and dropped to provide the energy that accomplishes the penetration of the cone

**3.6  
height of fall**

free fall of the hammer after being released

**3.7  
drive-weight assembly**

device consisting of the hammer, the hammer fall guide, the anvil and the drop system

**3.8  
drive rods**

rods that connect the drive-weight assembly to the cone

iTeh STANDARD PREVIEW  
(standards.iteh.ai)

**3.9  
cone**

pointed probe of standard dimensions used to measure the resistance to penetration (see Figure 1)

**3.10  
actual energy; driving energy**

$E_{\text{meas}}$

energy delivered by the drive-weight assembly into the drive rod immediately below the anvil, as measured

[ISO 22476-2:2005](https://standards.iteh.ai/catalog/standards/sist/0b4345b9-7671-4835-906b-7da41eb3fd90/iso-22476-2-2005)

<https://standards.iteh.ai/catalog/standards/sist/0b4345b9-7671-4835-906b-7da41eb3fd90/iso-22476-2-2005>

**3.11  
theoretical energy**

$E_{\text{theor}}$

energy as calculated for the drive weight assembly,

$$E_{\text{theor}} = m \times g \times h$$

where

$m$  is the mass of the hammer;

$g$  is the acceleration due to gravity;

$h$  is the falling height of the hammer.

**3.12  
energy ratio**

$E_r$

ratio of the actual energy  $E_{\text{meas}}$  and the theoretical energy  $E_{\text{theor}}$  of the hammer expressed in percentage

**3.13  
 $N_{xy}$ -value**

number of blows required to drive the penetrometer over a defined distance  $x$  (expressed in centimetres) by the penetrometer  $y$



### 3.14 specific work per blow

$E_n$   
value calculated by

$$E_n = m \times g \times h/A = E_{\text{theor}}/A$$

where

- $m$  is the mass of the hammer;
- $g$  is the acceleration due to gravity;
- $h$  is the falling height of the hammer;
- $A$  is the nominal base area (calculated using the base diameter  $D$ );
- $E_{\text{theor}}$  is the theoretical energy.

## 4 Equipment

### 4.1 Driving device

Dimensions and masses of the components of the driving device are given in Table 1. The following requirements shall be fulfilled:

- a) hammer shall be conveniently guided to ensure minimal resistance during the fall;
- b) automatic release mechanism shall ensure a constant free fall, with a negligible speed of the hammer when released and no induced parasitic movements in the drive rods;
- c) steel drive head or anvil should be rigidly connected to the top of the drive rods. A loose connection can be chosen;
- d) guide to provide verticality and lateral support for that part of the string of rods protruding above the ground should be part of the driving device.

If a pneumatic system for lifting a hammer is used, it shall be supplied with inspection documents as stipulated by EN 10204 because the driving energy is not always ensured.

### 4.2 Anvil

The anvil shall be made of high strength steel. A damper or cushion may be fitted between the hammer and anvil.

### 4.3 Cone

The cone of steel shall have an apex angle of 90° and an upper cylindrical extension mantle and transition to the extension rods as shown in Figure 1 and with the dimensions and tolerances given in Table 1. The cone may be either retained (fixed) for recovery or disposable (lost). When using a disposable cone the end of the drive rod shall fit tightly into the cone. Alternative specifications for the cones are given in Figure 1.

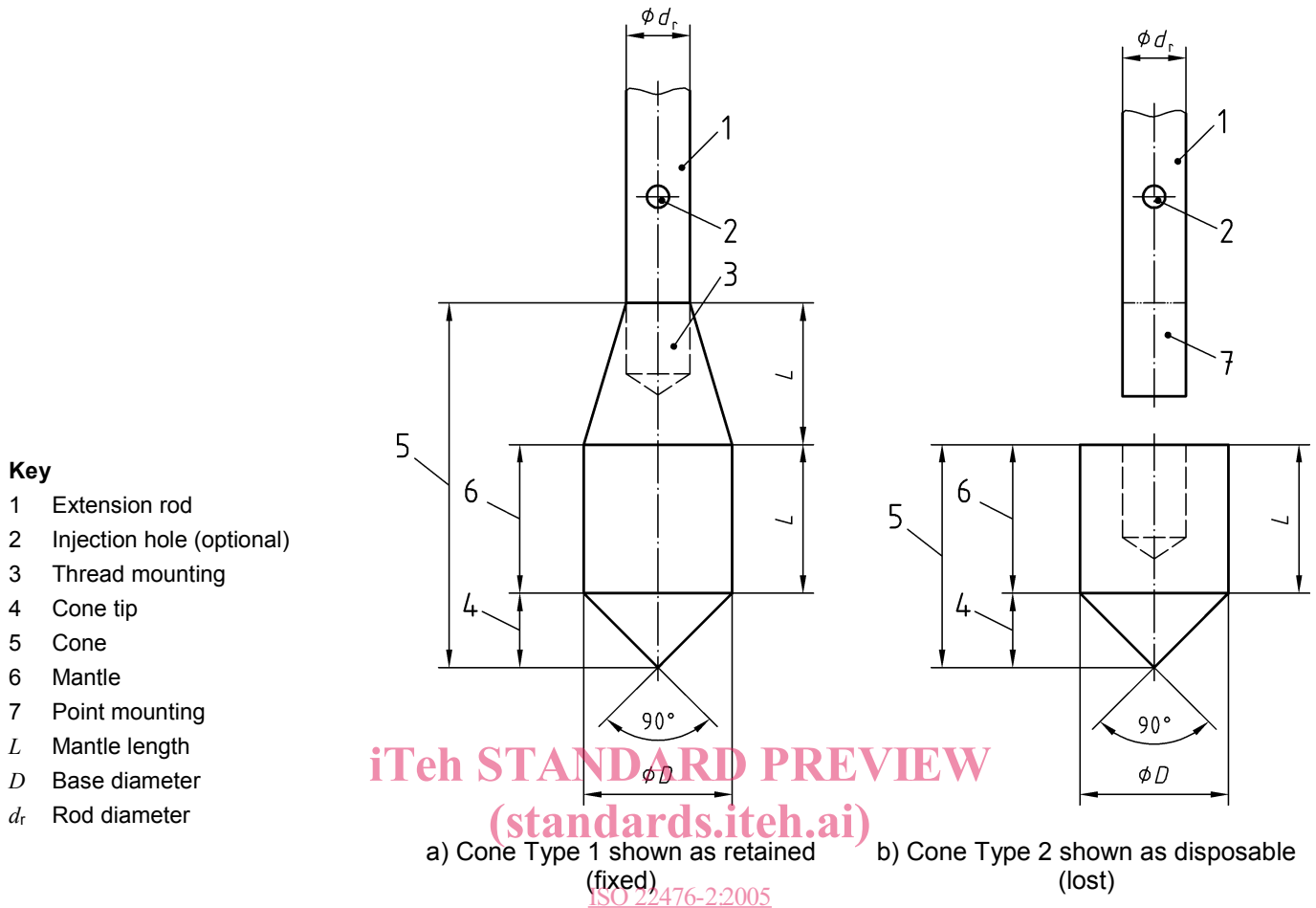

iTeh STANDARD PREVIEW  
 (standards.iteh.ai)

ISO 22476-2:2005  
<https://standards.iteh.ai/catalog/standards/sist/0b4345b9-7671-4835-906b-7da41eb3f190/iso-22476-2-2005>

**Figure 1 – Alternative forms of cones for dynamic probing (for  $L$ ,  $D$  and  $d_r$  see Table 1)**

**4.4 Drive rods**

The rod material shall be of a high-strength steel with the appropriate characteristics for the work to be performed without excessive deformations and wear. The rods shall be flush jointed, shall be straight and may have spanner flats. Deformations shall be capable of being corrected. The deflection at the mid point of an extension rod measured from a straight line through the ends shall not exceed 1 in 1 000, i.e. 1 mm in 1 m. Dimensions and masses of the drive rods are given in Table 1.

Hollow rods should be used.

**4.5 Torque measuring device**

The torque necessary to turn the driving rods is measured by means of a torque wrench or similar measuring device. The apparatus shall be able to measure a torque of at least 200 Nm and be graduated to read at least in 5 Nm increments.

A sensor for recording the torque may be used.

The spanner flat in the drive rods can be used to fix the torque wrench or measuring device.

## 4.6 Optional equipment

### 4.6.1 Blow counter

A device to count the number of blows of the hammer by measuring mechanical or electric impulses can be placed on the system.

### 4.6.2 Penetration length measuring device

The penetration length is measured either by counting on a scale on the rods or by recording sensors. In this latter case, resolution shall be better than 1/100 of the measure length.

### 4.6.3 Injection system

The injection system includes:

- hollow rods;
- solid end of the lowest when using disposable (lost) cone;
- pump with mud connected to a device fixed under the anvil and intended to ensure the filling of the annular space between the ground and the drive rods created by the enlarged cone.

The flow of the pump is such that it will always ensure that the annular space between the ground and the drive rods is filled.

NOTE 1 Mud, for example, can be a mixture of bentonite and water with a mass ratio of dry particles and water of 5 % to 10 %.

NOTE 2 The mud circulation towards the surface is not obligatory. The pressure of injection is that corresponding, after deduction of the head losses, to the hydrostatic pressure due to mud on the level of the cone.

A manual pump may be used.

### 4.6.4 Apparatus for measuring the dimensions of the cone

The measurement of the diameter and length of the cone is made by means of a slide calliper to the 1/10 of mm or by an equivalent system.

### 4.6.5 Device to control rod string deviation from the vertical

A system or guide for supporting the protruding part of the rods should be in place to ensure and check that the drive rods are maintained in a vertical alignment.

Table 1 — Dimensions and masses for the four types of dynamic probing apparatus

Dynamic Probing Apparatus	Symbol	Unit	DPL (light)	DPM (medium)	DPH (heavy)	DPSH (super heavy)	
						DPSH-A	DPSH-B
Driving device							
hammer mass, new	<i>m</i>	kg	10 ± 0,1	30 ± 0,3	50 ± 0,5	63,5 ± 0,5	63,5 ± 0,5
height of fall	<i>h</i>	mm	500 ± 10	500 ± 10	500 ± 10	500 ± 10	750 ± 20
Anvil							
diameter	<i>d</i>	mm	50 < <i>d</i> < <i>D<sub>h</sub></i> <sup>a</sup>	50 < <i>d</i> < <i>D<sub>h</sub></i> <sup>a</sup>	50 < <i>d</i> < 0,5 <i>D<sub>h</sub></i> <sup>a</sup>	50 < <i>d</i> < 0,5 <i>D<sub>h</sub></i>	50 < <i>d</i> < 0,5 <i>D<sub>h</sub></i> <sup>a</sup>
mass (max.) (guide rod included)	<i>m</i>	kg	6	18	18	18	30
90° Cone							
nominal base area	<i>A</i>	cm <sup>2</sup>	10	15	15	16	20
base diameter, new	<i>D</i>	mm	35,7 ± 0,3	43,7 ± 0,3	43,7 ± 0,3	45,0 ± 0,3	50,5 ± 0,5
base diameter, worn (min.)		mm	34	42	42	43	49
mantle length (mm)	<i>L</i>	mm	35,7 ± 1	43,7 ± 1	43,7 ± 1	90,0 ± 2 <sup>b</sup>	51 ± 2
length of cone tip		mm	17,9 ± 0,1	21,9 ± 0,1	21,9 ± 0,1	22,5 ± 0,1	25,3 ± 0,4
tip max. permissible wear		mm	3	4	4	5	5
Drive rods <sup>c</sup>							
mass (max)	<i>m</i>	kg/m	3	6	6	6	8
diameter OD (max)	<i>d<sub>r</sub></i>	mm	22	32	32	32	35
rod deviation <sup>d</sup> :							
lowermost 5 m		%	0,1	0,1	0,1	0,1	0,1
remainder		%	0,2	0,2	0,2	0,2	0,2
Specific work per blow	$\frac{mgh}{A}$ <i>E<sub>n</sub></i>	kJ/m <sup>2</sup>	50	100	167	194	238

<sup>a</sup> *D<sub>h</sub>* diameter of the hammer, in case of rectangular shape, the smaller dimension is assumed to be equivalent to the diameter.

<sup>b</sup> disposable cone only

<sup>c</sup> maximum rod length shall not exceed 2 m

<sup>d</sup> rod deviation from the vertical

NOTE Tolerances given are manufacturing tolerances.

## 5 Test procedure

### 5.1 Equipment checks and calibrations

Prior to each test, a check of dimensions shall be made to ensure that they are within the values given in Table 1. The straightness of the rods shall be checked once on each new site and at least every 20 penetration tests at that site. After each test, a visual check of the straightness of the rods shall be made.