

---

---

**Textile glass — Rovings — Manufacture  
of test specimens and determination of  
tensile strength of impregnated rovings**

*Verre textile — Stratifils — Fabrication d'éprouvettes et essai de traction  
sur stratifil imprégné*

iTeh Standards  
(<https://standards.iteh.ai>)  
Document Preview

[ISO 9163:2005](https://standards.iteh.ai/catalog/standards/iso/d42aedd3-b432-4824-beb8-08a7ccc8c6f4/iso-9163-2005)

<https://standards.iteh.ai/catalog/standards/iso/d42aedd3-b432-4824-beb8-08a7ccc8c6f4/iso-9163-2005>



**PDF disclaimer**

This PDF file may contain embedded typefaces. In accordance with Adobe's licensing policy, this file may be printed or viewed but shall not be edited unless the typefaces which are embedded are licensed to and installed on the computer performing the editing. In downloading this file, parties accept therein the responsibility of not infringing Adobe's licensing policy. The ISO Central Secretariat accepts no liability in this area.

Adobe is a trademark of Adobe Systems Incorporated.

Details of the software products used to create this PDF file can be found in the General Info relative to the file; the PDF-creation parameters were optimized for printing. Every care has been taken to ensure that the file is suitable for use by ISO member bodies. In the unlikely event that a problem relating to it is found, please inform the Central Secretariat at the address given below.

**iTeh Standards**  
**(<https://standards.iteh.ai>)**  
**Document Preview**

[ISO 9163:2005](https://standards.iteh.ai/catalog/standards/iso/d42aedd3-b432-4824-beb8-08a7ccc8c6f4/iso-9163-2005)

<https://standards.iteh.ai/catalog/standards/iso/d42aedd3-b432-4824-beb8-08a7ccc8c6f4/iso-9163-2005>

© ISO 2005

All rights reserved. Unless otherwise specified, no part of this publication may be reproduced or utilized in any form or by any means, electronic or mechanical, including photocopying and microfilm, without permission in writing from either ISO at the address below or ISO's member body in the country of the requester.

ISO copyright office  
Case postale 56 • CH-1211 Geneva 20  
Tel. + 41 22 749 01 11  
Fax + 41 22 749 09 47  
E-mail [copyright@iso.org](mailto:copyright@iso.org)  
Web [www.iso.org](http://www.iso.org)

Published in Switzerland

## Contents

	Page
<b>1 Scope</b> .....	<b>1</b>
<b>2 Normative references</b> .....	<b>1</b>
<b>3 Terms and definitions</b> .....	<b>1</b>
<b>4 Principle</b> .....	<b>2</b>
<b>5 Sampling and conditioning</b> .....	<b>2</b>
<b>6 Production of test specimens — Reference method</b> .....	<b>3</b>
<b>7 Production of test specimens — Short method</b> .....	<b>13</b>
<b>8 Tensile testing</b> .....	<b>15</b>
<b>9 Expression of results</b> .....	<b>18</b>
<b>10 Test report</b> .....	<b>19</b>
<b>Annex A (informative) Precision statement</b> .....	<b>20</b>
<b>Bibliography</b> .....	<b>21</b>

iTeh Standards  
(<https://standards.itih.ai>)  
Document Preview

[ISO 9163:2005](https://standards.itih.ai/catalog/standards/iso/d42aedd3-b432-4824-beb8-08a7ccc8c6f4/iso-9163-2005)

<https://standards.itih.ai/catalog/standards/iso/d42aedd3-b432-4824-beb8-08a7ccc8c6f4/iso-9163-2005>

## Foreword

ISO (the International Organization for Standardization) is a worldwide federation of national standards bodies (ISO member bodies). The work of preparing International Standards is normally carried out through ISO technical committees. Each member body interested in a subject for which a technical committee has been established has the right to be represented on that committee. International organizations, governmental and non-governmental, in liaison with ISO, also take part in the work. ISO collaborates closely with the International Electrotechnical Commission (IEC) on all matters of electrotechnical standardization.

International Standards are drafted in accordance with the rules given in the ISO/IEC Directives, Part 2.

The main task of technical committees is to prepare International Standards. Draft International Standards adopted by the technical committees are circulated to the member bodies for voting. Publication as an International Standard requires approval by at least 75 % of the member bodies casting a vote.

Attention is drawn to the possibility that some of the elements of this document may be the subject of patent rights. ISO shall not be held responsible for identifying any or all such patent rights.

ISO 9163 was prepared by Technical Committee ISO/TC 61, *Plastics*, Subcommittee SC 13, *Composites and reinforcement fibres*.

This second edition cancels and replaces the first edition (ISO 9163:1996), which has been technically revised, as follows:

- The reference method remains essentially the same, with a few corrections, as in ISO 9163:1996.
- The so-called “fast method” described in ISO 9163:1996 has been deleted because it was no longer used. It has been replaced by a method which needs far less time and gives results consistent with the reference method.

[ISO 9163:2005](https://standards.iteh.ai/catalog/standards/iso/d42aedd3-b432-4824-beb8-08a7ccc8c6f4/iso-9163-2005)

<https://standards.iteh.ai/catalog/standards/iso/d42aedd3-b432-4824-beb8-08a7ccc8c6f4/iso-9163-2005>

# Textile glass — Rovings — Manufacture of test specimens and determination of tensile strength of impregnated rovings

## 1 Scope

This International Standard specifies two methods for the determination of the tensile stress at break of an impregnated roving:

- a reference method using test specimens produced with moulded epoxy tabs;
- a short method using test specimens with no tabs or simple cardboard or composite tabs.

The methods are applicable to both assembled (multistrand) and direct (multifilament) rovings; nevertheless the reference method may be used for various linear densities, but the short method is described for 1 200 tex rovings only, which is the linear density that allows the fibres in the roving to spread out most easily during impregnation.

## 2 Normative references

The following referenced documents are indispensable for the application of this document. For dated references, only the edition cited applies. For undated references, the latest edition of the referenced document (including any amendments) applies.

ISO 291, *Plastics — Standard atmospheres for conditioning and testing*

ISO 472, *Plastics — Vocabulary*

ISO 1172, *Textile-glass-reinforced plastics — Prepregs, moulding compounds and laminates — Determination of the textile-glass and mineral-filler content — Calcination methods*

ISO 1887, *Textile glass — Determination of combustible-matter content*

ISO 1889, *Reinforcement yarns — Determination of linear density*

ISO 2078, *Textile glass — Yarns — Designation*

ISO 2859-1, *Sampling procedures for inspection by attributes — Part 1: Sampling schemes indexed by acceptance quality limit (AQL) for lot-by-lot inspection*

ISO 3951-1, *Sampling procedures for inspection by variables — Part 1: Specification for single sampling plans indexed by acceptance quality limit (AQL) for lot-by-lot inspection for a single quality characteristic and a single AQL*

ISO 7822, *Textile glass reinforced plastics — Determination of void content — Loss on ignition, mechanical disintegration and statistical counting methods*

## 3 Terms and definitions

For the purposes of this document, the terms and definitions given in ISO 472 and the following apply.

- 3.1  
breaking force**  
force or load required to rupture a test specimen in a tensile test, usually expressed in newtons
- 3.2  
gauge length**  
nominal length between the spines of contact of an extensometer (expressed in millimetres), by reference to which the length increase due to a tensile force is determined
- 3.3  
relative elongation**  
ratio of the increase in length (expressed in millimetres) between the spines of contact of an extensometer, resulting from application of a tensile force, to the gauge length of the extensometer (also expressed in millimetres)
- 3.4  
breaking stress**  
ratio (expressed in megapascals) of the breaking force (expressed in newtons) to the cross-sectional area of a roving (expressed in square millimetres)
- 3.5  
loading stress**  
ratio (expressed in megapascals) of the tensile force applied to a roving during a tensile test (expressed in newtons) to the cross-sectional area of the roving (expressed in square millimetres)

NOTE The force experienced by the resin can be neglected.

**3.6  
cross-sectional area**

$S$   
area of the cross-section of a roving given, in square millimetres, by the formula:

$$\frac{\rho_l \times 10^{-3}}{\rho_g} \quad \text{ISO 9163:2005} \quad (1)$$

where

- $\rho_l$  is the exact linear density of the unsized roving, in tex;
- $\rho_g$  is the density of the glass constituting the roving, in grams per cubic centimetre.

**3.7  
proportional limit**  
greatest stress (expressed in megapascals) for which the relative elongation is proportional to the applied force

## 4 Principle

A specimen of impregnated roving is subjected to tensile loading to rupture using a suitable mechanical apparatus, and the breaking stress of the specimen determined.

## 5 Sampling and conditioning

Carry out sampling in accordance with ISO 2859-1, using the “inspection by attributes” method, or in accordance with ISO 3951-1, using the “inspection by variables” method in order to minimize the number of elementary units (packages) to be selected.

Condition the packages selected for at least 12 h in one of the standard atmospheres given in ISO 291.

## 6 Production of test specimens — Reference method

### 6.1 Apparatus

Ordinary laboratory apparatus, plus the following:

**6.1.1 Impregnation apparatus** (see Figure 1), including the following elements:

**6.1.1.1 Reel**, equipped with a tension-regulating system capable of maintaining the roving under a tension between 0,2 N and 20 N by positioning the tensioning bars (see Figure 2) to obtain a correct level of impregnation. The tension can be adjusted by measuring it with a tension-measuring instrument between the reel and the entrance guide.

Dimensions in metres

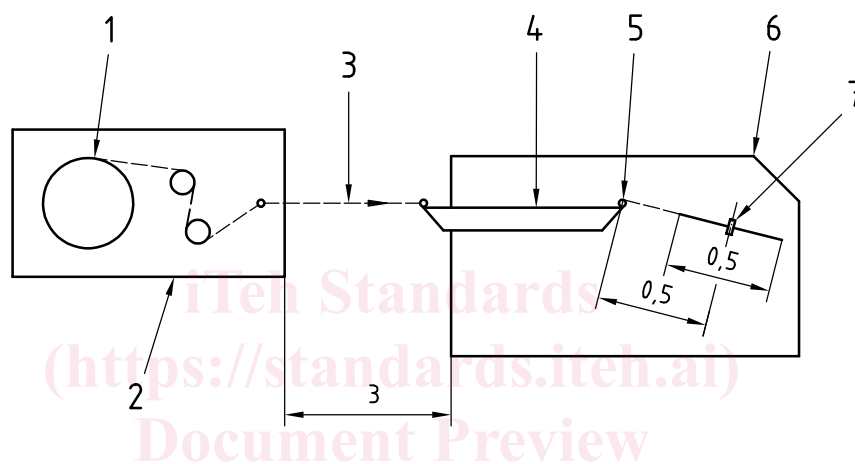

#### Key

- 1 reel
- 2 tension-regulating system
- 3 roving
- 4 impregnation vat
- 5 die
- 6 winding system
- 7 former

**Figure 1 — General layout of impregnation apparatus**

**6.1.1.2 Impregnation vat**, equipped with yarn guides (see Figure 2).

It shall be capable of maintaining a temperature of up to 130 °C with a precision of  $\pm 5$  °C (the actual temperature set will depend on the resin system).

The use of a double-walled vat, with heating fluid circulating between the walls, is recommended. If a vat of this kind is not available, a hotplate may be used.

**6.1.1.3 Stainless-steel die**, designed to give the impregnated roving a defined circular cross-section.

The die shall be mounted on a spindle, permitting it to align itself automatically with the roving during reeling (see Figure 2).

Dimensions in millimetres

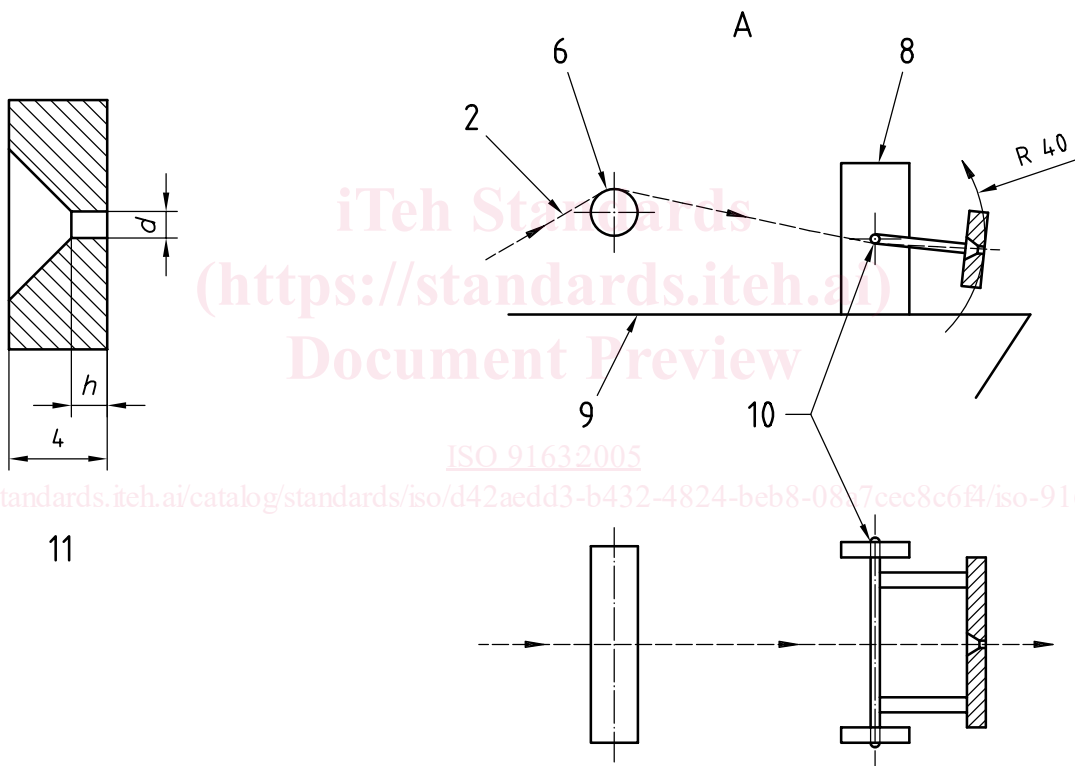
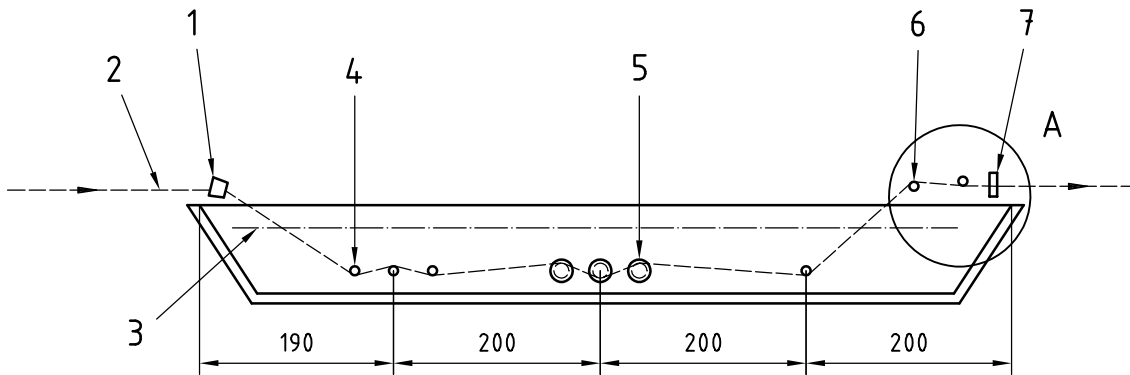

**Key**

- 1 entrance guide (eye type)
- 2 roving
- 3 resin level
- 4 tensioning bars (smooth)
- 5 tensioning bars (grooved)
- 6 exit tensioning bar
- 7 die
- 8 die support
- 9 impregnation vat
- 10 rotating spindle of die,  $\varnothing$  3 mm

NOTE Any equipment which is equivalent to the one illustrated above may be used, provided satisfactory impregnation is obtained. Nevertheless, it is recommended that a die diameter given in Table 1 be used, in order to obtain a reproducible impregnation ratio.

**Figure 2 — Vat and die**



The diameter of the die will depend on the linear density of the roving. It is given by the equation:

$$d = \sqrt{\frac{4\rho_l[(1/G) - (1 + \rho_m)/\rho_g]}{1\,000 \rho_m \pi}} \quad (2)$$

where

$\rho_m$  is the density of the matrix;

$\rho_g$  is the density of the glass in the roving;

$\rho_l$  is the linear density of the roving, in tex;

$G$  is the proportion of glass, by mass, in the composite, expressed as a figure between 0 and 1.

The glass content by mass, determined as specified in ISO 1172, shall be approximately constant at  $(75 \pm 4)$  %.

Table 1 indicates some typical parameters for dies for different tex counts.

**Table 1 — Typical parameters for dies for different tex counts**

$\rho_l$ (tex)	800	1 200	1 600	2 400	4 800
$d^a$ (mm)	0,8	1,1	1,15	1,4	2
$h^a$ (mm)	1	1,3	1,5	2	3
<sup>a</sup> $h$ et $d$ are as indicated in Figure 2.					

**6.1.1.4 Winding device (mechanical or manual) with former**, for collecting the impregnated roving, ensuring that

- the roving is kept under tension;
- the impregnated strands are kept separate from each other.

The collecting speed shall be as constant as possible.

## 6.2 Preparation of test specimens

### 6.2.1 Type and dimensions

Each test specimen shall consist of an impregnated roving with moulded end tabs. Its dimensions shall be as given in Figure 3.

A method for the fabrication of tabs is given in 6.3.

### 6.2.2 Number

For each of the packages selected (see Clause 5), at least 20 test specimens shall be prepared to obtain at least 10 valid readings (five for the determination of the breaking stress and five for the tensile modulus). Testing of more specimens might be necessary for statistical purposes.

Dimensions in millimetres

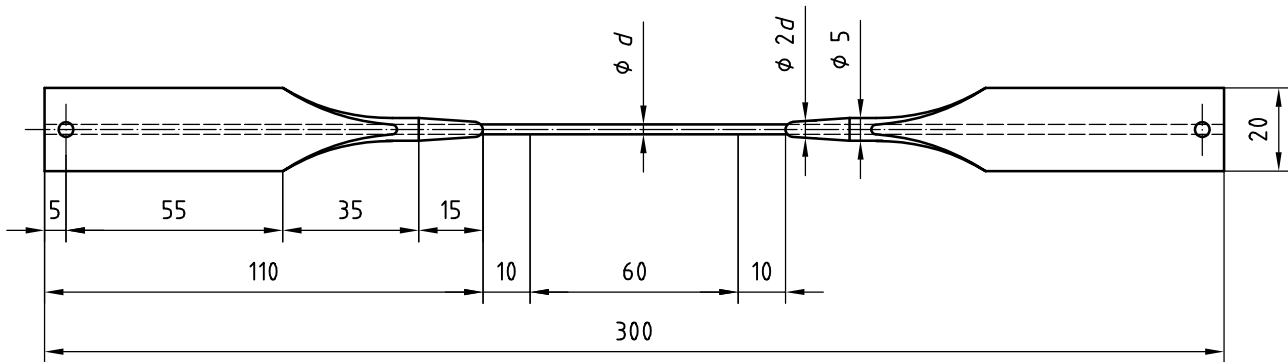

Figure 3 — Test specimen

### 6.2.3 Impregnation procedure

Set up the impregnating apparatus (6.1.1) as shown in Figure 1. Details of the apparatus may vary depending on the type of roving package (reel or ball) and the way in which it is unwound (unravelling or unrolled). Verify that:

- The tension-regulating system and the yarn guide in front of the vat do not cause any damage to the roving.
- The impregnating system and the conditions of passage through the vat are such that they provide an impregnated roving of good quality. The quality of the impregnated roving may be verified by measuring the void content of the material in accordance with ISO 7822. For the purposes of this International Standard, the void content shall be lower than 2 %. If the void content is higher, adjust the tension and/or the diameter of the die to obtain the correct level.

Carry out the following operations:

Place a package on the reel of the tension-regulating system and unwind and discard at least the first three layers of roving.

Install the die appropriate to the linear density of the roving to be impregnated (see Figure 2).

Prepare an impregnating system (polyester or epoxy resin) with the following characteristics:

- viscosity at impregnation temperature lower than  $0,4 \text{ Pa}\cdot\text{s}^1$ ;
- pot life of the system longer than twice the time required for the winding operation;
- minimum elongation at break: 5 %.

Pour the impregnation resin into the vat (see Figure 2) and maintain a continuous check on its temperature. Start the impregnation of the roving when the resin has reached the vat temperature.

Adjust the unwinding tension to about  $3 \text{ mN/tex}$ .

Rotate the former (see Figure 4) at about 2 rpm and as regularly as possible.

Wind on to the former a number of turns equal to at least two times the number required for the test specimens to be produced; cut the roving and attach the free end to the former.

1)  $1 \text{ Pa}\cdot\text{s} = 10 \text{ poises}$