



Designation: F 924 – 90 (Reapproved 2004)

Standard Test Method for Resistance to Puncture of Cushioned Resilient Floor Coverings¹

This standard is issued under the fixed designation F 924; the number immediately following the designation indicates the year of original adoption or, in the case of revision, the year of last revision. A number in parentheses indicates the year of last reapproval. A superscript epsilon (ϵ) indicates an editorial change since the last revision or reapproval.

1. Scope

1.1 This test method covers the laboratory procedure for determining the resistance of cushioned resilient floor coverings to punctures from dropped pointed objects such as dinner forks.

1.2 This test method employs a 35-g cylindrical dart with a flat, small-diameter tip that is dropped onto a specimen of flooring. The dart represents the weight of a typical fork and the tip produces a similar puncture to those which result from dropped forks.

1.3 Flooring with thick wear layers may not puncture under even the most severe drop. Although data can be obtained by increasing the drop height or the weight of the dart, values of this magnitude have no practical application.

1.4 *This standard does not purport to address all of the safety concerns, if any, associated with its use. It is the responsibility of whoever uses this standard to consult and establish appropriate safety and health practices and determine the applicability and regulatory limitations prior to use.* For specific precaution statement see 8.2.

2. Referenced Documents

- 2.1 *ASTM Standards:*²
- E 171 Specification for Standard Atmospheres for Conditioning and Testing Materials
 - F 141 Terminology Relating to Resilient Floor Coverings
 - F 410 Test Method for Wear Layer Thickness of Resilient Floor Coverings by Optical Measurement

3. Terminology

3.1 Definitions:

3.1.1 For definitions of other terms used in this test method, refer to Terminology F 141.

3.2 Definitions of Terms Specific to This Standard:

3.2.1 *puncture*—a break in the wear layer of the specimen. An indentation at the point of impact shall be considered a puncture only if the wear layer is broken completely through at some point.

3.2.2 *wicking*—the presence of ink below the wear layer of the specimen in areas adjacent to a puncture. This can be seen next to the actual cut, and appears either as spots on the pattern layer or as a general discoloration.

4. Significance and Use

4.1 Much of the cushioned resilient flooring in use today is in household kitchens. Kitchen flooring is frequently subjected to the hazard of dropped tableware and cutting knives, that can puncture the wear layer of cushioned resilient flooring. Food and soil that become embedded in these punctures often can not be removed by ordinary maintenance, resulting in unsightly marks. Moisture, grease, or oils that penetrate to the cushion layer can be wicked into the foam and cause permanent discoloration. Ultimately, the service life of the material is shortened.

5. Apparatus

5.1 *Dart Drop Assembly* (Fig. 1), consisting of a ½ in. plywood platform tilted 20° from horizontal, and a vertical slotted tube at least 40 in. (1016 mm) long with an inside diameter of 1.05 ± 0.05 in. (26.7 ± 2 mm). The mouth of the tube shall be approximately 2 in. (50.8 mm) above the center of the platform. The tube shall be marked in 1 in. or less graduations showing the height above the surface of a mounted specimen positioned on the platform. At the top of the tube shall be a flat cap with a ¼ in. diameter opening in the center. This hole should have smooth, rounded sides.

5.2 *Dart* (Fig. 2), consisting of a 0.970 ± 0.003 (246 ± 0.76 mm) outside diameter hollow cylindrical aluminum body with a 0.078 ± 0.0005 in. (2.0 ± 0.013 mm) diameter tip at one end and a steel wire loop at the other end, weighing a total of 35 ± 0.10 g. A length of size “A” silk thread at least 60 in. long shall be attached to the wire loop.

¹ This test method is under the jurisdiction of ASTM Committee F06 on Resilient Floor Coverings and is the direct responsibility of Subcommittee F06.30 on Test Methods-Performance.

Current edition approved Sept. 1, 2004. Published September 2004. Originally approved in 1985. Last previous edition approved in 1999 as F 924 – 90(99).

² For referenced ASTM standards, visit the ASTM website, www.astm.org, or contact ASTM Customer Service at service@astm.org. For *Annual Book of ASTM Standards* volume information, refer to the standard's Document Summary page on the ASTM website.

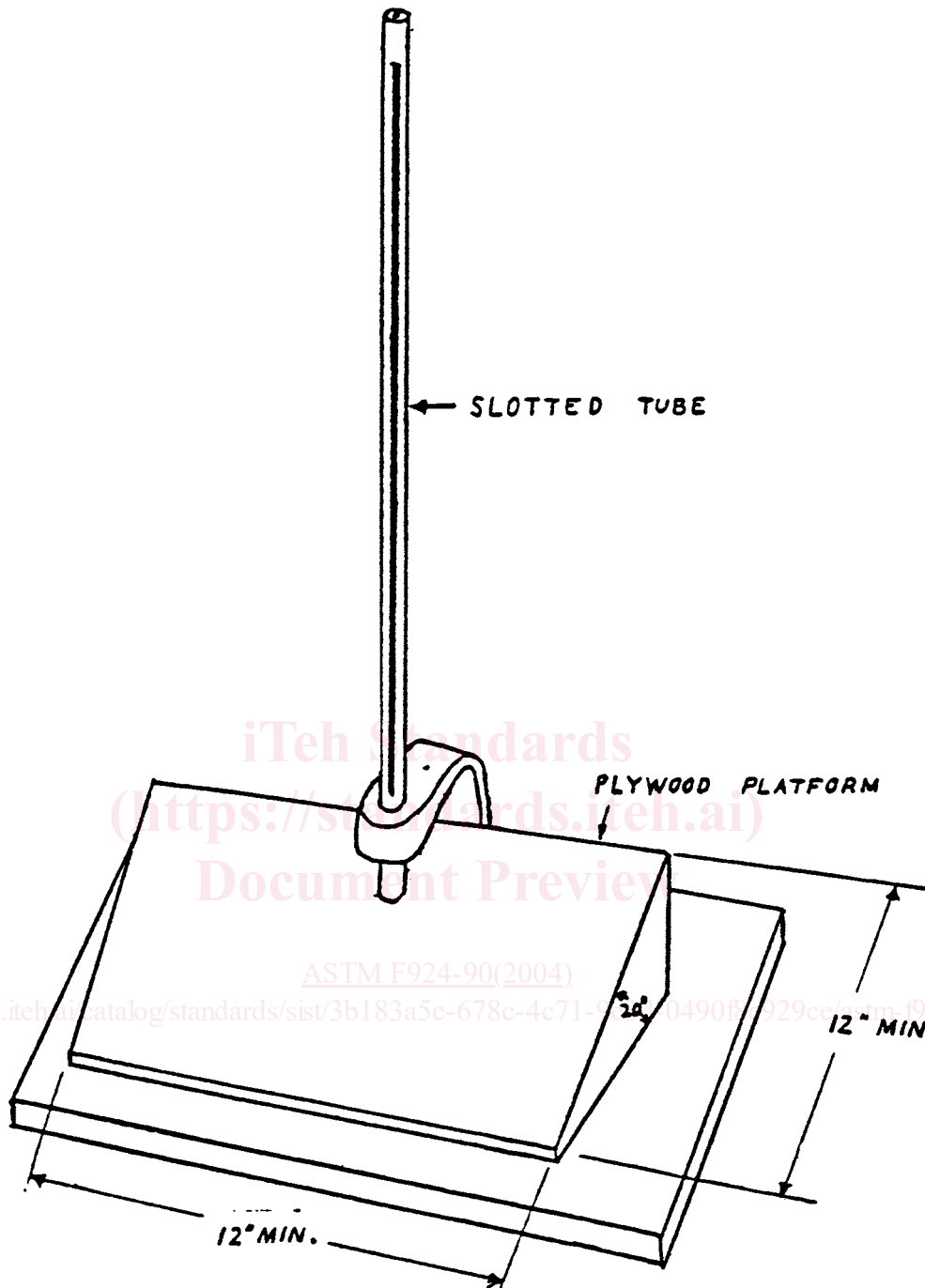

FIG. 1 Dart Drop Assembly

5.3 Microscope or magnifier, 3X or greater.

5.4 Alcohol-based ink.

6. Test Specimens

6.1 The test specimen shall measure approximately 6 by 6 in. (152 by 152 mm).

6.2 The required number of specimens of each sample shall be 6.

7. Conditioning

7.1 Condition the specimens at $73.4 \pm 3.6^\circ\text{F}$. ($23 \pm 2^\circ\text{C}$) and $50 \pm 5\%$ relative humidity in accordance with Specification E 171 for not less than 16 h prior to test.

7.2 Conduct tests in an atmosphere of $73.4 \pm 3.6^\circ\text{F}$ ($23 \pm 2^\circ\text{C}$) and $50 \pm 5\%$ relative humidity.