



Standard Test Method for Thermal Endurance of Flexible Electrical Insulating Varnishes¹

This standard is issued under the fixed designation D 1932; the number immediately following the designation indicates the year of original adoption or, in the case of revision, the year of last revision. A number in parentheses indicates the year of last reapproval. A superscript epsilon (ϵ) indicates an editorial change since the last revision or reapproval.

This standard has been approved for use by agencies of the Department of Defense.

1. Scope

1.1 This test method covers the determination of the relative thermal endurance of flexible electrical insulating varnishes by determining the aging time necessary at elevated temperatures to decrease the dielectric breakdown of the varnish to an arbitrarily selected value when applied to a standard glass fiber fabric.

1.2 This test method does not apply to varnishes that lose a high percentage of their dielectric breakdown voltage when flexed before aging as prescribed in the screening test (Section 9). Examples of such varnishes are those used for high speed armatures and laminated structures. Also, this test method is not applicable to varnishes which distort sufficiently during thermal aging so that they cannot be tested using the curved electrode assembly.

1.3 Thermal endurance is expressed in terms of a temperature index.

1.4 *This standard does not purport to address all of the safety concerns, if any, associated with its use. It is the responsibility of the user of this standard to establish appropriate safety and health practices and determine the applicability of regulatory limitations prior to use.* For specific hazard statements, see Section 7.

1.5 The values stated in SI units are the standard.

NOTE 1—There is no equivalent IEC or ISO standard.

2. Referenced Documents

2.1 ASTM Standards:

D 149 Test Method for Dielectric Breakdown Voltage and Dielectric Strength of Solid Electrical Insulating Materials at Commercial Power Frequencies²

D 374 Test Methods for Thickness of Solid Electrical Insulation²

¹ This test method is under the jurisdiction of ASTM Committee D09 on Electrical and Electronic Insulating Materials and is the direct responsibility of Subcommittee D09.01 on Electrical Insulating Varnishes, Powders, and Encapsulating Compounds.

Current edition approved Sept. 10, 2001. Published November 2001. Originally published as D 1932 – 67. Last previous edition D 1932 – 97.

² *Annual Book of ASTM Standards*, Vol 10.01.

D 580 Specification for Greige Woven Glass Tapes and Webbing³

D 1346 Methods of Testing Electrical Insulating Varnishes for 180°C and Above⁴

D 1711 Terminology Relating to Electrical Insulation²

D 2518 Specification for Woven Glass Fabrics for Electrical Insulation⁵

D 5423 Specification for Forced-Convection Laboratory Ovens for Evaluation of Electrical Insulation⁵

D 6054 Practice for Conditioning Electrical Insulating Materials for Testing⁵

2.2 IEEE Publications:⁶

IEEE No. 101A Guide for the Statistical Analysis of Thermal Life Test Data (including Appendix A)

2.3 IEC Publications:

IEC 60216 Guide for the Determination of Thermal Endurance Properties of Electrical Insulating Materials (Part 1)⁷

3. Terminology

3.1 Definitions:

3.1.1 *temperature index (TI), n*—a number which permits comparison of the temperature/time characteristics of an electrical insulating material, or a simple combination of materials, based on the temperature in degrees Celsius which is obtained by extrapolating the Arrhenius plot of life versus temperature to a specified time, usually 20 000 h.

3.1.2 *thermal endurance graph, n*—an Arrhenius plot.

3.1.3 *thermal life, n*—the time necessary for a specific property of a material, or a simple combination of materials, to degrade to a defined end point when aged at a specified temperature.

3.1.4 *thermal life curve, n*—a graphical representation of thermal life at a specified aging temperature in which the value of a property of a material, or a simple combination of materials, is measured at room temperature and the values

³ *Annual Book of ASTM Standards*, Vol 07.01.

⁴ Discontinued; see 1986 *Annual Book of ASTM Standards*, Vol 10.01.

⁵ *Annual Book of ASTM Standards*, Vol 10.02.

⁶ Available from the Institute of Electrical and Electronics Engineers, 1828 L St., NW, Suite 1202, Washington, DC 20036–5104.

⁷ Available from American National Standards Institute, 25 West 43rd St., 4th Floor, New York, NY 10036.

plotted as a function of time.

3.1.5 Refer to Terminology D 1711 for definitions of other terms.

4. Summary of Test Method

4.1 Specimens are prepared using glass cloth coated with the selected varnish to a specified build.

4.2 Specimens are aged in air at a minimum of three temperatures above the expected use temperature of the material. Dielectric breakdown voltage tests in air at room temperature are periodically made to determine the time of aging at each test temperature required to reduce the breakdown voltage to a value of 12 kV/mm (300 V/mil) of original thickness. These values are used to construct a thermal endurance graph by which temperature indices may be estimated.

4.3 This test method is not applicable to materials having an initial dielectric breakdown voltage of less than 12 kV/mm (300 V/mil) of original thickness unless lower endpoint values are agreed upon or indicated in the applicable material specifications.

5. Significance and Use

5.1 A major factor affecting the life of insulating materials is thermal degradation. Other factors, such as moisture and vibration, may cause failures after the material has been weakened by thermal degradation.

5.2 An electrical insulating varnish is effective in protecting electrical equipment only as long as it retains its physical and electrical integrity.

5.3 The thermal degradation of the varnish results in weight loss, porosity, crazing, and generally a reduction in flexibility. Degradation of the varnish can be detected by a decrease in dielectric strength, which is therefore used as the failure criterion for this test method.

5.4 Electrical insulating varnishes undergo flexing in service due to vibration and thermal expansion. For this reason, this functional test includes flexing and elongation of the

insulation. The electrodes used in this test method are designed to elongate the outer surface of the specimen 2 % with respect to the neutral axis of the base fiber while being tested for dielectric breakdown.

6. Apparatus

6.1 *Electrode Test Fixture*—The fixture shall be in accordance with the dimensions shown in Fig. 1 and Fig. 2. Electrodes shall be of polished brass, with the upper electrode having a mass of 1.8 ± 0.05 kg (4.0 ± 0.1 lb).

6.2 *Dielectric Breakdown Test Set*—The set shall meet the requirements of Test Method D 149.

6.3 *Ovens*—A forced draft constant-temperature oven conforming to Specification D 5423, Type II.

6.4 *Micrometer*—Dead-weight type specified in Test Methods D 374, having a presser foot 6.35 ± 0.03 mm (0.25 ± 0.001 in.) in diameter and an anvil of at least 50 mm (2 in.) diameter and shall exert a pressure of 0.17 ± 0.01 MPa (25 ± 2 psi) on the pressure foot.

6.5 *Test Specimen Frame*—A frame for each test specimen made from a straight length (approximately 1 m (39 in.)) of round Nichrome AWG No. 14 wire. Bend the wire to form a rectangle having inside dimensions of 150 by 300 mm (6 by 12 in.). Overlap the ends of the wire approximately 50 mm (2 in.) at one corner. Attach the specimen to the frame.

6.6 *Test Fixture for Aging Specimen*—A suitable fixture for mounting the specimen frames a minimum of 25 mm (1 in.) apart so that they are secured at top and bottom.

6.7 *Dipping Apparatus*—An apparatus capable of removing the specimen from the varnish at the rate of 100 mm (4 in.)/min.

7. Safety Precautions

7.1 It is unsafe to use varnish at temperatures above the flash point without adequate ventilation, especially if the possibility exists that flames or sparks are present. Store varnish in sealed containers.

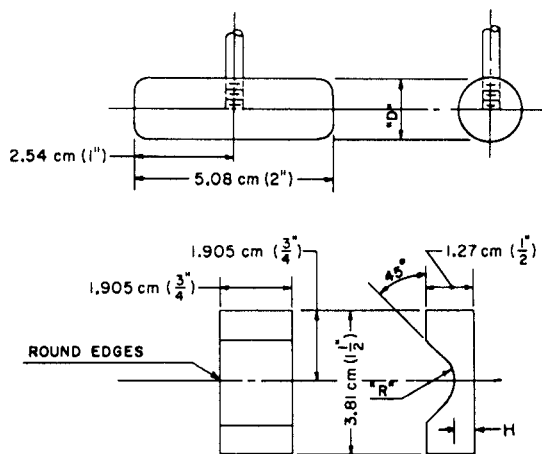

Insulation Thickness		Dimension R		Dimension H		Dimension D	
cm	in.	cm	in.	cm	in.	cm	in.
0.018	0.007	0.455	0.179	0.815	0.321	0.871	0.344

Tolerance for R and D = 0.003 cm (0.001 in.)

Tolerance for H = 0.005 cm (0.002 in.)

FIG. 1 Single-Shot Curved Electrode Details