



Designation: C 761 – 04

# Standard Test Methods for Chemical, Mass Spectrometric, Spectrochemical, Nuclear, and Radiochemical Analysis of Uranium Hexafluoride<sup>1</sup>

This standard is issued under the fixed designation C 761; the number immediately following the designation indicates the year of original adoption or, in the case of revision, the year of last revision. A number in parentheses indicates the year of last reapproval. A superscript epsilon ( $\epsilon$ ) indicates an editorial change since the last revision or reapproval.

*This standard has been approved for use by agencies of the Department of Defense. 4*

## 1. Scope

1.1 These test methods cover procedures for subsampling and for chemical, mass spectrometric, spectrochemical, nuclear, and radiochemical analysis of uranium hexafluoride ( $\text{UF}_6$ ). Most of these test methods are in routine use to determine conformance to  $\text{UF}_6$  specifications in the Enrichment and Conversion Facilities.

1.2 The analytical procedures in this document appear in the following order:

NOTE 1—Subcommittee C26.05 will confer with C26.02 concerning the renumbered section in Test Methods C761 to determine how concerns with renumbering these sections, as analytical methods are replaced with stand-alone analytical methods, are best addressed in subsequent publications.

	Sections
Subsampling of Uranium Hexafluoride	7 – 10
Gravimetric Determination of Uranium	11 – 19
Titrimetric Determination of Uranium	20
Preparation of High-Purity $\text{U}_3\text{O}_8$	21
Isotopic Analysis	22
Isotopic Analysis by Double-Standard Mass-Spectrometer Method	23 – 29
Determination of Hydrocarbons, Chlorocarbons, and Partially Substituted Halohydrocarbons	29–36
Atomic Absorption Determination of Antimony	36
Spectrophotometric Determination of Bromine	37
Titrimetric Determination of Chlorine	38–44
Determination of Silicon and Phosphorus	45–51
Determination of Boron and Silicon	52–59
Determination of Ruthenium	60
Determination of Titanium and Vanadium	61
Spectrographic Determination of Metallic Impurities	62
Determination of Tungsten	63
Determination of Thorium and Rare Earths	64–69
Determination of Molybdenum	70
Atomic Absorption Determination of Metallic Impurities	71–76
Impurity Determination by Spark-Source Mass Spectrography	77
Determination of Boron-Equivalent Neutron Cross Section	78
Determination of Uranium-233 Abundance by Thermal Ionization Mass Spectrometry	79
Determination of Uranium-232 by Alpha Spectrometry	80–86
Determination of Fission Product Activity	87

Determination of Plutonium by Ion Exchange and Alpha Counting	88–92
Determination of Plutonium by Extraction and Alpha Counting	93–100
Determination of Neptunium by Extraction and Alpha Counting	101–108
Atomic Absorption Determination of Chromium Soluble In Uranium Hexafluoride	109–115
Atomic Absorption Determination of Chromium Insoluble In Uranium Hexafluoride	116–122
Determination of Technetium-99 In Uranium Hexafluoride	123–131
Method for the Determination of Gamma-Energy Emission Rate from Fission Products in Uranium Hexafluoride	132
Determination of Metallic Impurities by ICP-AES	133–142
Determination of Molybdenum, Niobium, Tantalum, Titanium, and Tungsten by ICP-AES	143–152

1.3 *This standard does not purport to address all of the safety concerns, if any, associated with its use. It is the responsibility of the user of this standard to establish appropriate safety and health practices and determine the applicability of regulatory limitations prior to use. (For specific safeguard and safety consideration statements, see Section 6.)*

## 2. Referenced Documents

2.1 The following documents of the issue in effect on date of material procurement form a part of this specification to the extent referenced herein: <https://standards.ahp.org/standards/sist/23ab1e90c7c783f17/astm-c761-04>

### 2.2 ASTM Standards:<sup>2</sup>

- C 696 Test Methods for Chemical, Mass Spectrometric, and Spectrochemical Analysis of Nuclear-Grade Uranium Dioxide Powders and Pellets
- C 753 Specification for Nuclear-Grade, Sinterable Uranium Dioxide Powder
- C 787 Specification for Uranium Hexafluoride for Enrichment
- C 799 Test Methods for Chemical, Mass Spectrometric, Spectrochemical, Nuclear, and Radiochemical Analysis of Nuclear-Grade Uranyl Nitrate Solutions
- C 996 Specification for Uranium Hexafluoride Enriched to Less Than 5% <sup>235</sup>U
- C 1128 Preparation of Working Reference Materials for Use in the Analysis of Nuclear Fuel Cycle Materials

<sup>1</sup> These test methods are under the jurisdiction of ASTM Committee C26 on Nuclear Fuel Cycle and are the direct responsibility of Subcommittee C 26.05 on Methods of Test.

Current edition approved July 1, 2004. Published August 2004. Originally approved in 1973. Last previous edition approved in 2001 as C761 – 01.

<sup>2</sup> For referenced ASTM standards, visit the ASTM website, www.astm.org, or contact ASTM Customer Service at service@astm.org. For *Annual Book of ASTM Standards* volume information, refer to the standard's Document Summary page on the ASTM website.

- C 1219 Test Methods for Arsenic in Uranium Hexafluoride
- C 1233 Practice for Determining Equivalent Boron Contents of Nuclear Materials
- C 1267 Test Method for Uranium by Iron (II) Reduction in Phosphoric Acid Followed by Chromium (VI) Titration in the Presence of Vanadium
- C 1287 Test Method for Determination of Impurities in Uranium Dioxide by Inductively Coupled Plasma Mass Spectrometry
- C 1295 Test Method for Gamma Energy Emission from Fission Products in Uranium Hexafluoride<sup>2</sup>
- C 1344 Test Method for Isotopic Analysis of Uranium Hexafluoride by Single-Standard Gas Source Mass Spectrometer Method
- C 1346 Practice for Dissolution of UF<sub>6</sub> from P-10 Tubes
- C 1380 Test Method for the Determination of Uranium Content and Isotopic Composition of Isotope Dilution Mass Spectrometry
- C 1413 Test Method for Isotopic Analysis of Hydrolyzed Uranium Hexafluoride and Uranyl Nitrate Solutions By Thermal Ionization Mass Spectrometry
- C 1428 Test Method for Isotopic Analysis of Uranium Hexafluoride by Single-Standard Gas Source Multiple Collector Mass Spectrometer Method
- C 1429 Test Method for Isotopic Analysis of Uranium Hexafluoride by Double-Standard Multi-Collector Gas Mass Spectrometer
- C 1441 Test Method for the Analysis of Refrigerant 114, Plus Other Carbon-Containing and Fluorine-Containing Compounds in Uranium Hexafluoride via Fourier-Transform Infrared (FTIR) Spectroscopy
- C 1474 Test Method for Analysis of Isotopic Composition of Uranium in Nuclear-Grade Fuel Material by Quadrupole Inductively Coupled Plasma-Mass Spectrometry
- C 1477 Test Method for Isotopic Abundance Analysis of Uranium Hexafluoride by Multi-collector Inductively Coupled Plasma-Mass Spectrometry
- C 1508 Test Method for Determination of Bromine and Chlorine in UF<sub>6</sub> and Uranyl Nitrate by X-Ray Fluorescence
- D 1193 Specification for Reagent Water
- E 60 Practice for Photometric and Spectrophotometric Methods for Chemical Analysis of Metals
- E 115 Practice for Photographic Processing in Optical Emission Spectrographic Analysis
- E 130 Practice for Designation of Shapes and Sizes of Graphite Electrodes
- 2.3 American Chemical Society Specification:**  
Reagent Chemicals<sup>3</sup>
- 2.4 Other Specifications:**  
Uranium Hexafluoride: Base Charges, Use Charges, Special Charges, Table of Enriching Services, Specifications, and Packaging<sup>4</sup>

- USEC 651 Good Handling and Practices for UF<sub>6</sub><sup>4</sup>
- ANSI N 14.1
- ISO 7195

### 3. Significance and Use

3.1 Uranium hexafluoride is a basic material used to prepare nuclear reactor fuel. To be suitable for this purpose the material must meet criteria for uranium content, isotopic composition, metallic impurities, hydrocarbon and halo-hydrocarbon content. These test methods are designed to determine whether the material meets the requirements described in Specification C 787.

### 4. Reagents

4.1 *Purity of Reagents*—Reagent grade chemicals shall be used in all procedures. Unless otherwise indicated, all reagents shall conform to the specifications of the Committee on Analytical Reagents of the American Chemical Society, where such specifications are available.<sup>5</sup> Other grades may be used, provided that it is first established that the reagent to be used is of sufficiently high purity to permit its use without lessening the accuracy of the determination.

4.2 *Purity of Water*—Unless otherwise indicated, references to water shall mean reagent water conforming to Specification D 1193.<sup>6</sup>

### 5. Rejection

5.1 Rejection or acceptance criteria are described in Specifications C 787 and C 996.

### 6. Safety Considerations

6.1 Since UF<sub>6</sub> is radioactive, toxic, and highly reactive, especially with reducing substances and moisture (see Uranium Hexafluoride: Handling Procedures and Container Criteria), appropriate facilities and practices for sampling and analysis must be provided.

#### 6.2 Committee C-26 Safeguards Statement:

6.2.1 The material (uranium hexafluoride) to which these test methods apply, is subject to nuclear safeguards regulations governing its possession and use. The following analytical procedures in these test methods have been designated as technically acceptable for generating safeguards accountability measurement data: Gravimetric Determination of Uranium; Titrimetric Determination of Uranium; All Isotopic Analyses.

6.2.2 When used in conjunction with appropriate certified Reference Materials (CRMs), these procedures can demonstrate traceability to the national measurement base. However, adherence to these procedures does not automatically guarantee regulatory acceptance of the resulting safeguards measurements. It remains the sole responsibility of the user of these test methods to assure that its application to safeguards has the approval of the proper regulatory authorities.

<sup>3</sup> "Reagent Chemicals, American Chemical Society Specifications," Washington, DC. For suggestions on the testing of reagents not listed by the American Chemical Society, See "Reagent Chemicals and Standards," by Joseph Rosin, D. Van Nostrand Co., Inc., New York, NY, and the "United States Pharmacopeia."

<sup>4</sup> United States Department of Energy, Oak Ridge, TN 37830.

<sup>5</sup> The boldface numbers in parentheses refer to a list of references at the end of these test methods.

<sup>6</sup> Type 1 and 2 water have been found to be suitable.

## SUBSAMPLING OF URANIUM HEXAFLUORIDE (1, 2)<sup>5</sup>

### 7. Scope

7.1 This test method is applicable to the subsampling (3) of UF<sub>6</sub> from bulk sample containers into smaller containers suitable for laboratory analyses. The procedure includes sample filtration that facilitates determination of both soluble and insoluble chromium compounds.

### 8. Summary of Test Method

8.1 The UF<sub>6</sub> in the bulk sample container is liquefied and homogenized by vigorous shaking. The container is inverted and connected to the top of a heated vacuum-manifold system, and the subsample container is attached to the appropriate port of the system. The system is evacuated, and the liquid UF<sub>6</sub> is allowed to flow by gravity into the subsample container. Table 1 summarizes the purpose of various subsamplings.

8.2 If the determination of the volatile component of an impurity is needed (for example, chromium compounds), a total gas transfer may be necessary. In such case, the tared liquid UF<sub>6</sub> bulk sample container is connected to the top of the heated manifold without inversion, so that gaseous UF<sub>6</sub> is transferred.

### 9. Apparatus

9.1 *Hot Water Bath.*

9.2 *Heated Vacuum Manifold with Liquid Nitrogen Cold Trap* (Fig. 1).

9.3 *Gaseous Isotopic Abundance Sample Tube* (Fig. 2).

9.4 *Polychlorotrifluoroethylene Sample Tube* (Fig. 3).

9.5 *Polychlorotrifluoroethylene Knockout Cylinder* (Fig. 4), closed with a Cajon<sup>7</sup> M-16 VCR-1 female nut and an M-16 VCR-4 male nut, or equivalent.

9.6 *Nickel Filter Disk*, porous, 2- $\mu$ m, free of chromium (Fig. 5). Mott Metallurgical Corp. or equivalent.<sup>8</sup>

9.7 *Gas Sample Cylinder*, 0.5 L.

### 10. Procedure

10.1 *System Preparation:*

10.1.1 Place the bulk sample container in a water bath at 90°C  $\pm$  3°C.

10.1.2 After the UF<sub>6</sub> has been liquefied, remove the container from the bath, shake to homogenize the sample, and connect it at the top of the vacuum-manifold system shown in Fig. 1. The container will be inverted if liquid UF<sub>6</sub> must be subsampled.

10.1.3 When a liquid subsample is required for uranium analysis or chemical impurity (metal, halogen), and TIMS isotopic analysis, connect a tared polychlorotrifluoroethylene sample tube at the Cajon connection at the bottom of the system. If this subsample is not required, attach a blind fitting at this point.

10.1.4 When a liquid subsample is required for gaseous isotopic analysis or all gas carbon compound determination,

<sup>7</sup> Brand names mentioned in this procedure are intended to be typical, not limiting. Another brand of comparable characteristics could perform equally well.

<sup>8</sup> The filter disk should weigh approximately 1 g and be 16 mm in diameter by 0.6 mm thick. It should be of nickel powder produced from carbonyl nickel and formed by the no pressure sintering method in graphite or ceramic molds.

**TABLE 1 Subsamples for UF<sub>6</sub> Specification Analyses**

2S Cylinder Sample from Shipping Cylinder					
1 Nickel Filter Disk (Fig. 5)	1 Fluoroethene Tube	1 Fluoroethene Tube Knockout Cylinder	1 Fluoroethene Sample Tube	1 Disposable	1 Gas Cylinder
20 g UF <sub>6</sub>	8 g UF <sub>6</sub>	2 g UF <sub>6</sub>	B	4 g UF <sub>6</sub>	< 75 mm Pressure
Dissolved Disk Solution	g U/g	Hydrolyzed in Fresh NH <sub>3</sub> Solution		<sup>235</sup> U	Hydrocarbons, Chlorocarbons, Partially-Substituted Halohydrocarbons
Soluble and Insoluble Cr	Al, Ba, Be, Bi, Ca, Cd, Co, Cr, Cu, Fe, Li, Mg, Mn, Na, Ni, Pb, Sn, and Zn	B and Si		<sup>234</sup> U <sup>a</sup>	
				<sup>236</sup> U <sup>a</sup>	
	1 g U in Solution <sup>a</sup>	10 g U in Solution	40 g U in Solution		60 g U in Solution <sup>a</sup>
	<sup>233</sup> U	Br and Cl	Nb, Ta, Ti, Mo, W, V, Zr Sb and P Ru Th, Dy, Gd, Sm Sr and K		<sup>232</sup> U Pu, Np Fission Product: $\gamma$ $\beta$

<sup>a</sup> Required only for reactor returns.

B 100 g UF<sub>6</sub> hydrolyzed in (1 + 4) HNO<sub>3</sub> and 100 g UF<sub>6</sub> hydrolyzed in ice water for <sup>235</sup>U, Br and Cl.

TABLE 1 – Subsamples for UF<sub>6</sub> Specification Analyses

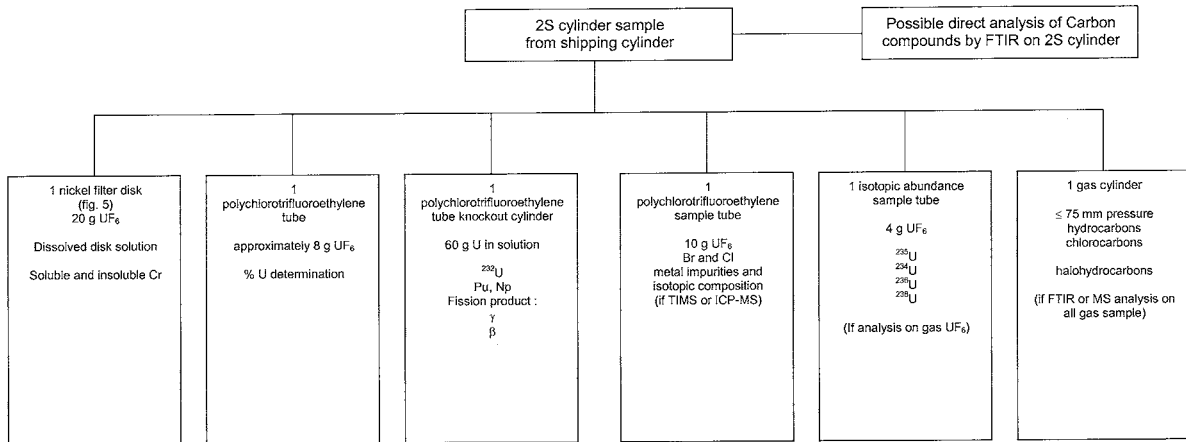

NOTE 1—All lines are 3/8-in. (9.5-mm) Monel tubing.

NOTE 2—All valves are Monel diaphragm-type valves.

NOTE 3—The valves and lines are wrapped with heating tape to maintain a system temperature of about 80°C.

NOTE 4—Valve 2 is a 3-way valve modified to make it a 4-way valve. When the valve is closed, the polychlorotrifluoroethylene tube is isolated from the system, but the lines from Valve 1 to Valve 3 and to the bulk container are open.

FIG. 1 System for Sampling Liquid UF<sub>6</sub> from Small Containers

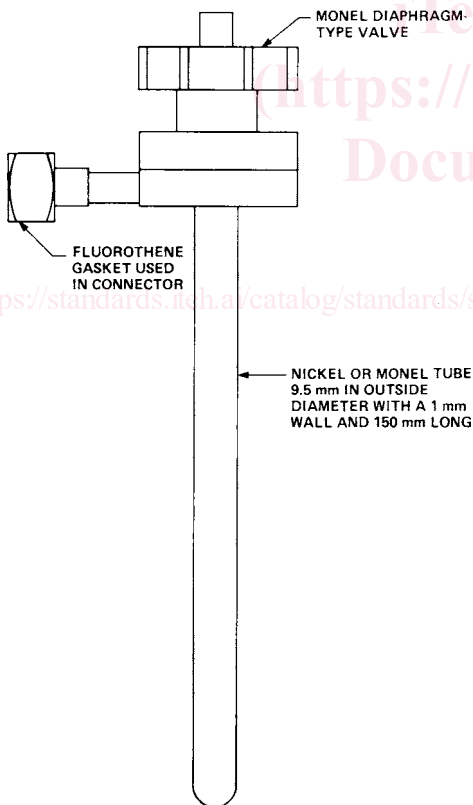

FIG. 2 Isotopic Abundance Sample Tube

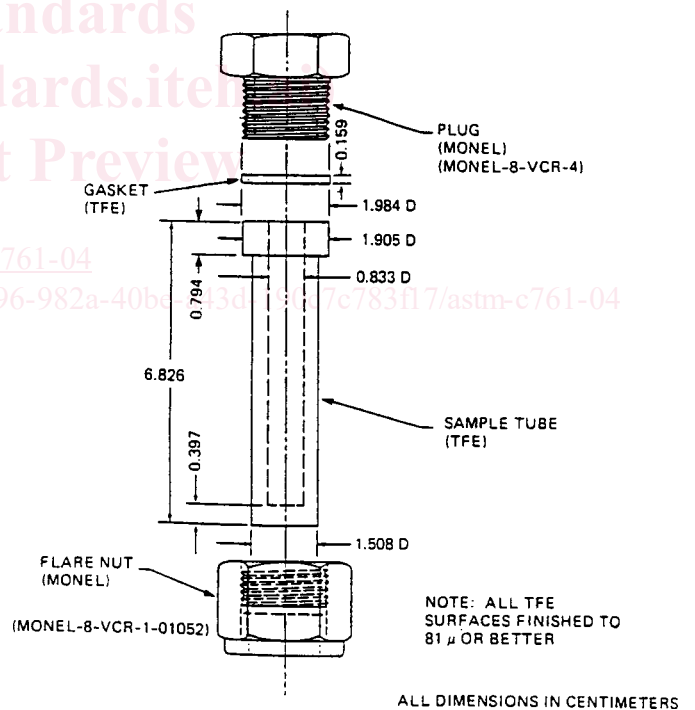

FIG. 3 Small TFCE Sample Tube

attach a tared isotopic abundance sample tube to the sample tube connection. If a subsample is not required, attach a cap at this point.

10.1.5 When a total gas UF<sub>6</sub> transfer is necessary, connect the UF<sub>6</sub> bulk container without inversion. Attach a polychlo-

rototrifluoroethylene knockout cylinder at the tube connection and attach a cap at the fitting for isotopic abundance sample tube.

10.1.6 Close Valve 4, then evacuate the entire system, except for the UF<sub>6</sub> bulk sample container.

10.2 Sample Transfer to the polychlorotrifluoroethylene Tube:

10.2.1 Close Valves 1, 2, and 3.

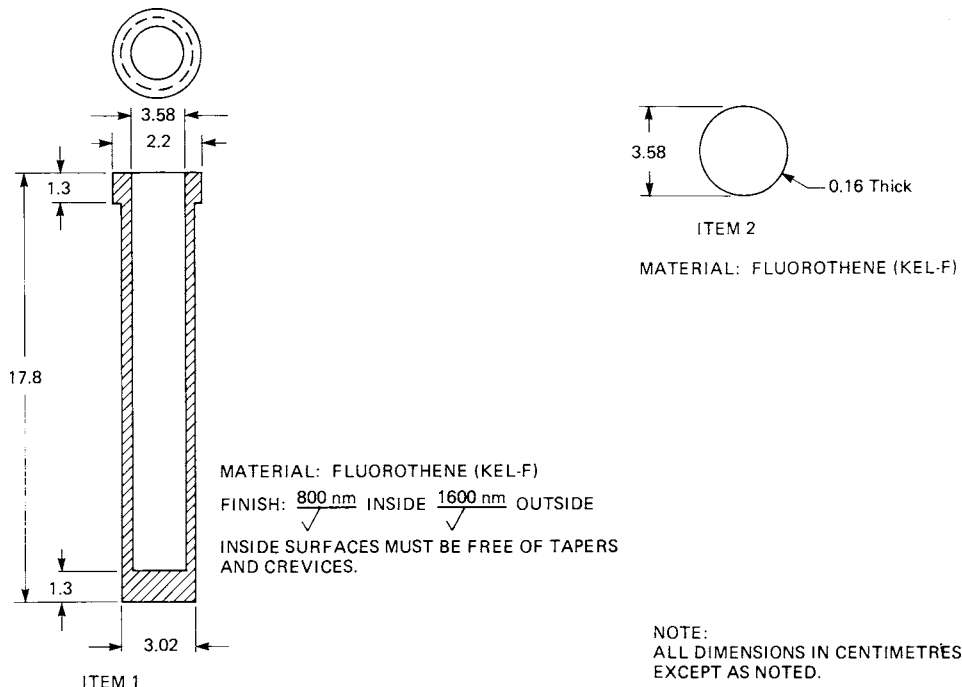

FIG. 4 polychlorotrifluoroethylene Knockout Cylinder

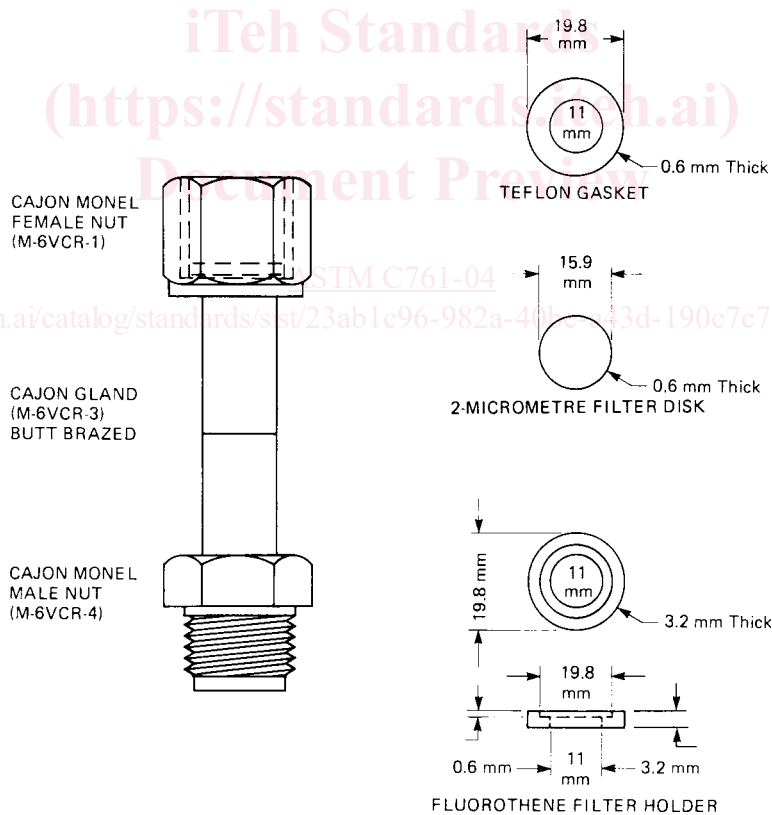

FIG. 5 Filter Disk Unit

10.2.2 To remove solid impurities, which may be present in the bulk-container valve, open that valve and then close it quickly. Transfer this flush aliquot of liquid  $\text{UF}_6$  to a polychlorotrifluoroethylene sample tube, as described below, and discard.

10.2.3 Open the bulk-container valve; then open Valve 2 slowly, allowing liquid  $\text{UF}_6$  to flow into the polychlorotrifluoroethylene tube. When the tube is half full of liquid  $\text{UF}_6$ , close Valve 2.

10.2.4 Close the bulk-container valve.



10.2.5 Open Valve 3 to remove UF<sub>6</sub> from the system. Open Valve 1 to ensure that the system is evacuated.

10.2.6 Close Valve 3.

10.2.7 Immerse the polychlorotrifluoroethylene tube in liquid nitrogen for 6 min.

10.2.8 Open Valve 2 to ensure that the sample does not exert a detectable vapor pressure.

10.2.9 Close Valve 5.

10.2.10 Open Valves 3 and 4, and admit dry nitrogen or dry air until a pressure slightly above 1 atm is reached.

10.2.11 Disconnect the polychlorotrifluoroethylene tube, seal with a polychlorotrifluoroethylene gasket and a Monel plug, and weigh the tube assembly.

10.2.12 Cap the manifold port and close Valves 2 and 4.

10.2.13 For metals, halogens, or isotopic analysis, proceed to the hydrolysis of the UF<sub>6</sub>.

10.2.13.1 Prepare chilled distilled water. Pour the water into a clean 500 mL polyethylene bottle. Use this water to prepare a solution of 0.1gU/g of solution.

10.2.13.2 Cool the polychlorotrifluoroethylene tube in liquid N<sub>2</sub> for 15 minutes. Remove the metal fittings and drop the tube in the water.

10.3 *Sample Transfer to a gaseous Isotopic Abundance Tube:*

10.3.1 Open Valves 1, 3, and 5, as well as the isotopic abundance tube valve, to evacuate the tube.

10.3.2 Close Valves 1, 2, and 3.

10.3.3 Immerse the lower half of the metal isotopic abundance tube, as shown in Fig. 2, in liquid nitrogen for 1 or 2 min. Immerse plastic tubing in ice water and observe desublimed UF<sub>6</sub>.

10.3.4 Remove the liquid nitrogen or ice water and allow frost to accumulate on the tube.

10.3.5 Open the bulk-container valve and then close.

10.3.6 Open Valve 1 slowly, and observe melting of the frost as the UF<sub>6</sub> flows into the tube. As soon as the frost disappears, close the isotopic abundance tube valve.

10.3.7 Open Valve 3 to remove the UF<sub>6</sub> from the manifold.

10.3.8 Close Valve 5 and open Valve 4 to admit dry nitrogen or dry air until a slight positive pressure is reached. Then close Valve 4.

10.4 *Sample Preparation for Soluble and Insoluble Chromium in UF<sub>6</sub>:*

10.4.1 Attach the porous nickel filter unit with a weighed 2- $\mu$ m filter, as shown in Fig. 5, to the bottom port of the vacuum manifold, and attach a tared polychlorotrifluoroethylene tube to the bottom of the filter unit.

10.4.2 Transfer 15 to 20 g of liquid UF<sub>6</sub> through the filter to the polychlorotrifluoroethylene sample tube, as in 10.2.3 through 10.2.12.

10.4.3 Remove the porous nickel filter and dissolve it in 10 mL of 1.42 sp gr HNO<sub>3</sub>.

10.4.4 Submit the dissolved filter solution for analysis of chromium insoluble in UF<sub>6</sub> and the filtered UF<sub>6</sub> in the polychlorotrifluoroethylene sample tube for chromium soluble in UF<sub>6</sub>.

10.5 *Sample Transfer to polychlorotrifluoroethylene Knockout Cylinder:*

10.5.1 Attach the polychlorotrifluoroethylene knockout cylinder, as shown in Fig. 4, to the bottom port of the manifold with a Cajon M-16 VCR-1 female nut, an M-16 VCR-4 male nut, and an M-16 VCR-3 gland.

10.5.2 Transfer approximately 50 to 200 g of liquid UF<sub>6</sub> to a tared polychlorotrifluoroethylene knockout cylinder, as in 10.2.3 through 10.2.12, except that in 10.2.7, the knockout cylinder is immersed in liquid nitrogen for 15 min.

10.5.3 Allow the knockout cylinder to warm to ambient temperature and then weigh to the nearest gram.

10.5.4 Freeze the knockout cylinder in liquid nitrogen for 15 min, and remove the metal fittings and cover gasket. Transfer the sample to a tared, 2-L polypropylene beaker chilled in ice water, by inverting the knockout cylinder over the beaker and rapping the bottom of the knockout cylinder with a rubber mallet.

10.5.5 Immediately add chilled distilled water, to form a solution of approximately 0.1 g U/g of solution.

10.5.6 Allow the solution to reach ambient temperature while stirring periodically with a polypropylene stirring rod until all of the solid has dissolved.

10.5.7 Weigh the solution and determine the uranium concentration per gram of solution.

10.5.8 Dispense aliquots of the solution for analysis according to Table 1.

10.6 *Sample Transfer for All Gas Carbon Determination:*

10.6.1 Attach a 2S cylinder to the fitting for the spectrometer isotopic abundance tube (Fig. 1).

10.6.2 Open Valves 1, 3, and 5 and the gas sample cylinder valve, and evacuate the manifold and sample cylinder.

10.6.3 Close Valve 3.

10.6.4 Slowly open the bulk-sample container valve to admit UF<sub>6</sub> until a pressure of 25 mm is reached in the sample cylinder. Close the bulk-sample container valve.

10.6.5 Open Valve 3 and evacuate the manifold and sample cylinder.

10.6.6 Close Valve 3.

10.6.7 Slowly open the bulk-sample container valve to admit UF<sub>6</sub> until a pressure of 75 mm is reached in the sample cylinder.

10.6.8 Close the gas sample cylinder valve and open Valve 3 to evacuate the manifold.

10.6.9 Close Valve 5, open Valve 4, to bring the manifold to atmospheric pressure and remove the bulk-sample container from the manifold.

10.6.10 Plug the bulk-sample container port on the manifold, close all valves, and remove the gas sample cylinder.

10.7 *Total UF<sub>6</sub> Gas Transfer:*

10.7.1 Immerse the bottom of the Knockout cylinder in liquid nitrogen for 15 min.

10.7.2 Close valve 3 and 5 and then open the bulk container valve. The pressure will increase due to the flow the UF<sub>6</sub> being drawn into the manifold.

10.7.3 Wait until the pressure drops back to its original value, which will indicate a total transfer of the gaseous UF<sub>6</sub> in the knockout cylinder.

NOTE 2—If the pressure does not drop, it may be due to frozen UF<sub>6</sub> in the top of the knockout cylinder. In that case remove the liquid nitrogen

from the knockout cylinder and heat the knockout cylinder until the UF<sub>6</sub> drops. Replace the liquid nitrogen container

10.7.4 Close valve 2 and open valves 3 and 5 to evacuate the UF<sub>6</sub> in the manifold. Open valve 4 to fill manifold with N<sub>2</sub>.

10.7.5 Disconnect and weigh the UF<sub>6</sub> bulk container. Compare the tare weight in order to ensure that a total UF<sub>6</sub> transfer was performed from the mother container to the knockout cylinder. If not, reconnect the mother container and proceed from 10.7.2.

10.7.6 Proceed according to 10.5.4 to hydrolyse the UF<sub>6</sub> in the knockout cylinder.

## GRAVIMETRIC DETERMINATION OF URANIUM

### 11. Scope

11.1 Test method C 1346 is applicable to the hydrolysis of uranium hexafluoride in polychlorotrifluoroethylene (P10) tubes. The following test method is then applicable to the direct gravimetric determination of uranium.

### 12. Summary of Test Method

12.1 A sample of uranium hexafluoride is weighed, cooled in liquid nitrogen, and hydrolyzed with water. The uranyl fluoride solution produced is evaporated to dryness and converted to uranouranic oxide by pyrohydrolysis. The uranium content is determined from the weight of the uranium oxide after correcting for stoichiometry based on isotopic content, ignition conditions, and nonvolatile impurities (4-7).

### 13. Interferences

13.1 Nonvolatile impurities affect the accuracy of the method and must be measured by spectrographic analysis with corrections applied.

### 14. Apparatus

14.1 *Polytrifluorochloroethylene (TFCE) Sample Tube, TFCE Gasket, Flare Nut, and Plug*, see Fig. 3.

14.2 *Platinum Boat and Cover*—The cover should be platinum gauze (52 mesh) and shaped to cover the boat (Fig. 6).

14.3 *Muffle Furnace*, must be capable of operating continuously at 875°C and maintain this temperature within ±25°C. The furnace shall be equipped with a steam supply that is passed through a tube furnace to preheat the steam to 875°C.

14.4 *Tube Furnace*, must be capable of operating continuously at 875°C and maintain this temperature within 25°C.

14.5 *Infrared Heat Lamps*, 250 watts.

14.6 *Analytical Balance*.

14.7 *Vacuum Oven*.

14.8 *Dewar Flask*, stainless steel.

14.9 *Spatula*, platinum.

14.10 *TFCE Rod*, 120 mm long and 1.6 mm in diameter.

14.11 *Forceps*, platinum tipped.

14.12 *Jig*, suitable for holding the TFCE sample tube so that it can be opened with a wrench.

14.13 *Box Wrench*, to fit sample tube plug.

14.14 *Beaker*, stainless steel, 125 mL capacity.

### 15. Reagents

15.1 *Liquid Nitrogen*.

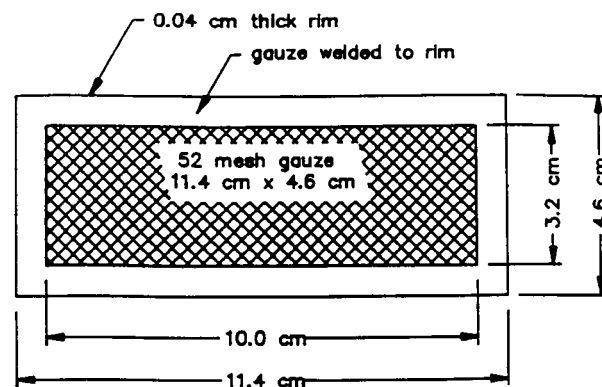

Cover

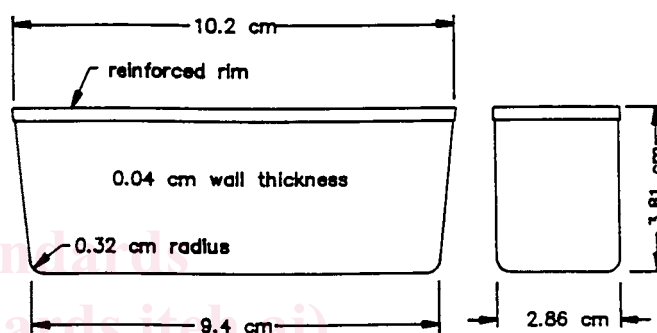

Boat

FIG. 6 Platinum Boat and Cover

15.2 *Nitric Acid* (sp gr 1.42)—concentrated nitric acid (HNO<sub>3</sub>).

15.3 *Nitric Acid (4M)*—Mix 500 mL of concentrated HNO<sub>3</sub> with 1500 mL of distilled water.

15.4 *Detergent*.

### 16. Sampling

16.1 A UF<sub>6</sub> sample is taken as described in 9.2.

### 17. Procedure

17.1 Inspect the TFCE sample tube for leaks.

NOTE 3—An indication of a leak is a yellow-green residue on the flare nut and cap or a yellow discoloration in the tube. Discard the sample if a leak is indicated.

17.2 Allow the sample tube to stand overnight in the laboratory.

17.3 Wipe the sample tube with a lint-free tissue to remove any moisture or foreign material that might be adhering.

17.4 Weigh the sample tube to the nearest 0.1 mg.

17.5 Heat the platinum boat and screen in the pyrohydrolysis furnace at 875°C for 20 min.

17.6 Cool the platinum boat and store in a desiccator for 40 min. Weigh the boat and screen to the nearest 0.1 mg.

17.7 Freeze the sample by immersing the sample tube in liquid nitrogen for 10 min.

17.8 Add enough chilled water to the tared platinum boat to immerse the sample tube (about 50 mL).

17.9 Place the sample tube in the jig and loosen the plug with the box wrench.

17.10 Remove the sample tube from the jig and unscrew the plug while holding the sample tube in an upright position.

17.11 Remove the flare nut from the sample tube and immerse the tube and gasket in the chilled water in the tared platinum boat.

17.12 Let the gasket remain in the chilled water about 30 min.

17.13 Remove the gasket with the forceps and rinse well with deionized water into the boat.

17.14 Place the plug-nut assembly and gasket into a stainless steel beaker for drying.

17.15 Allow the tube to remain in the water until the UF<sub>6</sub> has been hydrolyzed (2 to 4 h).

17.16 Remove the tube from the sample solution by inserting the TFCE rod or platinum spatula into the tube and lifting directly above the boat.

17.17 Rinse the sample tube with deionized water into the boat using extreme care to prevent splashing.

17.18 Cover the sample boat containing the UO<sub>2</sub>F<sub>2</sub> solution with the matching cover shown in Fig. 6. Place under the infrared head lamps and evaporate to dryness for 16 h.

17.19 Shake the excess water from the sample tube and place in the stainless beaker containing the plug-nut assembly and gasket.

17.20 Dry the sample tube parts in the vacuum oven at 80°C and 29 in Hg for 2 h.

17.21 Allow the unassembled parts to sit in the room overnight.

17.22 Assemble the empty sample tube and weigh to the nearest 0.1 mg.

17.23 Disassemble the sample tube and soak the tube and gasket in 4M HNO<sub>3</sub> at 75° to 80°C for 1 h.

17.24 Rinse with deionized water and place in the stainless steel beaker.

17.25 Clean the metal parts with detergent and rinse with deionized water and acetone.

17.26 Place the metal parts to the stainless steel beaker and dry all parts in the vacuum oven at 80°C and 29 in Hg overnight.

17.27 Reassemble the sample tube for the next sample.

17.28 Set the temperatures of the furnace and tube furnace at 875°C.

17.29 Establish a steam flow to the furnace equal to 1 L of water per hour.

17.30 Place the boat into the furnace with the platinum cover on the boat and pyrohydrolyze the sample for 1 h.

17.31 Remove the boat from the furnace, cool, and place in a desiccator while still warm.

17.32 Desiccate the sample for 1 h and weigh quickly to the nearest 0.1 mg.

17.33 Transfer a portion of the U<sub>3</sub>O<sub>8</sub> residue to a vial and submit for spectrographic analysis to determine the weight of nonvolatile impurities.

17.34 Place the platinum boat in hot 4M HNO<sub>3</sub> for 3 to 4 h and rinse with deionized water acetone.

## 18. Calculation

18.1 Calculate the weight fraction of uranium in the sample as follows:

$$\text{gU/g UF}_6 = (A - (AB))(\text{Gravimetric Factor})/W \quad (1)$$

where:

*Gravimetric Factor* = gU/g U<sub>3</sub>O<sub>8</sub> which varies with isotopic composition. Theoretical stoichiometry for U<sub>3</sub>O<sub>8</sub> cannot be assumed and the actual gU/g U<sub>3</sub>O<sub>8</sub> must be established by potentiometric titration (4–7). (Tri-diffusion plant committee with DOE approval has established 0.8479 g U/g U<sub>3</sub>O<sub>8</sub> by titration as the factor for natural uranium,

*A* = grams of U<sub>3</sub>O<sub>8</sub> from the pyrohydrolysis of UO<sub>2</sub>F<sub>2</sub>,

*B* = grams of impurity metal oxides per gram of U<sub>3</sub>O<sub>8</sub>,

*W* = corrected sample weight in grams.

The correction is for the combined effects of cover gas trapped over the UF<sub>6</sub> in the sample tube and the air buoyancy correction (8). The following equation has been determined for the sample tube in Fig. 3 and the subsampling conditions described in 10.2. The correction equation is applicable for sample weights in the range of 7 to 13 g.

$$W = (1.00047)x - 0.0058 \quad (2)$$

where:

*x* = observed UF<sub>6</sub> sample weight, g.

## 19. Precision and Bias

19.1 *Precision*—The precision within a laboratory and between laboratories was established by analyzing 15 samples at each laboratory. The sampling scheme is shown in Table 2. Within a laboratory, based on 15 measurements made on separate days the relative standard deviation is 0.021 %. The results from all the laboratories are shown in Table 3.

19.2 *Bias*—To establish an estimate of bias for the gravimetric method, a series of comparative analyses of UF<sub>6</sub> control batches were made using the gravimetric and potentiometric titration methods. The potentiometric titration was used as the reference method because the uranium was measured directly using NIST potassium dichromate.<sup>9</sup> The results are shown in Table 4.

## TITRIMETRIC DETERMINATION OF URANIUM

## 20. Scope

20.1 A sample of the U<sub>3</sub>O<sub>8</sub> produced by the hydrolysis of the UF<sub>6</sub> and ignition of the resulting UO<sub>2</sub>F<sub>2</sub> is analyzed according to Test Method C 1267.

<sup>9</sup> Standard reference material, now available as NIST SRM 136e.



TABLE 2 Interlaboratory Study<sup>A</sup>—Determination of Uranium in Uranium Hexafluoride

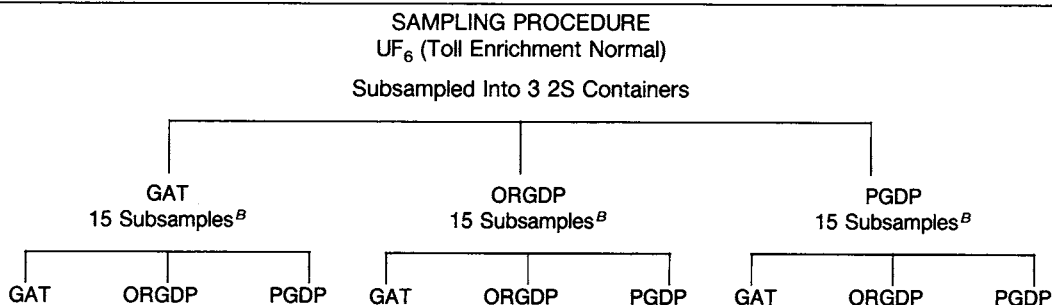

<sup>A</sup> Date of study—October 1983; Participating laboratories—Goodyear Atomic Corporation, Portsmouth, Ohio (GAT); Martin Marietta Energy Systems, Inc., Oak Ridge, Tennessee (ORGDP); Martin Marietta Energy Systems, Inc., Paducah, Kentucky (PGDP).  
<sup>B</sup> Five tubes analyzed at each laboratory.

TABLE 3 Results of Interlaboratory Study—U in UF<sub>6</sub>

Analysis Site %U in UF <sub>6</sub>		
GAT	ORGDP	PGDP
<i>Subsampled at GAT:</i>		
67.600	67.619	67.589
67.601	67.574	67.575
67.583	67.607	67.612
67.611	67.600	67.612
67.618	67.606	Sample Lost
<i>Subsampled at ORGDP:</i>		
67.614	67.580	67.611
67.611	67.621	67.598
67.587	67.600	67.501
67.599	67.606	67.610
67.617	67.596	67.624
<i>Subsampled at PGDP:</i>		
67.616	67.588	67.591
67.586	67.602	67.620
67.573	67.612	67.612
67.614	67.606	67.612
67.607		67.586
<i>Mean and Standard Deviation:</i>		
67.602 ± 0.014	67.601 ± 0.013	67.603 ± 0.014

## PREPARATION OF HIGH-PURITY U<sub>3</sub>O<sub>8</sub>

### 21. Scope

21.1 High purity U<sub>3</sub>O<sub>8</sub> can be prepared according to Preparation C 1128. High purity uranium is needed for a blank matrix for analyses using ICP-MS, ICP-AES, AA, XRF, and MS equipment.

## ISOTOPIC ANALYSIS

### 22. Scope

22.1 The isotopic composition can be determined on either gaseous UF<sub>6</sub> or on hydrolyzed UF<sub>6</sub>.

22.2 For gaseous UF<sub>6</sub>, a double standard single collector mass spectrometer method can be used (see sections 23 to 28). Test method C 1344 using single standard single collector mass spectrometer can also be used. For multi-collector instruments, test methods C 1428 and C 1429, using single or double standard can be used.

22.3 For hydrolyzed UF<sub>6</sub>, methods using Thermal Ionization Mass Spectrometry (TIMS) have been developed and can be used: test methods C 1413 and C 1380. Methods using ICP-MS can also be used depending on the required specifications: test methods C 1474 and C 1477.

## ISOTOPIC ANALYSIS BY DOUBLE-STANDARD MASS-SPECTROMETER METHOD

### 23. Scope

23.1 This test method is applicable to the determination of the isotopic composition of UF<sub>6</sub> samples. The test method as described is specific for the direct determination of the <sup>235</sup>U concentration of UF<sub>6</sub> samples having a <sup>235</sup>U content of 60 mol % or less. However, the test method is equally appropriate for the direct determination of any of the isotopes of uranium of any enrichment when suitable UF<sub>6</sub> isotopic standards are available. This test method is designed to minimize all known sources of analytical bias.

### 24. Summary of Test Method

24.1 The unknown sample and two standards whose <sup>235</sup>U contents bracket that of the unknown are introduced in sequence into the mass spectrometer, and measurements are made which are a function of the mol ratio of <sup>235</sup>U to the total of the other isotopes of uranium. These measurements together with the known composition of the standards permit calculation of the <sup>235</sup>U composition of the sample by linear interpolation (11 to 16).

24.2 The symmetrical, 6-entry sequence of sample-standard introductions is designed to minimize biases resulting from instrument drift, sample interaction or memory, and the non-linearity of the relationship between the measured resistance ratios and the true sample mol ratios. Corrections generally are not required for instrument memory.

### 25. Apparatus

25.1 *Mass Spectrometer* with the following features and capabilities (12, 14, 17):

**TABLE 4 Determination of Uranium in Uranium Hexafluoride—Comparison of Gravimetric and Potentiometric Titration Methods**

Control UF <sub>6</sub> Date <sup>A</sup>	Method	Number of Measurements	%Uranium		Bias Estimate <sup>B</sup>
			Mean	SD	
9/78	Gravimetric	24	67.610	0.009	-0.001
	Potentiometric Titration	9	67.611	0.015	
5/82–8/82	Gravimetric	30	67.596	0.010	-0.009
	Potentiometric Titration	8	67.605	0.011	
7/83–9/83	Gravimetric	25	67.610	0.006	+ 0.005
	Potentiometric Titration	8	67.605	0.010	

<sup>A</sup>Control UF<sub>6</sub> used in 9/78 was a different batch of material from that used in 1982 and 1983.

<sup>B</sup>Potentiometric titration results are used as the reference values for the bias estimates.

25.1.1 The instrument must have an electron bombardment ion source having an efficiency such that a sample flow rate of about 0.03 std ml of UF<sub>6</sub>/h will result in a total ion current for UF<sub>5</sub><sup>+</sup> ions of approximately 10<sup>-9</sup> A.

25.1.2 The sample inlet system must have a minimum of three points for attachment of samples, the necessary valves to evacuate the sample lines and admit the UF<sub>6</sub> into the ion source, and a variable leak to control the flow of UF<sub>6</sub> into the ion source.

25.1.3 A dual ion collector (18) must be used. The first detector, called the high-current collector, contains a central slit, preferably adjustable, to permit passage of 95 to 100 % of the ions of the <sup>235</sup>U isotope (mass 330). This detector intercepts ions of the other isotopes of uranium within a mass range of about 1.5 % of mass 330. The <sup>235</sup>U ions passing through the slit are intercepted by a second detector, called the low-current collector.

25.1.4 The measuring system must provide a precise null-balance measurement of the ratio of the ion signals from the low-current and high-current detectors. Such a system usually consists of two electrometer amplifiers, a constant-impedance ratio decade, a ratio recorder or two amplifiers, and a digital ratiometer. The sensitivity of the system should be such that a change of 1 × 10<sup>-15</sup> A ion current can be detected. An attenuation range of at least a factor of 100 should be provided for the low-current amplifier. If <sup>235</sup>U concentrations greater than 60 mol % are to be determined directly, a switch must be provided to reverse the amplifier leads to the ratio decade panel, and a similar attenuation range must be provided for the high-current amplifier. For those measurements the <sup>235</sup>U still passes through the slit, but the measurement is now a function of the ratio of the other isotopes to the <sup>235</sup>U isotope.

25.1.5 The resolving power of the instrument should be such that the <sup>235</sup>UF<sub>5</sub><sup>+</sup>-<sup>238</sup>UF<sub>5</sub><sup>+</sup> valley height should be less than 3.0 % of the <sup>235</sup>UF<sub>5</sub><sup>+</sup> peak height after the peak height has been normalized. The normalization consists of dividing the observed peak height by the sample <sup>235</sup>U concentration, expressed as a percentage. This resolution requirement should be met with the collector slit width adjusted to pass at least 95 % of the <sup>235</sup>U ion beam.

25.1.6 If the concentrations of the minor isotopes, <sup>234</sup>U and <sup>236</sup>U, are to be measured, the <sup>234</sup>UF<sub>5</sub><sup>+</sup>-<sup>235</sup>UF<sub>5</sub><sup>+</sup> valley should be less than 50 % of the <sup>234</sup>UF<sub>5</sub><sup>+</sup> peak height. To meet this requirement it will be necessary to narrow the collector slit width and reduce the ion beam transmission to 70 to 80 %.

## 26. Procedure

### 26.1 Sample Preparation:

26.1.1 A bias will be introduced into the analysis if impurities are present in the vapor phase of the sample or either standard. Prepare the UF<sub>6</sub> sample containers for the analysis as follows:

26.1.1.1 Attach the sample and standard containers to the sample inlet system. The low standard, A, should have a <sup>235</sup>U concentration lower than that of the sample, X, and the high standard, B, should have a concentration higher than the sample. The ratio of mol ratios of the standard pair should be about .

26.1.1.2 Open the appropriate valves to evacuate the sample lines of the inlet system.

26.1.1.3 After the system has been evacuated, open the valve on the sample container and then close quickly to vent the gas phase of the sample to the pumping system.

26.1.1.4 After the pumping system has had sufficient time to evacuate the vented gases, repeat 26.1.1.3.

26.1.1.5 Repeat 26.1.1.3 and 26.1.1.4 separately for the A and B standard containers.

26.1.1.6 Admit the B standard through the variable leak into the ion source for about 15 s, observe the ion source pressure, and remove the sample from the source.

26.1.1.7 Repeat 26.1.1.6 for the sample and for the A standard.

26.1.1.8 If the source pressure readings are the same, the samples are ready for the analysis (see 26.2).

26.1.1.9 If a high pressure is observed for one of the samples, immerse the sample container in a mixture of trichloroethylene and dry ice; open the container valve; and pump off the volatile impurities.

26.1.1.10 Close the container valve, allow the sample to reach ambient temperature, and repeat 26.1.1.6. If the source pressure reading is the same as the other samples, the samples are ready for the analysis (see 26.2).

26.1.1.11 If the pressure is still high, liquefy the UF<sub>6</sub> by heating the sample container to 70°C; then open the valve on the container and close quickly to vent the gas phase to the pumping system.

26.1.1.12 After the pumping system has had sufficient time to evacuate the vented gases, repeat 26.1.1.6. If necessary, repeat 26.1.1.9 or 26.1.1.11, or both, until no increase in pressure is observed.

### 26.2 Instrument Preparation:

26.2.1 Prepare the instrument for the analysis as follows:

26.2.1.1 Operate the appropriate valves to admit the low standard, A, through the variable leak into the ion source.

26.2.1.2 Adjust the mass spectrometer high voltage or magnet current, or both, to focus the  $\text{UF}_5^+$  ions on the upper detector plate.

26.2.1.3 Make a fine adjustment of the high-voltage or magnet current to focus the  $^{235}\text{U}$  ion beam (for samples containing 60 mol %  $^{235}\text{U}$  or less) of the  $\text{UF}_5^+$  ion group through the slit to the lower detector plate, while the other ions of the  $\text{UF}_5^+$  ion group are focused on the upper collector plate. This step, known as *peaking up*, is completed when the signal for the low-current collector plate is maximized.

26.2.1.4 Adjust the variable leak so that the flow of  $\text{UF}_6$  into the ion source produces the desired signal for the ions striking the upper collector plate. This ion current should be equivalent to approximately  $10^{-9}$  A.

26.2.1.5 Operate the valves to remove the flow of the A standard from the ion-source region, and evacuate the region for a period of 1 min or more.

### 26.3 Mass Spectrometer Measurements:

26.3.1 The sequence for the analytical determination during which the actual measurements are made is as follows: A, X, B, B, X, A, where A, X, and B represent a constant, precisely timed introduction of Standard A, Sample X, and Standard B, respectively. Each introduction is followed by a somewhat shorter, but precisely timed, period during which there is no flow of sample or standard material into the ion source. During each introduction of  $\text{UF}_6$  into the ion source, perform the following operations:

26.3.1.1 Regulate the intensity of the ions striking the upper collector plate to the desired level, and within as close a tolerance range as can be attained, by adjusting the variable leak to control the sample flow.

26.3.1.2 Adjust the high-voltage or magnet-current fine control to maximize the low-current detector signal; maintain the adjustment at this maximum value for the remainder of the timed introduction period, or sweep repeatedly across this maximum reading to obtain a series of scans of the peak maxima during the remainder of this period.

26.3.1.3 With the instrument peaked up, or while scanning the peak, obtain a reading while the electrometers for the two detecting plates are connected in a null-type measuring circuit. This reading is a function of the ratio of the number of ions striking the lower detector plate to the total number of ions striking the upper plate. Use only the data taken during the last half of the timed introduction period.

26.3.1.4 For each analytical sequence of A, X, B, B, X, A, obtain six ratio values, two for each standard and two for the sample. Average the two values obtained for each standard and the sample to obtain three ratio values designated  $R_A$ ,  $R_X$ , and  $R_B$  for each A, X, B, B, X, A sequence.

26.3.1.5 For samples in which the  $^{235}\text{U}$  content is greater than 60 mol %, reverse the amplifier leads to the ratio decade to obtain a null-balance measurement. The measurements are then a function of the ratio of the number of ions other than  $^{235}\text{U}$  to the number of  $^{235}\text{U}$  ions. As an alternative procedure, make the focus in 26.2.1.3 on the  $^{238}\text{U}$  ion beam instead of the  $^{235}\text{U}$  ion beam. This procedure will result in the determination of the weight percent  $^{238}\text{U}$ . To determine the  $^{235}\text{U}$  content, determine the minor isotopes independently, and subtract the

sum of the weight percent  $^{238}\text{U}$  and the weight percent of the minor isotopes from 100 to obtain the weight percent  $^{235}\text{U}$ .

26.3.1.6 The small residual bias associated with this test method is no larger than  $\pm 0.02$ , and even this may be corrected by making end-point determinations. The end-point controls are additional measurements with one of the standards, A or B, substituted for the unknown in the analytical sequence. Thus, for an end-point measurement, follow one of the sequences A, A, B, B, A, A, or A, B, B, B, B, A, and use the results to make corrections for residual bias in the measurements on the unknown.

## 27. Calculation

27.1 For uranium having a concentration of 50 mol %  $^{235}\text{U}$  or less, calculate the weight percent  $^{235}\text{U}$  as follows:

27.1.1 Calculate the ratio of differences,  $R_D$ , as follows:

$$R_D = (R_X - R_A)/(R_B - R_A) \quad (3)$$

where:

$R_X$  = average reading for sample entries,

$R_A$  = average reading for low-standard entries, and

$R_B$  = average reading for high-standard entries.

27.1.2 Calculate the sample weight ratio,  $H_X$ , using the linear interpolation, as follows:

$$H_X = R_D (H_B - H_A) + H_A \quad (4)$$

where:

$H_X$  = weight ratio of  $^{235}\text{U}$  to other isotopes in the sample,

$H_A$  = weight ratio of  $^{235}\text{U}$  to other isotopes in the low standard,

$H_B$  = weight ratio of  $^{235}\text{U}$  to other isotopes in the high standard, and

$R_D$  = value from Eq 3

27.1.3 Calculate the weight percent  $^{235}\text{U}$  ( $U_5$ ) in the sample as follows:

$$U_5 = 100 H_X / (100 + H_X) \quad (5)$$

27.2 For samples having a  $^{235}\text{U}$  concentration greater than 60 mol %, reverse the amplifier leads to the ratio decade, and obtain reciprocal readings which are a function of the ratio of the mols of other isotopes to the mols of  $^{235}\text{U}$ . Calculate the weight percent  $^{235}\text{U}$  as follows:

27.2.1 Calculate the ratio of differences,  $R_D$ , using Eq 1.

27.2.2 Calculate the reciprocal of the weight ratio,  $H_X$ , from the relationship:

$$1/H_X = R_D [(1/H_B) - (1/H_A)] + 1/H_A \quad (6)$$

27.2.3 Calculate the weight percent  $^{235}\text{U}$  in the sample, using Eq 5.

27.3 As an alternative method of analyzing samples having concentrations greater than 60 mol %  $^{235}\text{U}$ , determine the weight percents  $^{238}\text{U}$ ,  $^{234}\text{U}$ , and  $^{236}\text{U}$ . In each case pass the isotope of interest through the collector slit, and obtain measurements for the sample and the two bracketing standards. Use these measurements together with the known composition of the standards to calculate the sample composition by linear interpolation (Eq 4). The standard values used in the calculations are the weight ratios of  $^{238}\text{U}$  to the other isotopes,  $^{234}\text{U}$  to the other isotopes, or  $^{236}\text{U}$  to the other isotopes. Obtain the  $^{235}\text{U}$  composition by difference.