



Designation: B900 – 04

Standard Practice for Packaging of Copper and Copper Alloy Mill Products for U.S. Government Agencies¹

This standard is issued under the fixed designation B900; the number immediately following the designation indicates the year of original adoption or, in the case of revision, the year of last revision. A number in parentheses indicates the year of last reapproval. A superscript epsilon (ϵ) indicates an editorial change since the last revision or reapproval.

1. Scope*

1.1 This practice establishes requirements for packaging, packing, and marking intended to ensure proper and safe storage and transportation of copper and copper alloy mill products, both foreign and domestic, for direct shipment to government activities or shipment processed at a military activity or agency. This practice details the materials, methods, containers, and procedures for the preparation for shipment of copper and copper alloy mill products. Mill products wherein copper is the basic metal are within the scope of this practice. Commercial packaging establishes the minimum requirements that apply unless Level A or B packing is specified (see 6.1).

1.2 *Units*—The values stated in inch-pound units are regarded as standard. The SI values given in parentheses are mathematical conversions to SI units that are provided for information only and are not considered standard.

1.3 *This standard does not purport to address all of the safety concerns, if any, associated with its use. It is the responsibility of the user of this standard to establish appropriate safety and health practices and determine the applicability of regulatory limitations prior to use.*

2. Referenced Documents

2.1 ASTM Standards:²

- B846 Terminology for Copper and Copper Alloys
- D143 Test Methods for Small Clear Specimens of Timber
- D779 Test Method for Water Resistance of Paper, Paperboard, and Other Sheet Materials by the Dry Indicator Method
- D828 Test Method for Tensile Properties of Paper and Paperboard Using Constant-Rate-of-Elongation Apparatus³

¹ This practice is under the jurisdiction of ASTM Committee B05 on Copper and Copper Alloys and is the direct responsibility of Subcommittee B05.91 on Editorial and Publications.

Current edition approved Oct. 1, 2004. Published October 2004. Originally approved in 1999. Last previous edition approved in 1999 as B900–99. DOI: 10.1520/B0900-04.

² For referenced ASTM standards, visit the ASTM website, www.astm.org, or contact ASTM Customer Service at service@astm.org. For *Annual Book of ASTM Standards* volume information, refer to the standard's Document Summary page on the ASTM website.

³ Withdrawn. The last approved version of this historical standard is referenced on www.astm.org.

D1974 Practice for Methods of Closing, Sealing, and Reinforcing Fiberboard Boxes

D3951 Practice for Commercial Packaging

D4444 Test Method for Laboratory Standardization and Calibration of Hand-Held Moisture Meters

D5118/D5118M Practice for Fabrication of Fiberboard Shipping Boxes

D5168 Practice for Fabrication and Closure of Triple-Wall Corrugated Fiberboard Containers

D5330/D5330M Specification for Pressure-Sensitive Tape for Packaging, Filament-Reinforced

D6251/D6251M Specification for Wood-Cleated Panel-board Shipping Boxes

2.2 ANSI Standard:⁴

ANSI/ASQC Z1.4 Sampling Procedures and Tables for Inspection by Attributes

2.3 Federal Specifications:⁵

A-A-55057 Panels, Wood/Wood Base: Construction and Decorative

PPP-B-585 Boxes, Wood, Wirebound

PPP-B-587 Boxes, Wood, Wirebound Pallet Type

PPP-B-601 Boxes, Wood, Cleated-Plywood

PPP-B-621 Boxes, Wood, Nailed and Lock-Corner

PPP-B-1055 Barrier Material, Waterproofed, Flexible

PPP-D-705 Drum: Metal Shipping, Steel, (Over 12 and Under 55 Gallon)

PPP-D-723 Drums, Fiber

PPP-D-729 Drums: Metal, 55-Gallon (for Shipment of Non-corrosive Material)

2.4 Military Standard:⁵

MIL-STD-129 Marking for Shipment and Storage

2.5 Military Publication:⁵

MIL-HDBK-774 Palletized Unit Loads

3. Terminology

3.1 For definitions of terms related to copper and copper alloys, refer to Terminology B846.

3.2 *Definitions of Terms Specific to This Standard:*

⁴ Available from American National Standards Institute (ANSI), 25 W. 43rd St., 4th Floor, New York, NY 10036.

⁵ Available from Standardization Documents Order Desk, DODSSP, Bldg. 4, Section D, 700 Robbins Ave., Philadelphia, PA 19111-5098.

*A Summary of Changes section appears at the end of this standard.

3.2.1 *deckboard, n*—piece or pieces of lumber fastened at right angles to the stringers or skids of a pallet to form a load-bearing surface.

3.2.2 *gross weight, n*—the bare-item weight and the weight of all packaging and packing materials.

3.2.3 *interleaving, n*—the protective material placed between two adjacent pieces of metal.

3.2.4 *net weight, n*—the bare-item weight.

3.2.5 *nominal, adj*—the rough-sawn, commercial size designation for lumber common to the industry.

3.2.6 *packing; Level A*—the protection required to meet the most severe worldwide shipment, handling, and storage conditions.

3.2.6.1 *Discussion*—A Level A package must be capable of protecting material from effects of direct exposure to extremes of climate, terrain, and operational transportation environments.

3.2.7 *packing; Level B*—the protection required to meet moderate worldwide shipment, handling, and storage conditions.

3.2.7.1 *Discussion*—A Level B package must be capable of protecting material not directly exposed to extremes of climate, terrain, and operational transportation environments.

3.2.8 *packaging; commercial*—although not specifically defined by any government regulation or instruction, commercial packaging (preservation and packing) is understood to be those practices by manufacturers and contractors to protect and identify material and items packaged for retail and wholesale distribution purposes.

3.2.8.1 *Discussion*—Practice **D3951** provides guidance in the application of commercial packaging.

NOTE 1—It has been determined by joint DoD instructions that commercial, also in some areas addressed as industrial packaging, should only be used or specified when such packaging is known to satisfy the DoD needs. Such use should be determined before a contract for supplies is awarded or within the life cycle of the contract when substantial savings to the government may result. Commercial (industrial) packaging should not be specified where multiple shipments and handlings are anticipated or desired.

3.2.9 *skid, n*—one of a pair or series of parallel wood runners affixed to the underside of boxes, crates, or an item allowing entry of truck forks, or to facilitate sliding.

3.2.10 *sound woods, n*—wood free of any form of decay, incipient or advanced, and from insert holes.

3.2.11 *stringer, n*—a wooden member fastened at right angles to the load-bearing members of a pallet or the deckboard of a platform.

3.2.12 *sulfate paper, n*—wood-pulp paper made by the sulfate process.

4. Significance and Use

4.1 This practice is applicable to packaging of copper alloy mill products for shipment to agencies of the U.S. Government.

4.2 It covers packaging of rod, bar, shapes, plate, sheet, strip, foil, wire, flat wire, rolled bar, forgings, pipe, and tube products.

5. Classification

5.1 Shipping containers, for Levels A and B packing (see **7.6** and **7.8**), having common characteristics are as follows:

5.1.1 *Category 1*—Boxes, nailed wood, wire-bound wood, wood-cleated plywood, and wood cleated, veneer, paper overlaid (see **7.6.1**).

5.1.2 *Category 2*—Fiber and metal drums (see **7.6.2**).

5.1.3 *Category 3*—Pallets and pallet boxes (see **7.6.3**).

5.1.4 *Category 4*—Skidded lifts (see **7.6.4**).

5.1.5 *Category 5*—Hand bundles (see **7.6.5**).

5.1.6 *Category 6*—Secured lifts (without skids) (master bundles) (see **7.6.6**).

5.1.7 *Category 7*—Reels and spools (see **7.6.7**).

5.1.8 *Category 8*—Fiberboard boxes (see **7.6.8**).

5.1.9 *Category 9*—Special containers (see **7.6.9**).

6. Ordering Information

6.1 Orders for products shall specify the following packaging information:

6.1.1 ASTM designation and year of issue.

6.1.2 Fiberboard box, if other than Class 1 (see **7.6.8**).

6.1.3 Level of packaging and level of packing if other than commercial (see **7.4** and **7.6.9.1**).

6.1.4 Maximum gross weight of container (see **7.6.1.6-7.6.1.8**, **7.6.3** and **7.6.4**).

6.1.5 When palletized drums are required (see **7.8.2.7**).

6.1.6 When bare welding rod in wire form is required in fiber drums (see **7.8.2.7**).

6.1.7 When cores fitted with slinger ring attachment are required for shafting (see **7.8.2.7**).

6.1.8 When coiled wire is required in lighter or heavier net weight (see **7.8.2.7**).

6.1.9 When saddles are required (see **7.8.3.1**).

6.1.10 Special marking required (see **7.9**).

7. Detailed Requirements

7.1 *Options*—Unless otherwise specified, packaging and packing requirements selection shall be at the option of the contractor.

7.2 *Packaging and Packing Materials*—Materials not covered by applicable specifications or not specifically described herein shall be of the best commercial quality and suitable for the purpose intended.

7.2.1 *Packaging*—The use of packaging materials shall be in accordance with **7.8**.

7.3 *Level A:*

7.3.1 *Waterproof Barrier Materials*—The material shall consist of 100 % sulfate paper suitably coated or laminated to meet the following tensile-strength requirement when tested in accordance with Test Method **D828** and the following water-resistance requirement when tested in accordance with Test Method **D779**. If an asphalt laminate [base weight 30 lbs (13.6 kg) minimum] is used, the paper shall have a minimum base weight of 30 lbs per 500 sheets 24 by 36 in. (609.6 by 914.4 mm) (30-30-30-minimum).

Tensile strength per inch width (weaker direction)	15 lbs (16.8 kg)
Water resistance (dry indicator method)	10 h

7.3.2 Alternatively, waterproof-barrier materials in accordance with Specification PPP-B-1055 may be used at the contractor's option. All wrapping material in contact with bare metal surfaces shall be within the pH range from 5.0 to 10.0.

7.3.3 *Interleaving Paper*—Interleaving paper shall be anti-tarnishing, noncorrosive, uncreped paper of 10-lbs (4.54-kg) minimum base weight.

7.3.4 *Unit Containers*—Fiberboard boxes and closure methods used for packaging wire on spools, wire and tube in coils, or similar products shall be in accordance with Practices **D5118/D5118M** and **D1974**. Where specific container designs are not described by the applicable specification, the manufacturer's commercial practice shall apply.

7.4 *Commercial*—Unless Level A or B packing is specified (see 6.1), the following shall apply.

7.4.1 Packaging material(s) shall be sufficient to afford adequate protection against physical damage during shipment from the supply source to the first receiving activity for immediate use. This level may be in accordance with Practice **D3951** when such meets the requirements of this level.

7.5 *Packing (Levels A and B)*:

7.5.1 *Wood*—Requirements for wood for boxes, pallets, reels, and similar items with regard to species, quality, and dimensions shall be in accordance with Specification **PPP-B-621** except as modified in 7.5.1.2 and Tables 1-3.

7.5.1.1 *Seasoning*—The wood shall be seasoned to a moisture content not more than 18 % nor less than 12 %. At the time of inspection of containers, the moisture content of the wood shall not be less than 8 %. Wood for pallets shall be seasoned to a moisture content not more than 22 % for deck boards and 26 % for stringers.

7.5.1.2 *Plywood*—Plywood for boxes shall be in accordance with Type I or II, Class 2 of Specification **A-A-55057** for Level A packing, and Type III, Class 1 of Specification **A-A-55057** for Label B packing.

7.6 *Container Construction Packing and Securing Methods (Levels A and B)*:

7.6.1 *Category 1 Boxes*:

7.6.1.1 *Nailed Wood Boxes (All Groups of Wood)*—The construction and style of nailed wood boxes shall be in accordance with Figs. 1-6 and Tables 1-4. Side, top, and

bottom sections 9½ in. (241.3 mm) or less in width shall be made of one piece, whenever possible. Spliced boards, whenever necessary, on nailed wood boxes are permissible. The boards shall be butted and the splicing board shall extend on each side of the joint at least three times the width of the board being spliced. The splicing board shall equal the width and thickness of the boards being spliced. Nails shall be clinched.

7.6.1.2 *Skid (Runners)*—Except as specified herein, boxes having a gross weight exceeding 600 lbs (272 kg) shall be modified by the addition of nominal 2- by 4-in. (50.8- by 101.6-mm) skids positioned flatwise across the width of the box and located approximately 4 in. (101.6 mm) from the ends of the box. In attaching skids, nailing shall be through the bottom boards and into the skids. When longitudinal, as well as, girthwise straps are required, the skids shall be notched to permit passage of the straps between the skids and the bottom of the box. Skids are not required for boxes shipped on pallets, boxes in a skidded master shipping unit, or boxes 7 ft (2.13 m) or over in length.

7.6.1.3 *Thickness of Lumber*—The thickness of lumber for nailed wood boxes shall be in accordance with Tables 1-3.

7.6.1.4 *Nails*—The nails for nailed wood boxes shall be in accordance with Table 4.

7.6.1.5 *Strapping*—Nailed wood boxes shall be strapped with flat steel strap or round wire having a breaking strength equivalent to that of the flat steel strap. Strap placement shall be in accordance with Figs. 1-6, as applicable.

7.6.1.6 *Wirebound Boxes*—Wirebound boxes shall conform to Specification **PPP-B-585**, Class 3 use for Level A packing and Class 1 or 2 use for Level B packing. Unless otherwise specified (see 6.1), the gross weight of wirebound boxes shall not exceed the requirements of the box specification.

7.6.1.7 *Wood, Cleated-Plywood Boxes*—Wood cleated-plywood boxes shall be in accordance with Specification **PPP-B-601**, overseas type for Level A packing and domestic type for Level B packing. Unless otherwise specified (see 6.1), the gross weight shall not exceed, the weight limitations of the box specification.

7.6.1.8 *Wood, Cleated, Veneer, Paper-Overlaid Boxes*—Wood, cleated, veneer, paper-overlaid boxes shall conform to Specification **D6251/D6251M** Class 2 for Level A packing and

TABLE 1 Nailed Wood Boxes for Straight Lengths of Bar, Rod, Shafting, Shapes, Flat Wire, and Tubular Products

Weight of Content, lbs (kg)	Box Styles (See Figs. 1-6)	Minimum Sides Thickness, in. (mm)	Minimum Top and Bottom Thickness, in. (mm)	Ends		End Cleats ^A		Battens ^A	
				Styles 1 and 1A ^B	Styles 2, 4, 7, and 8 ^C	Styles 2, 4, 7, and 8		Styles 1A, 7, and 8	
				Minimum 1 or 2-Ply Thickness, in. (mm) ^D	Minimum 1-Ply Thickness, in. (mm)	Minimum Width, in. (mm)	Minimum Thickness, in. (mm)	Minimum Width, in. (mm)	Minimum Thickness, in. (mm)
Up to 280 (127)	1, 2, and 4	5/8 (15.8)	1/2 (12.7)	1 1/16 (27.0)	5/8 (15.8)	2 1/2 (63.5)	5/8 (15.8)
281 to 560 (128 to 254)	1, 2, and 4	5/8 (15.8)	5/8 (15.8)	1 1/16 (27.0)	5/8 (15.8)	2 1/2 (63.5)	5/8 (15.8)
561 to 1120 (255 to 508)	1 to 8	3/4 (19.1)	5/8 (15.8)	1 1/2 (38.1)	1 1/16 (27.0)	2 3/4 (69.9)	5/8 (15.8)	2 3/4 (69.9)	3/4 (19.1)
1121 to 2240 (509 to 1016)	1 to 8	1 1/16 (27.0)	3/4 (19.1)	1/2 (38.1)	1 1/16 (27.0)	2 3/4 (69.9)	1 1/16 (27)	2 3/4 (69.9)	3/4 (19.1)

^A Nails used for end cleats shall pass through the ends and be clinched to not less than 1/8 in. (3.175 mm). Nailing and clinching of battens shall be in such a manner as to prevent damage by protruding heads or points to the contents of the box.

^B Ends of boxes having a weight content exceeding 2000 lbs (907 kg) or ends of boxes exceeding 12 in. (305 mm) in depth shall be two-ply laminates of equal thickness with the grain reversed.

^C Styles 2, 4, 7, and 8 boxes shall not be required if the depth of the box is 10 in. (254 mm) or less.

^D Combined thickness of two-ply end; grain of separate piles reversed.

TABLE 2 Nailed Wood Boxes for Flat Straight Lengths of Plate, Sheet, and a Strip

Weight of Content, lbs (kg)	Box Styles (See Figs. 1-6)	Minimum Sides Thickness, in. (mm)	Minimum Top and Bottom Thickness, in. (mm)	Ends		End Cleats		Battens		
				Styles 1 and 1A ^A	Styles 2, 4, 7, and 8 ^B	Styles 2, 4, 7, and 8 ^C	Styles 1A, 7, and 8			
				Minimum 1 or 2-Ply Thickness, in. (mm) ^D	Minimum 1-Ply Thickness, in. (mm)	Minimum Width, in. (mm)	Minimum Thickness, in. (mm)	Minimum Width, in. (mm)	Minimum Thickness, in. (mm)	
Up to 280 (127)	1, 2, and 4	5/8 (15.8)	1/2 (12.7)	1 1/16 (27.0)	
281 to 560 (128 to 254)	1, 2, and 4	5/8 (15.8)	5/8 (15.8)	1 1/16 (27.0)	5/8 (15.8)	2 1/2 (63.5)	5/8 (15.8)	
561 to 1120 (255 to 508)	1 to 8	1 1/16 (27.0)	5/8 (15.8)	1 1/2 (38.1)	1 1/16 (27.0)	2 3/4 (69.9)	3/4 (19.1)	2 3/4 (69.9)	3/4 (19.1)	
1121 to 2240 (509 to 1016)	1 to 8	1 1/16 (27.0)	5/8 (15.8)	1 1/2 (38.1)	1 1/16 (27.0)	2 3/4 (69.9)	1 1/16 (27.0)	2 3/4 (69.9)	1 1/16 (27.0)	
2241 to 6000 (1017 to 2722)	1 to 8	1 1/2 (38.1)	1 1/16 (27.0)	2 (51)	1 1/16 (27.0)	2 3/4 (69.9)	1 1/16 (27.0)	2 3/4 (69.9)	1 1/16 (27.0)	
Boxes for Products Over 4 ft (1.22 m) in Length										
Up to 280 (127)	1 or 1A	5/8 (15.8)	1/2 (12.7)	1 1/16 (27.0)	2 1/2 (63.5)	5/8 (15.8)	
281 to 560 (128 to 254)	1 or 1A	1 1/16 (27.0)	5/8 (15.8)	1 1/16 (27.0)	2 1/2 (63.5)	5/8 (15.8)	
561 to 1120 (255 to 508)	1 or 1A	1 1/16 (27.0)	5/8 (15.8)	1 1/2 (38.1)	2 3/4 (69.9)	3/4 (19.1)	
1121 to 2240 (509 to 1016)	1 to 8	1 1/2 (38.1)	3/4 (19.1)	1 1/2 (38.1)	1 1/16 (27.0)	2 3/4 (69.9)	1 1/16 (27.0)	2 3/4 (69.9)	1 1/16 (27.0)	
2241 to 6000 (1017 to 2722)	1 to 8	1 1/2 (38.1)	1 1/16 (27.0)	2 (51)	1 1/16 (27.0)	2 3/4 (69.9)	1 1/16 (27.0)	2 3/4 (69.9)	1 1/16 (27.0)	

^A Ends of boxes having a weight content exceeding 2000 lbs (907 kg) or ends of boxes exceeding 12 in. (305 mm) in depth shall be two-ply laminates of equal thickness with the grain reversed.

^B Styles 2, 4, 7, and 8 boxes shall not be required if the depth of the box is 10 in. (254 mm) or less.

^C Nails used for end cleats shall pass through the ends and be clinched to not less than 1/8 in. (3.175 mm). Nailing and clinching of battens shall be in such a manner as to prevent damage by protruding heads or points to the contents of the box.

^D Combined thickness of two-ply end; grain of separate piles reversed.

TABLE 3 Nailed Wood Boxes for Wire (Round or Flat) on Spools or in Coils, Tubes in Coils, Circles and Disks, Sheet and Strip in Rolls, Forgings, or Similar Items

Weight of Content, lbs (kg)	Box Styles (See Figs. 1-6)	Minimum Sides Thickness, in. (mm)	Minimum Top and Bottom Thickness, in. (mm)	Ends		End Cleats		Battens	
				Styles 1 and 1A ^A	Styles 2, 4, 7, and 8 ^B	Styles 2, 4, 7, and 8 ^C	Styles 1A, 7, and 8		
				Minimum 1 or 2-Ply Thickness, in. (mm) ^D	Minimum 1-Ply Thickness, in. (mm)	Minimum Width, in. (mm)	Minimum Thickness, in. (mm)	Minimum Width, in. (mm)	Minimum Thickness, in. (mm)
Up to 280 (127)	1, 2, and 4	5/8 (15.8)	1/2 (12.7)	1 1/16 (27.0)	5/8 (15.8)	2 1/2 (63.5)	5/8 (15.8)
281 to 560 (128 to 254)	1, 2, and 4	5/8 (15.8)	5/8 (15.8)	1 1/16 (27.0)	5/8 (15.8)	2 1/2 (63.5)	5/8 (15.8)
561 to 1120 (255 to 508)	1 to 8	3/4 (19.1)	5/8 (15.8)	1 1/16 (27.0)	3/4 (19.1)	2 3/4 (69.9)	3/4 (19.1)	2 3/4 (69.9)	3/4 (19.1)
1121 to 2240 (509 to 1016)	1 to 8	3/4 (19.1)	5/8 (15.8)	1 1/16 (27.0)	3/4 (19.1)	2 3/4 (69.9)	3/4 (19.1)	2 3/4 (69.9)	3/4 (19.1)
2241 to 6000 (1017 to 2722)	2 to 8	1 1/2 (38.1)	1 1/16 (27.0)	...	1 1/16 (27.0)	2 3/4 (69.9)	1 1/16 (27.0)	2 3/4 (69.9)	3/4 (19.1)

^A Ends of boxes having a weight content exceeding 2000 lbs (907 kg) or ends of boxes exceeding 12 in. (305 mm) in depth shall be two-ply laminates of equal thickness with the grain reversed.

^B Styles 2, 4, 7, and 8 boxes shall not be required if the depth of the box is 10 in. (254 mm) or less.

^C Nails used for end cleats shall pass through the ends and be clinched to not less than 1/8 in. (3.175 mm). Nailing and clinching of battens shall be in such a manner as to prevent damage by protruding heads or points to the contents of the box.

^D Combined thickness of two-ply end; grain of separate piles reversed.

Class 1 for Level B packing. Unless otherwise specified (see 6.1), the gross weight shall not exceed the weight limitations of the box specification.

7.6.1.9 *Closure and Strapping*—Closure and strapping requirements for wood cleated-plywood boxes and wood, cleated, veneer, paper-overlaid boxes shall be in accordance with the appendix to the applicable box specification (D6251/D6251M, PPP-B-585, or PPP-B-601 as required). (See Table 5.)

7.6.2 Category 2, Drums:

7.6.2.1 *Fiber Drums*—Fiber drums shall be in accordance with Specification PPP-D-723 Type II, Grade A for Level A packing and Type I, Grade A (class optional) for Level B packing.

7.6.2.2 *Metal Drums*—Metal drums shall be in accordance with Specification PPP-D-705 or PPP-D-729 at the option of the contractor.

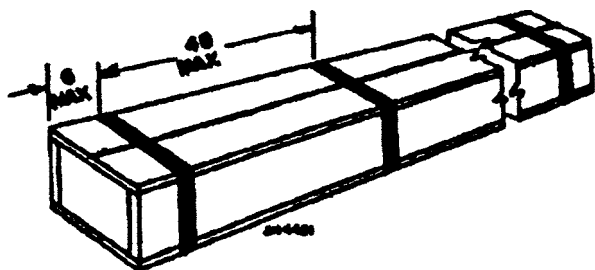

NOTE 1—All dimensions are in inches.

FIG. 1 Style 1 Box

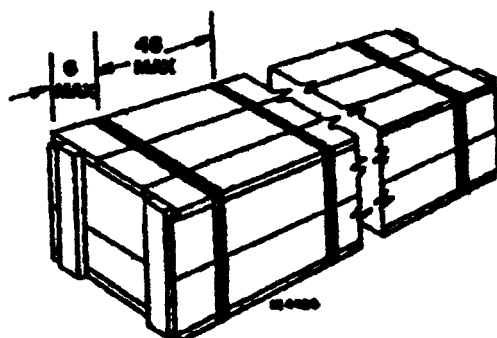

NOTE 1—All dimensions are in inches.

FIG. 4 Style 4 Box

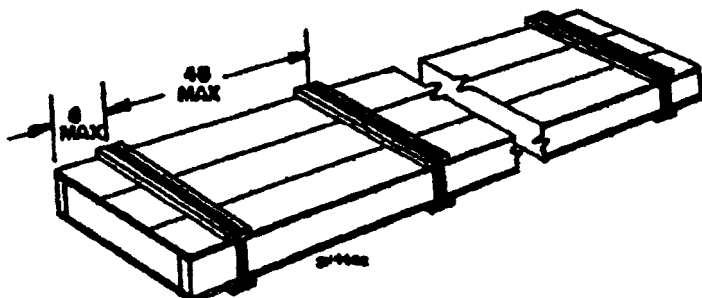

NOTE 1—All dimensions are in inches.

FIG. 2 Style 1A Box (Batten Reinforced Top and Bottom)

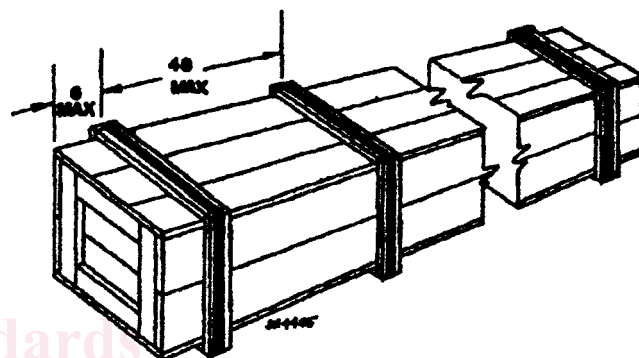

NOTE 1—All dimensions are in inches.

FIG. 5 Style 7 Box (Batten Reinforced)

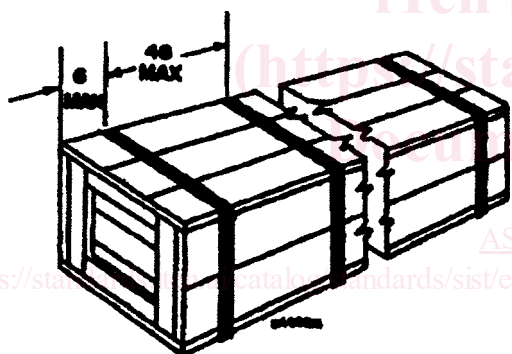

NOTE 1—All dimensions are in inches.

FIG. 3 Style 2 Box

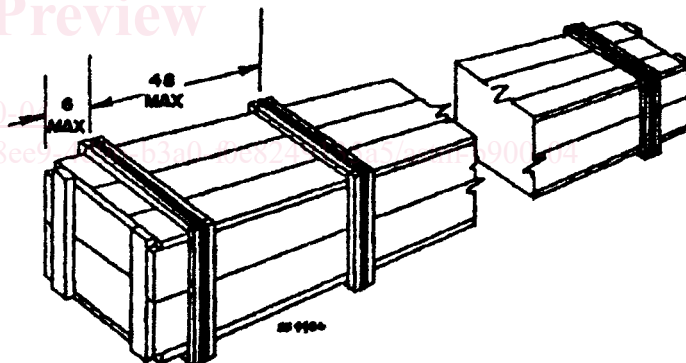

NOTE 1—All dimensions are in inches.

FIG. 6 Style 8 Box (Batten Reinforced)

7.6.3 Category 3 Pallets and Pallet Boxes—Unless otherwise specified (see 8.1), the gross weight shall not exceed 6000 lbs (2722 kg).

7.6.3.1 Pallets—Pallets for Level A or B shipments shall be the expendable type and constructed as follows:

(1) Lumber—All groups of wood (see 7.5.1). Surfaced deck boards of fairly uniform width and spacing.

(2) Thickness:

Deckboards—Groups I and II woods, 1 in. (25.4 mm) minimum. Groups III and IV woods ¾ in. (19.1 mm) minimum.

Stringers—All wood groups, 1½ by 3½ in. (38.1 by 88.9 mm).

(3) Moisture Content:

Deck boards, 22 % maximum.

Stringers, 26 % maximum.

(4) Design:

Types—Single-face, wing-type, two-way entry (see Fig. 7).

Single-face, flush stringer, two-way entry (see Fig. 8).

Single-face, post-construction, four-way entry (see Fig. 9).

Stringers—Three stringers on pallet widths 30 in. (762 mm) and over.

7.6.3.2 Pallet Boxes—Wire-bound or nailed wood boxes with a pallet or skid-type base shall be used (see Figs. 10 and 11). Wire-bound pallet boxes shall be Type I, Class 1 or 2, or Type III, Class 3 or 4 of PPP-B-587, depending on the need for two-way or four-way entry bases and on the weight of contents to be packed. Nailed-wood pallet boxes shall be constructed of ¾-in. (19.1-mm) minimum thickness of material; Group I, II,

TABLE 4 Nails

For Nailing Side to End		For Nailing Top and Bottom to Sides and Ends				
Thickness of Side, in. (mm)	Nail, Minimum	Inside Depth of Side or End, in. (mm)	Thickness of Top and Bottom, in. (mm)			
			1/2 (12.7)	5/8 (15.8)	3/4 (19.1)	1 1/16 (27.0)
5/8 (15.8)	6d	up to 3/4 (19.1), incl	2d	3d	3d	4d
1 1/16 (27.0)	12d	over 3/4 to 1 1/2 (19.2 to 38.1), incl	3d	3d	4d	5d
1 1/2 (38.1)	16d	over 1 1/2 to 3 (38.2 to 76.2), incl	4d	4d	5d	7d
		Over 3 (76.3)	5d	6d	7d	10d

TABLE 5 Minimum Strap Sizes

Weight of Box Contents, lbs (kg)	Width by Thickness Size Strap, in. (mm)
Up to 280 (127)	1/2 by 0.020 (12.7 by 0.51)
281 to 560 (128 to 254)	5/8 by 0.020 (15.8 by 0.51)
561 to 1120 (255 to 508)	3/4 by 0.023 (19.1 by 0.58)
1121 to 2240 (509 to 1016)	3/4 by 0.023 (19.1 by 0.58)
2241 to 6000 (1017 to 2722)	3/4 by 0.035 (19.1 by 0.89)

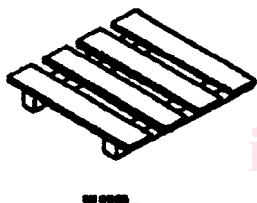

NOTE 1—All dimensions are in inches.
FIG. 7 Single Face Wing Type

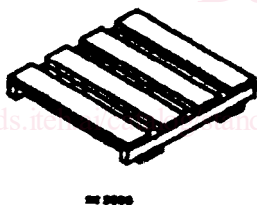

NOTE 1—All dimensions are in inches.
FIG. 8 Single Face (with Bottom Cleats)

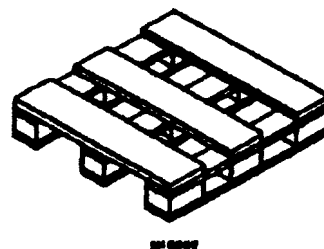

NOTE 1—All dimensions are in inches.
FIG. 9 Four-Way Entry TYPICAL PALLET CONSTRUCTION

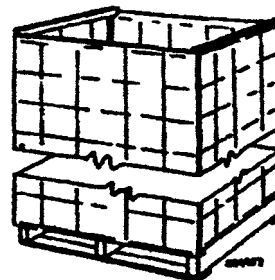

NOTE 1—All dimensions are in inches.
FIG. 10 Pallet Box (Wire-Bound Construction)

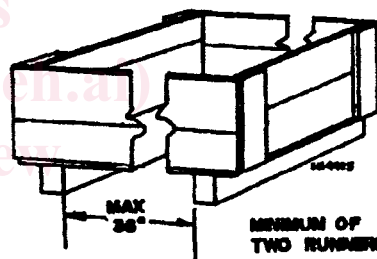

NOTE 1—All dimensions are in inches.
FIG. 11 Pallet Box (Nailed Wood Construction)

III, or IV woods. Stringers shall be minimum 3 1/2 by 3 1/2 in. (88.9 by 88.9 mm) as shown on Fig. 11. If the width of the box exceeds 40 in. (1016 mm), a third stringer shall be added.

7.6.4 Category 4, Skidded Lifts—A skidded lift is a means of packing heavy products by securing skids (runners) to the product itself, either crosswise or lengthwise, with flat steel straps or equivalent strength round wire. Unless otherwise specified (see 6.1), the gross weight of 6000 lbs (2722 kg) is permissible for skidded lifts.

7.6.4.1 Skids (Runners)—Skids shall be sound lumber of not less than 3-in. (76.2-mm) nominal width by 4-in. (101.6-mm) nominal height. Skid ends shall be beveled. The length of the skids shall be the full dimension of the unit along the direction in which they are used. At least two skids shall be used.

7.6.4.2 Strapping—Flat-steel straps or equivalent strength round-wires shall be stapled to the skid ends. Flat steel straps

shall be a minimum of 3/4 by 0.025 in. (19.1 by 0.635 mm). Straps shall not be in direct contact with the product.

7.6.4.3 Protectors—Metal protectors, cushioning packs, or sheets of corrugated fiberboard shall be used between the straps and the product.

7.6.5 Category 5, Hand Bundles—Hand bundles of straight- or flat-length products shall be tied with rope, wire, flat steel straps, or tape in accordance with Specification D5330/D5330M. At least two ties shall be used. Spacing between ties shall not exceed 6 ft (1.83 m). The ties shall be approximately 12 in. (304.8 mm) from each end except where short lengths of the products will not permit. The weight of hand bundles shall not exceed 200 lbs (91 kg).

7.6.5.1 Hand bundles of coiled wire and similar products shall have at least three ties.

7.6.6 Category 6, Secured Lifts Without Skids (Master Bundles)—Secured lifts shall be strapped in accordance with Table 6.

7.6.6.1 Protectors—Metal protectors, fibrous pads, or corrugated fiberboard shall be used under ties of sheet, plate, and