



SLOVENSKI STANDARD

SIST EN 16291-2:2013

01-maj-2013

Steklena embalaža - Grla z navojem za steklenice pod tlakom - 2. del: Nevračljiva steklenica z grlom MCA 2

Glass packaging - Screw finishes for pressure capsules - Part 2: One way glass MCA 2 finish

Verpackungen aus Glas - Schraubmundstücke für Flaschen mit Innendruck - Teil 2: Einweg-MCA 2-Mundstück

Emballage en verre - Bague à vis pour capsules à pression - Partie 2: Bague MCA 2 pour verre perdu

[SIST EN 16291-2:2013](https://standards.iteh.ai/catalog/standards/sist/628afcc7-2e56-485e-aacc-ec08b6720eb6/sist-en-16291-2-2013)

[https://standards.iteh.ai/catalog/standards/sist/628afcc7-2e56-485e-aacc-](https://standards.iteh.ai/catalog/standards/sist/628afcc7-2e56-485e-aacc-ec08b6720eb6/sist-en-16291-2-2013)

[ec08b6720eb6/sist-en-16291-2-2013](https://standards.iteh.ai/catalog/standards/sist/628afcc7-2e56-485e-aacc-ec08b6720eb6/sist-en-16291-2-2013)

Ta slovenski standard je istoveten z: EN 16291-2:2013

ICS:

55.100 Steklenice. Lonci. Kozarci Bottles. Pots. Jars

SIST EN 16291-2:2013

en,fr,de

iTeh STANDARD PREVIEW
(standards.iteh.ai)

[SIST EN 16291-2:2013](https://standards.iteh.ai/catalog/standards/sist/628afcc7-2e56-485e-aacc-ec08b6720eb6/sist-en-16291-2-2013)

<https://standards.iteh.ai/catalog/standards/sist/628afcc7-2e56-485e-aacc-ec08b6720eb6/sist-en-16291-2-2013>

EUROPEAN STANDARD
NORME EUROPÉENNE
EUROPÄISCHE NORM

EN 16291-2

March 2013

ICS 55.100

English Version

Glass packaging - Screw finishes for pressure capsules - Part 2: One way glass MCA 2 finish

Emballage en verre - Bagues à vis pour capsules à
pression - Partie 2: Bague MCA 2 pour verre perdu

Verpackungen aus Glas - Schraubmundstücke für
Flaschen mit Innendruck - Teil 2: Einweg-MCA 2-
Mundstück

This European Standard was approved by CEN on 12 January 2013.

CEN members are bound to comply with the CEN/CENELEC Internal Regulations which stipulate the conditions for giving this European Standard the status of a national standard without any alteration. Up-to-date lists and bibliographical references concerning such national standards may be obtained on application to the CEN-CENELEC Management Centre or to any CEN member.

This European Standard exists in three official versions (English, French, German). A version in any other language made by translation under the responsibility of a CEN member into its own language and notified to the CEN-CENELEC Management Centre has the same status as the official versions.

CEN members are the national standards bodies of Austria, Belgium, Bulgaria, Croatia, Cyprus, Czech Republic, Denmark, Estonia, Finland, Former Yugoslav Republic of Macedonia, France, Germany, Greece, Hungary, Iceland, Ireland, Italy, Latvia, Lithuania, Luxembourg, Malta, Netherlands, Norway, Poland, Portugal, Romania, Slovakia, Slovenia, Spain, Sweden, Switzerland, Turkey and United Kingdom.

<https://standards.iteh.ai/catalog/standards/sist/628afcc7-2e56-485e-aacc-ec08b6720eb6/sist-en-16291-2-2013>



EUROPEAN COMMITTEE FOR STANDARDIZATION
COMITÉ EUROPÉEN DE NORMALISATION
EUROPÄISCHES KOMITEE FÜR NORMUNG

Management Centre: Avenue Marnix 17, B-1000 Brussels

Contents	Page
Foreword.....	3
Introduction	4
1 Scope	5
2 Terms and definitions	5
3 Dimensions	5
Bibliography	10

iTeh STANDARD PREVIEW
(standards.iteh.ai)

[SIST EN 16291-2:2013](https://standards.iteh.ai/catalog/standards/sist/628afcc7-2e56-485e-aacc-ec08b6720eb6/sist-en-16291-2-2013)

<https://standards.iteh.ai/catalog/standards/sist/628afcc7-2e56-485e-aacc-ec08b6720eb6/sist-en-16291-2-2013>

Foreword

This document (EN 16291-2:2013) has been prepared by Technical Committee CEN/TC 261 “Packaging”, the secretariat of which is held by AFNOR.

This European Standard shall be given the status of a national standard, either by publication of an identical text or by endorsement, at the latest by September 2013, and conflicting national standards shall be withdrawn at the latest by September 2013.

Attention is drawn to the possibility that some of the elements of this document may be the subject of patent rights. CEN [and/or CENELEC] shall not be held responsible for identifying any or all such patent rights.

EN 16291, *Glass packaging — Screw finishes for pressure capsules*, consists of the following parts:

- *Part 1: Returnable glass MCA 2 finish;*
- *Part 2: One way glass MCA 2 finish.*

According to the CEN/CENELEC Internal Regulations, the national standards organisations of the following countries are bound to implement this European Standard: Austria, Belgium, Bulgaria, Croatia, Cyprus, Czech Republic, Denmark, Estonia, Finland, Former Yugoslav Republic of Macedonia, France, Germany, Greece, Hungary, Iceland, Ireland, Italy, Latvia, Lithuania, Luxembourg, Malta, Netherlands, Norway, Poland, Portugal, Romania, Slovakia, Slovenia, Spain, Sweden, Switzerland, Turkey and the United Kingdom.

SIST EN 16291-2:2013

<https://standards.iteh.ai/catalog/standards/sist/628afcc7-2e56-485e-aacc-ec08b6720eb6/sist-en-16291-2-2013>

Introduction

This document is based on CE.T.I.E. (International Technical Centre for Bottling and related Packaging) data sheet GME 320 [1].

Efficient packaging is of great importance for the distribution and the protection of goods. Insufficient or inappropriate packaging can lead to damage or wastage of the contents of the pack.

iTeh STANDARD PREVIEW (standards.iteh.ai)

SIST EN 16291-2:2013

<https://standards.iteh.ai/catalog/standards/sist/628afcc7-2e56-485e-aacc-ec08b6720eb6/sist-en-16291-2-2013>

1 Scope

This European Standard specifies the dimensions of the screw finish for glass containers designated MCA 2 for one way glass.

2 Terms and definitions

For the purposes of this document, the following term and definition applies.

2.1

MCA

(glass) finish designed for the closure of pressurised or vacuum liquids with a tamper-evident closure (metal or plastic)

3 Dimensions

The design and dimensions of the finish shall be as shown in Table 1 and Figures 1, 2, 3, 4 and 5.

Table 1 – Design and dimensions of the finish

Pitch	β	TPI	\varnothing cutter
3,175 mm	2° 12'	8	12,5 mm
<p>β = Helix angle or angle of fixture to cutter</p> <p>NOTE TPI = threads per inch. One inch is equal to 25,4 mm.</p>			

The $\tan \beta$ of helix angle for cutter is calculated via the following formula:

$$\tan \beta = \frac{\text{pitch}}{\pi(\text{nominal T} + \text{nominal E})}$$

where

T is the thread diameter;

E is the wall diameter of threaded finish.

The average of the maximum and minimum of "L" diameter is as close as possible to "L" nominal.

The mean diameter $L = \frac{\text{diameter max} + \text{diameter min}}{2}$ is in the tolerance of $\pm 0,2$ mm.

Optional: depressed thread at mould parting line (see EN 16292).

Dimensions in millimetres

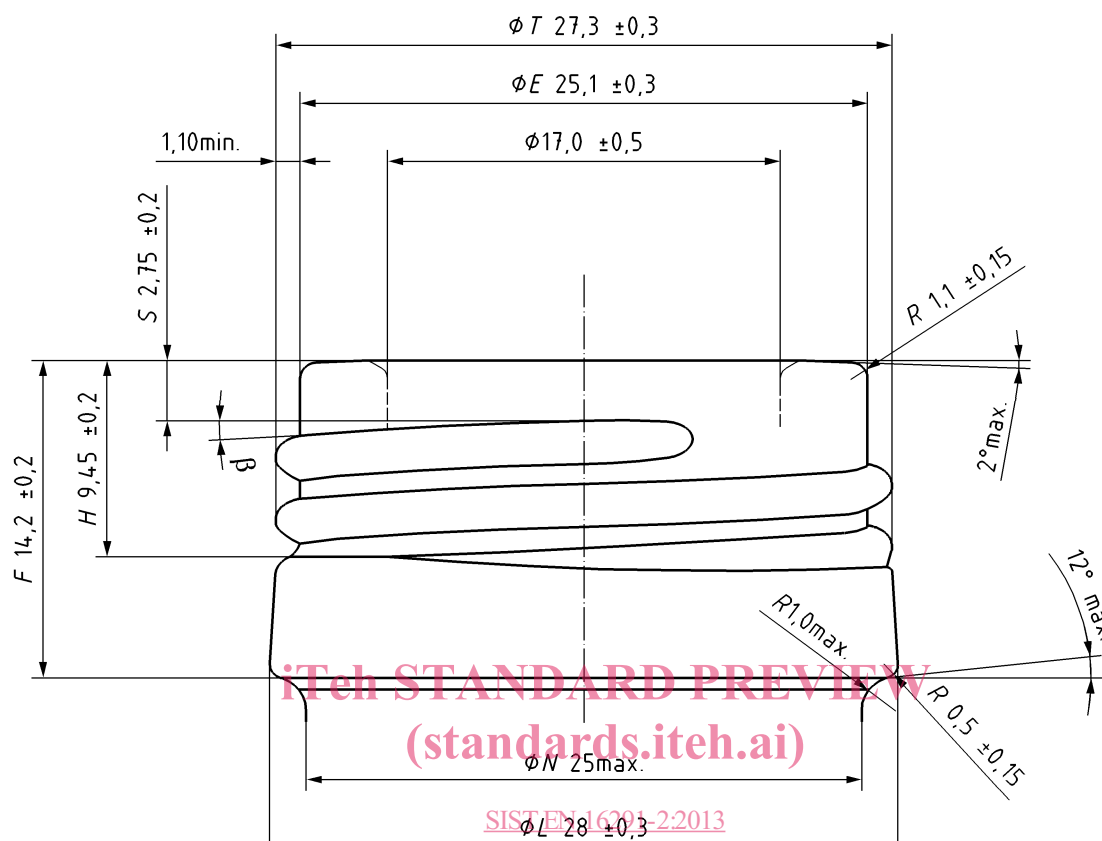

SIST EN 16291-2:2013
<https://standards.iteh.ai/catalog/standards/sist/628afcc7-2e56-485c-aacc-ec08b6720eb6/sist-en-16291-2-2013>

Key

- N neck (under bead) diameter
- H thread height
- S start of thread position from sealing surface to intersection of thread flank
- F height of the finish
- L locking bead diameter
- T thread diameter
- E wall diameter of threaded finish

NOTE Bore diameter: $18,1 \text{ mm} \pm 1,0 \text{ mm}$ for a depth of 3mm.

Figure 1 – MCA 2 finish

Dimensions in millimetres

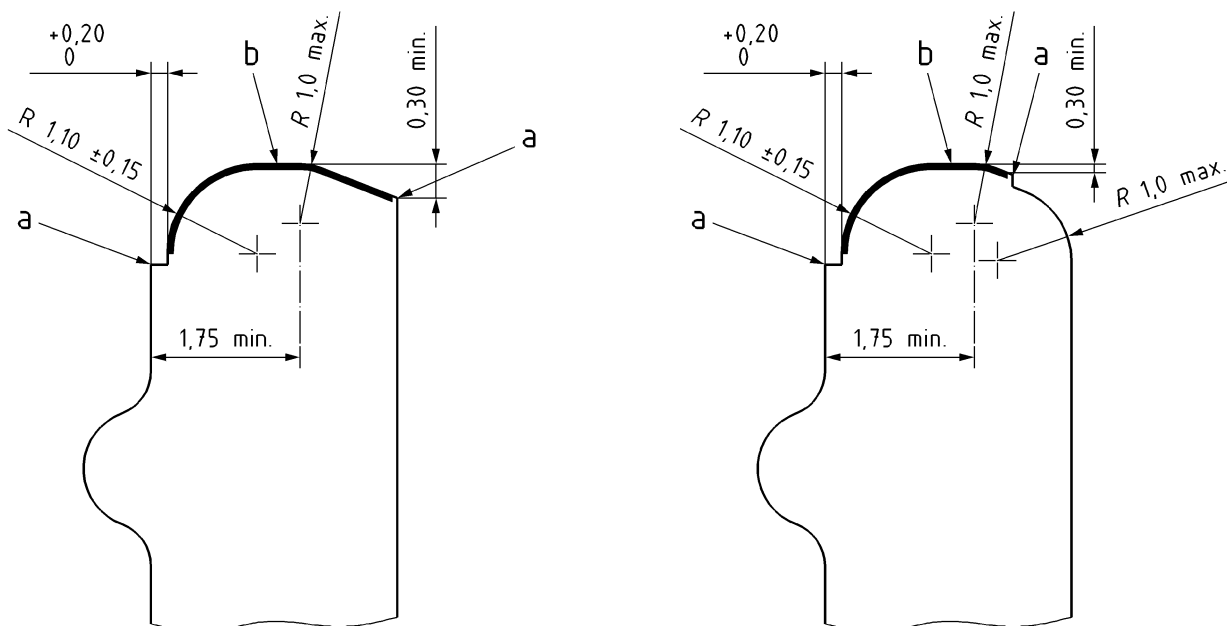
**Key**

- a mould parting line
- b sealing surface

iTeh STANDARD PREVIEW
(standards.iteh.ai)

The sealing surface is smooth and free of any defects and flash.

<https://standards.iteh.ai/catalog/standards/sist/628afcc7-2e56-485e-aacc-ec08b6720eb6/sist-en-16291-2-2013>

Figure 2 — Possible alternative constructions of the bore entrance to suit glass manufacturer