**Castors and wheels — Requirements for
applications over 1,1 m/s (4 km/h) and up
to 4,4 m/s (16 km/h)**

*Roues et roulettes — Exigences pour des applications à plus de 1,1 m/s
(4 km/h) et jusqu'à 4,4 m/s (16 km/h)*

iTeh STANDARD PREVIEW
(standards.iteh.ai)

[ISO 22884:2004](https://standards.iteh.ai/catalog/standards/sist/2b15867b-6ce5-4e31-aa68-7148294dc0ef/iso-22884-2004)

[https://standards.iteh.ai/catalog/standards/sist/2b15867b-6ce5-4e31-aa68-
7148294dc0ef/iso-22884-2004](https://standards.iteh.ai/catalog/standards/sist/2b15867b-6ce5-4e31-aa68-7148294dc0ef/iso-22884-2004)



PDF disclaimer

This PDF file may contain embedded typefaces. In accordance with Adobe's licensing policy, this file may be printed or viewed but shall not be edited unless the typefaces which are embedded are licensed to and installed on the computer performing the editing. In downloading this file, parties accept therein the responsibility of not infringing Adobe's licensing policy. The ISO Central Secretariat accepts no liability in this area.

Adobe is a trademark of Adobe Systems Incorporated.

Details of the software products used to create this PDF file can be found in the General Info relative to the file; the PDF-creation parameters were optimized for printing. Every care has been taken to ensure that the file is suitable for use by ISO member bodies. In the unlikely event that a problem relating to it is found, please inform the Central Secretariat at the address given below.

iTeh STANDARD PREVIEW
(standards.iteh.ai)

ISO 22884:2004

<https://standards.iteh.ai/catalog/standards/sist/2b15867b-6ce5-4e31-aa68-7148294dc0ef/iso-22884-2004>

© ISO 2004

All rights reserved. Unless otherwise specified, no part of this publication may be reproduced or utilized in any form or by any means, electronic or mechanical, including photocopying and microfilm, without permission in writing from either ISO at the address below or ISO's member body in the country of the requester.

ISO copyright office
Case postale 56 • CH-1211 Geneva 20
Tel. + 41 22 749 01 11
Fax + 41 22 749 09 47
E-mail copyright@iso.org
Web www.iso.org

Published in Switzerland

Contents

	Page
1 Scope	1
2 Normative references	1
3 Terms and definitions	1
4 Classification, characteristics and dimensions	1
4.1 Classification	1
4.2 Characteristics	1
4.3 Top plate	2
4.4 Offset	3
4.5 Wheel	3
4.6 Load capacity	6
5 Requirements for testing	6
5.1 General	6
5.2 Standard conditions	6
5.3 Initial wheel play	7
5.4 Initial swivel play	7
5.5 Electrical resistance test	8
5.6 Fatigue test for braking and/or locking device	8
5.7 Efficiency check of wheel braking and/or locking device	9
5.8 Efficiency check of swivel braking and/or locking device	10
5.9 Static test	10
5.10 Dynamic test	10
5.11 Efficiency check of wheel braking and/or locking device	12
5.12 Efficiency check of swivel braking and/or locking device	12
5.13 Final wheel play	12
5.14 Final swivel play	12
6 Conformity	12
7 Marking of the product	13
7.1 Product marking	13
7.2 Marking of electrically conductive or antistatic castors or wheels	13
Bibliography	14

Foreword

ISO (the International Organization for Standardization) is a worldwide federation of national standards bodies (ISO member bodies). The work of preparing International Standards is normally carried out through ISO technical committees. Each member body interested in a subject for which a technical committee has been established has the right to be represented on that committee. International organizations, governmental and non-governmental, in liaison with ISO, also take part in the work. ISO collaborates closely with the International Electrotechnical Commission (IEC) on all matters of electrotechnical standardization.

International Standards are drafted in accordance with the rules given in the ISO/IEC Directives, Part 2.

The main task of technical committees is to prepare International Standards. Draft International Standards adopted by the technical committees are circulated to the member bodies for voting. Publication as an International Standard requires approval by at least 75 % of the member bodies casting a vote.

Attention is drawn to the possibility that some of the elements of this document may be the subject of patent rights. ISO shall not be held responsible for identifying any or all such patent rights.

ISO 22884 was prepared by Technical Committee ISO/TC 110, *Industrial trucks*, Subcommittee SC 3, *Castors and wheels*.

This first edition of ISO 22884 cancels and replaces ISO 2175:1981, ISO 2184-1:1972, ISO 3101:1981 and ISO 3102:1981.

iTeh STANDARD PREVIEW
(standards.iteh.ai)
ISO 22884:2004
<https://standards.iteh.ai/catalog/standards/sist/2b15867b-6ce5-4e31-aa68-7148294dc0ef/iso-22884-2004>

Castors and wheels — Requirements for applications over 1,1 m/s (4 km/h) and up to 4,4 m/s (16 km/h)

1 Scope

This International Standard specifies the technical requirements, the appropriate dimensions and the requirements for testing of castors and wheels (which may include accessories), specifically for manually propelled or power-towed industrial applications at speeds over 1,1 m/s (4 km/h) and up to 4,4 m/s (16 km/h).

Pneumatic wheels and drive wheels are not covered by this International Standard.

2 Normative references

The following referenced documents are indispensable for the application of this document. For dated references, only the edition cited applies. For undated references, the latest edition of the referenced document (including any amendments) applies.

ISO 22877, *Castors and wheels — Vocabulary, symbols and multilingual terminology*

ISO 22878:2004, *Castors and wheels — Test methods and apparatus*

3 Terms and definitions

For the purposes of this document, the terms and definitions given in ISO 22877 apply. Symbols are given in ISO 22878:2004, Annex A.

4 Classification, characteristics and dimensions

4.1 Classification

The castors and wheels are divided into three categories: A, B and C. These categories define three increasing speed ratings and are listed in Table 1.

Table 1

Category	A	B	C
Speed, m/s (km/h)	1,7 (6)	2,8 (10)	4,4 (16)

4.2 Characteristics

The characteristics of a castor are

- top plate,
- offset,
- wheel, and
- load capacity.

4.3 Top plate

Rectangular top plates are used with four fixing holes. The design of the outer profile is left to the manufacturer, provided that it is inscribed in a rectangle of maximum size $l \times b$ as indicated in Table 2 and shown in Figure 1.

The fixing holes are located at the corners of a rectangle inscribed in the outer profile. The holes may be oblong and form slots, provided the width of the slot is suitable for bolts of diameter (D_{G1}) as in Table 2.

Table 2 lists the standardized dimensions of the different classes of top plates.

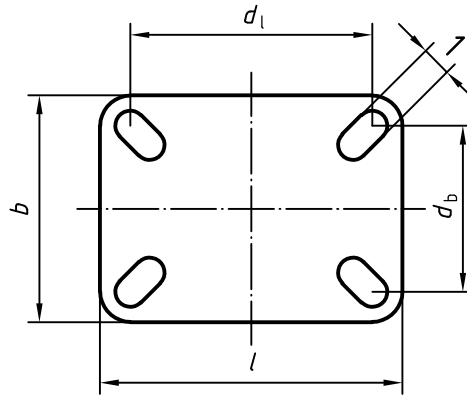

Key

1 adapted to D_{G1}

iTeh STANDARD PREVIEW
(standards.iteh.ai)

NOTE The symbols $A \times B$ (top plate outer dimensions) and $a \times b$ (bolt hole spacing) may be used in place of the recommended symbols stated above as these are of common use within the trade.

ISO 22884:2004
<https://standards.iteh.ai/catalog/standards/iso/22884-2004/iso-22884-2004-7148294dc0ef>

Figure 1 — Rectangular top plate

Table 2

Dimensions in millimetres

Class	Top plate outer dimensions $l \times b$	Bolt hole spacing $d_l \times d_b$	Fixing bolt diameter D_{G1}
R51	160 × 120	105 × 80	10
			12
R52	180 × 160	140 × 105	10
			12
			14
			16
R53	230 × 180	160 × 120	12
			14
			16
			20
R54	270 × 230	210 × 160	14
			16
			20

4.4 Offset

Table 3 specifies the minimum and maximum offset values (d_F) for swivel castors, corresponding to the wheel diameter (D), as in Figure 2.

For shock-absorbing castors, the offset may vary from the dimensions stated.

Table 3

Dimensions in millimetres

Wheel diameter D	Offset d_F	
	Minimum	Maximum
125	25	75
150/160	30	95
200	40	120
250	50	150
280/300	55	180
350/360	70	215
400	80	240
450	90	270
500	100	300

iTeh STANDARD PREVIEW
(standards.iteh.ai)

ISO 22884:2004
<https://standards.iteh.ai/catalog/standards/sist/2b15867b-6ce5-4e31-aa68-7148294dc0ef/iso-22884-2004>

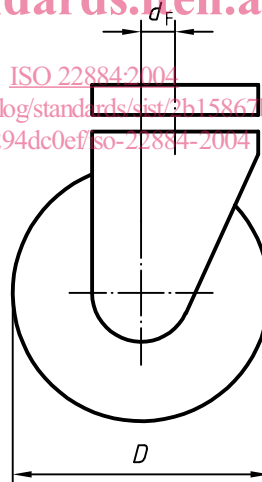

Figure 2 — Offset

4.5 Wheel

4.5.1 Characteristics

The characteristics of a wheel are

- diameter,
- hub width,
- bore diameter, and
- load capacity.

The characteristics of the wheel are illustrated in Figure 3 and the hub width (b_{T1}) and bore diameter (D_d) corresponding to each wheel diameter (D) are listed in Table 4. Wheels are not restricted to these hub widths and bores when used in castors.

The user shall verify the mechanical strength of axle components (bolts, nuts, bushes, spacers, etc.).

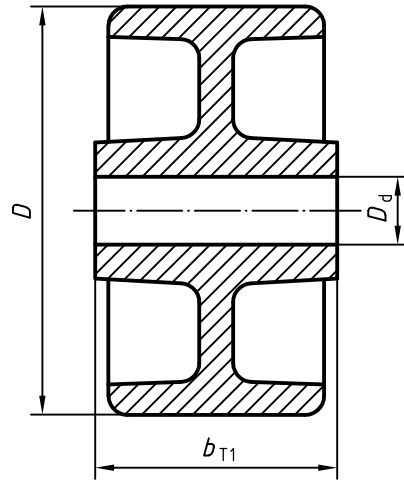

Figure 3 — Wheel dimensions
 iTeh STANDARD PREVIEW
 (standards.iteh.ai)

Dimensions in millimetres

Wheel diameter D	Hub width b_{T1}	Bore diameters ^a D_d
125	50	20
		25
150/160	60	20
		25
200	60	20
		25
	75	25
		30
250	60	25
		30
	75	25
		30
	90	25
30		
140	30	
	40	

Table 4 (continued)

Dimensions in millimetres

Wheel diameter D	Hub width b_{T1}	Bore diameters ^a D_d
280	60	25
		30
	75	25
300	90	30
		35
	120	40
350/360	75	35
		40
	90	40
400	75	40
		45
	90	50
		55
	120	60
		65
450	90	70
		75
	120	80
500	90	80
		85
	120	90
500	160	90
		95

^a The above bores refer to the nominal diameter of the axle.

4.5.2 Wheel diameter tolerance

The tolerance on wheel diameter (D) shall be $\pm 1,5\%$.

4.5.3 Hub width tolerance

The tolerance on hub width (b_{T1}) shall be $\begin{matrix} 0 \\ -2\% \end{matrix}$.

4.6 Load capacity

This is the maximum load, in newtons, which can be carried by a wheel or a castor so as to fully comply with the required acceptance criteria.

5 Requirements for testing

5.1 General

Test apparatus and procedures shall be as specified in ?ISO 22878:~?. A static test is not required for this type of castor.

5.2 Standard conditions

5.2.1 Environmental conditions

Tests shall be carried out at a temperature between 15 °C and 28 °C. During the 24 h prior to the test, the samples shall remain at the specified temperature, in an environment with a relative humidity between 40 % and 70 %.

Samples shall not be artificially cooled during testing.

iTeh STANDARD PREVIEW
(standards.iteh.ai)

5.2.2 Test sequence

Tests, where applicable, shall be carried out in the sequence as listed in Table 5.

ISO 22884:2004
Table 5
<https://standards.iteh.ai/catalog/standards/sist/2b15867b-6ce5-4e31-aa68-7148294dc0ef/iso-22884-2004>

Reference in this International Standard	Test sequence	Castors and wheel types	Test procedures given in ISO 22878:2004, subclause
5.3	Initial wheel play	All castors	4.2
5.4	Initial swivel play	Swivel castors with or without accessories	4.3
5.5	Electrical resistance	Castors and wheels electrically conductive or antistatic	4.4
5.6	Fatigue test for braking and/or locking device	Castors with — wheel locking/braking device — directional locking device — total locking/braking device — central locking/braking device If device is operated by means of threaded mechanism this test will not be applicable.	4.5
5.7	Efficiency check of wheel braking and/or locking device	Castors with — wheel locking/braking device — total locking/braking device — central locking/braking device	4.6
5.8	Efficiency check of swivel braking and/or locking device	Castors with — directional locking/braking device — total locking/braking device — central locking/braking device	4.7

Table 5 (continued)

Reference in this International Standard	Test sequence	Castors and wheel types	Test procedures given in ISO 22878:2004, subclause
5.9	Static test	This test is not required	4.9
5.10	Dynamic test	All castors	4.8
5.11	Efficiency check of wheel braking and/or locking device	Castors with — wheel locking/braking device — total locking/braking device — central locking/braking device	4.6
5.12	Efficiency check of swivel braking and/or locking device	Castors with — directional locking/braking device — total locking/braking device — central locking/braking device	4.7
5.13	Final wheel play	All castors	4.2
5.14	Final swivel play	Swivel castors with or without accessories	4.3

5.3 Initial wheel play

iTech STANDARD PREVIEW
(standards.iteh.ai)

5.3.1 Test objectives, apparatus and procedures

These shall be as specified in ISO 22878:2004, 4.2.

[ISO 22884:2004](https://standards.iteh.ai/catalog/standards/sist/2b15867b-6ce5-4e31-aa68-7148294dc0ef/iso-22884-2004)

<https://standards.iteh.ai/catalog/standards/sist/2b15867b-6ce5-4e31-aa68-7148294dc0ef/iso-22884-2004>

5.3.2 Acceptance criteria

[7148294dc0ef/iso-22884-2004](https://standards.iteh.ai/catalog/standards/sist/2b15867b-6ce5-4e31-aa68-7148294dc0ef/iso-22884-2004)

The measured initial wheel play shall not exceed the value d_{W1} given in Table 6.

Table 6

Symbol	Value	Description
D	variable	wheel diameter
d_{W1}	0,5 % of D	maximum initial wheel play

5.4 Initial swivel play

5.4.1 Test objectives, apparatus and procedures

These shall be as specified in ISO 22878:2004, 4.3.

5.4.2 Acceptance criteria

The measured initial swivel play shall not exceed the value d_{S1} given in Table 7.

Table 7

Symbol	Value	Description
d_{S1}	3 mm	maximum initial swivel play