**Bonded abrasive products — Permissible
unbalances of grinding wheels as
delivered — Static testing**

*Produits abrasifs agglomérés — Balourds admissibles des meules en
état de livraison — Contrôle statique*

iTeh STANDARD PREVIEW
(standards.iteh.ai)

[ISO 6103:2005](https://standards.iteh.ai/catalog/standards/sist/64133631-a547-45b5-92dc-d3c17f78e1e2/iso-6103-2005)

[https://standards.iteh.ai/catalog/standards/sist/64133631-a547-45b5-92dc-
d3c17f78e1e2/iso-6103-2005](https://standards.iteh.ai/catalog/standards/sist/64133631-a547-45b5-92dc-d3c17f78e1e2/iso-6103-2005)



PDF disclaimer

This PDF file may contain embedded typefaces. In accordance with Adobe's licensing policy, this file may be printed or viewed but shall not be edited unless the typefaces which are embedded are licensed to and installed on the computer performing the editing. In downloading this file, parties accept therein the responsibility of not infringing Adobe's licensing policy. The ISO Central Secretariat accepts no liability in this area.

Adobe is a trademark of Adobe Systems Incorporated.

Details of the software products used to create this PDF file can be found in the General Info relative to the file; the PDF-creation parameters were optimized for printing. Every care has been taken to ensure that the file is suitable for use by ISO member bodies. In the unlikely event that a problem relating to it is found, please inform the Central Secretariat at the address given below.

iTeh STANDARD PREVIEW
(standards.iteh.ai)

[ISO 6103:2005](#)

<https://standards.iteh.ai/catalog/standards/sist/64133631-a547-45b5-92dc-d3c17f78e1e2/iso-6103-2005>

© ISO 2005

All rights reserved. Unless otherwise specified, no part of this publication may be reproduced or utilized in any form or by any means, electronic or mechanical, including photocopying and microfilm, without permission in writing from either ISO at the address below or ISO's member body in the country of the requester.

ISO copyright office
Case postale 56 • CH-1211 Geneva 20
Tel. + 41 22 749 01 11
Fax + 41 22 749 09 47
E-mail copyright@iso.org
Web www.iso.org

Published in Switzerland

Foreword

ISO (the International Organization for Standardization) is a worldwide federation of national standards bodies (ISO member bodies). The work of preparing International Standards is normally carried out through ISO technical committees. Each member body interested in a subject for which a technical committee has been established has the right to be represented on that committee. International organizations, governmental and non-governmental, in liaison with ISO, also take part in the work. ISO collaborates closely with the International Electrotechnical Commission (IEC) on all matters of electrotechnical standardization.

International Standards are drafted in accordance with the rules given in the ISO/IEC Directives, Part 2.

The main task of technical committees is to prepare International Standards. Draft International Standards adopted by the technical committees are circulated to the member bodies for voting. Publication as an International Standard requires approval by at least 75 % of the member bodies casting a vote.

Attention is drawn to the possibility that some of the elements of this document may be the subject of patent rights. ISO shall not be held responsible for identifying any or all such patent rights.

ISO 6103 was prepared by Technical Committee ISO/TC 29, *Small tools*, Subcommittee SC 5, *Grinding wheels and abrasives*.

This third edition cancels and replaces the second edition (ISO 6103:1999), which has been technically revised.

iTeh STANDARD PREVIEW
(standards.iteh.ai)

<https://standards.iteh.ai/catalog/standards/sist/64133631-a547-45b5-92dc-d3c17f78e1e2/iso-6103-2005>

iTeh STANDARD PREVIEW
(standards.iteh.ai)

ISO 6103:2005

<https://standards.iteh.ai/catalog/standards/sist/64133631-a547-45b5-92dc-d3c17f78e1e2/iso-6103-2005>

Bonded abrasive products — Permissible unbalances of grinding wheels as delivered — Static testing

1 Scope

This International Standard specifies the maximum permissible values of unbalances for various grinding wheels of ISO 603-1 to ISO 603-9 and ISO 603-12 to ISO 603-16 in the as-delivered condition, with an outside diameter $D > 115$ mm and maximum operating speed $v_s \geq 16$ m/s.

It also specifies the method for measuring the unbalance and the practical method for testing whether a grinding wheel is acceptable or not.

This International Standard is applicable to bonded abrasive grinding wheels in the as-delivered condition.

This International Standard is not applicable to

- diamond, cubic boron nitride or natural stone grinding wheels, or to
- centreless control wheels, lapping and disc wheels, ball wheels or glass grinding wheels.

NOTE 1 The values given refer to the grinding wheel itself, independent of any unbalance which may exist in the balancing arbor or in the means of fastening it to this arbor. These various elements, together with the flanges or hub-flanges, are assumed to be balanced, homogeneous and free from geometrical defects.

NOTE 2 The effects of unbalance are basically

- additional stresses on the arbor, the machine and its mounting,
- excessive wear of the bearings,
- vibration prejudicial to the quality of machining and increased internal stresses in the grinding wheel, and
- increased operator fatigue.

2 Normative references

The following referenced documents are indispensable for the application of this document. For dated references, only the edition cited applies. For undated references, the latest edition of the referenced document (including any amendments) applies.

ISO 603-1, *Bonded abrasive products — Dimensions — Part 1: Grinding wheels for external cylindrical grinding between centres*

ISO 603-2, *Bonded abrasive products — Dimensions — Part 2: Grinding wheels for centreless external cylindrical grinding*

ISO 603-3, *Bonded abrasive products — Dimensions — Part 3: Grinding wheels for internal cylindrical grinding*

ISO 6103:2005(E)

ISO 603-4, *Bonded abrasive products — Dimensions — Part 4: Grinding wheels for surface grinding/peripheral grinding*

ISO 603-5, *Bonded abrasive products — Dimensions — Part 5: Grinding wheels for surface grinding/face grinding*

ISO 603-6, *Bonded abrasive products — Dimensions — Part 6: Grinding wheels for tool and tool room grinding*

ISO 603-7, *Bonded abrasive products — Dimensions — Part 7: Grinding wheels for manually guided grinding*

ISO 603-8, *Bonded abrasive products — Dimensions — Part 8: Grinding wheels for deburring and fettling/snagging*

ISO 603-9, *Bonded abrasive products — Dimensions — Part 9: Grinding wheels for high pressure grinding*

ISO 603-12, *Bonded abrasive products — Dimensions — Part 12: Grinding wheels for deburring and fettling on a straight grinder*

ISO 603-13, *Bonded abrasive products — Dimensions — Part 13: Grinding wheels for deburring and fettling on a vertical grinder*

ISO 603-14, *Bonded abrasive products — Dimensions — Part 14: Grinding wheels for deburring and fettling/snagging on an angle grinder*

ISO 603-15, *Bonded abrasive products — Dimensions — Part 15: Grinding wheels for cutting-off on stationary and mobile cutting-off machines*

ISO 603-16, *Bonded abrasive products — Dimensions — Part 16: Grinding wheels for cutting-off on hand held power tools*

ITeH STANDARD PREVIEW
(standards.iteh.ai)
<https://standards.iteh.ai/catalog/standards/sist/64133631-a547-45b5-92dc-d3c17f78e1e2/iso-6103-2005>

3 Terms and definitions

For the purposes of this document, the following terms and definitions apply.

3.1

unbalance

product of the radius, in millimetres, and mass, in grams, expressed in grams multiplied by millimetres

3.2

intrinsic unbalance of a grinding wheel

U_i
product of the mass m_1 of the grinding wheel and the distance e between its centre of mass G (centre of gravity) and the axis O of its bore

See Figure 1.

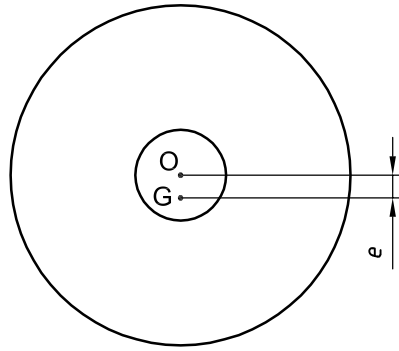

$$U_i = m_1 \cdot e$$

Figure 1

3.3 measured unbalance

 U_c

product of a mass, m_2 , affixed to the grinding wheel to balance it and the distance between the centre of mass (G_{m2}) (centre of gravity) of the mass m_2 and the axis O of the grinding wheel bore

See Figure 2.

NOTE In practice, this distance is equal to the radius r of the grinding wheel.

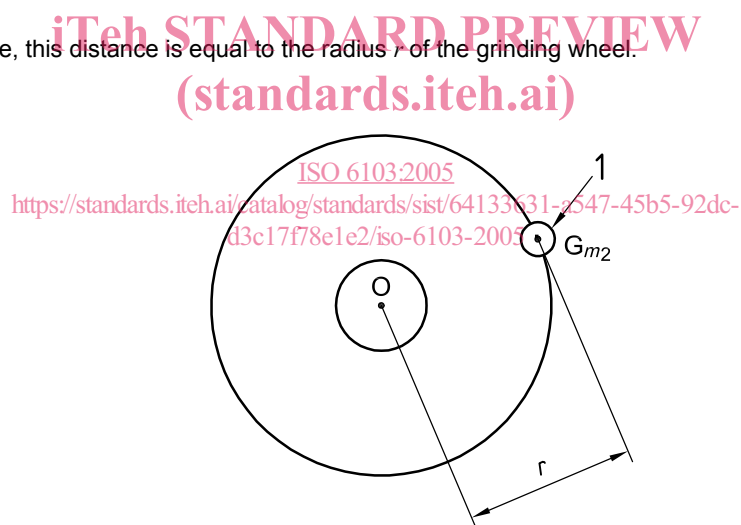

$$U_c = m_2 \cdot r$$

Key

1 mass m_2

Figure 2

4 Permissible unbalance, U_a

On the basis of experience, the maximum permissible unbalance U_a is determined using a mass $m_a = U_a/r$, such that

$$m_a = k\sqrt{m_1} \quad (1)$$

where

- r is the radius of the grinding wheel, in millimetres;
- m_a is the mass whose centre is located on the circumference of the grinding wheel, in grams;
- m_1 is the mass of the grinding wheel, in grams;
- k is a coefficient which depends on the nature and usage of the grinding wheel.

The values of k are given in Table 1 and the values of m_a , as a function of m_1 and k , are shown in Figure 5.

The values of k have been selected on the basis of experience so that the resulting unbalance allows for normal usage of the grinding wheel.

5 Measuring intrinsic unbalance

Place a balancing arbor through the bore of the grinding wheel to hold its mid-plane in a vertical position. For straight wheels or wheels of similar shape, the wheel is free-standing; wheels of other shapes may be supported using suitable flanges.

Rest the balancing arbor on two parallel horizontal bevelled guide-bars or cylindrical bars (see Figure 3), or on a balancing stand consisting of two pairs of overlapping, freely rotating, steel discs (see Figure 4), so that the grinding wheel attains an equilibrium position with minimum friction.

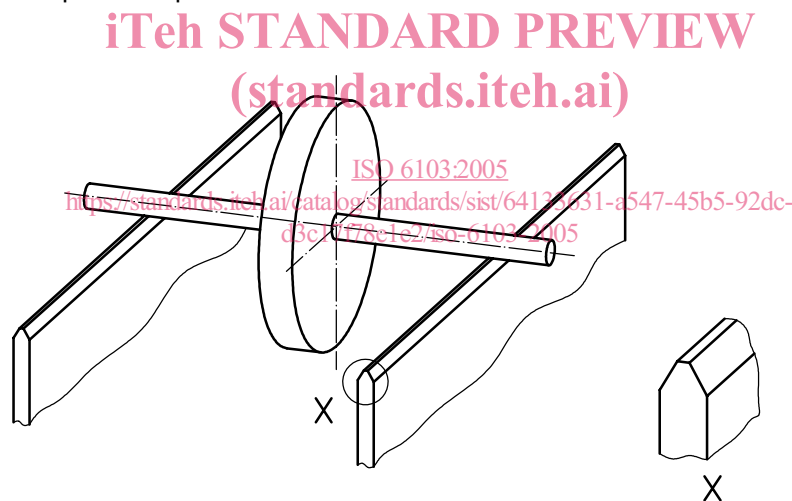

Alternative: the two bevelled guide-bars may be replaced by two cylindrical bars.

Figure 3

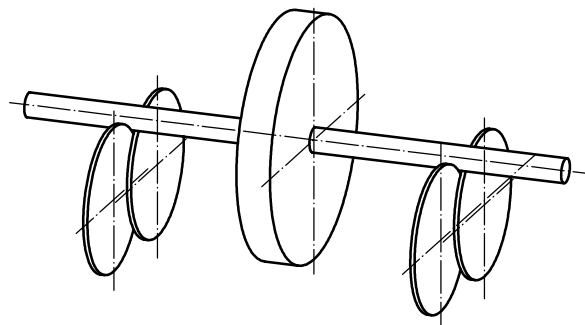

Figure 4

The clearance between the balancing arbor and the bore of the grinding wheel shall not exceed 0,4 mm.

The arbor and the supports (guide-bars, bars or discs) shall have an adequate surface hardness and an appropriate surface condition to minimize friction.

When the grinding wheel attains the equilibrium position, its centre of mass is then as low as possible. In this position, mark the upper peripheral point of the grinding wheel.

Rotate the grinding wheel through 90° to bring this mark into the horizontal plane for the arbor axis.

Determine the mass m_2 which, when affixed to the periphery of the grinding wheel at the mark, maintains the grinding wheel in equilibrium. The amount of unbalance thus introduced, $U_c = m_2 \cdot r$, is equal and opposite to the intrinsic unbalance of the wheel.

The value of the mass m_2 is used to determine the intrinsic unbalance of the wheel using the following formula:

$$U_i = U_c = m_2 \cdot r \quad (2)$$

6 Checking intrinsic unbalance

6.1 Verification and acceptance

Verify the intrinsic unbalance using the method according to Clause 5.

A grinding wheel is only acceptable if its intrinsic unbalance U_i is less than or equal to the permissible unbalance U_a , i.e.

$$U_i \leq U_a \quad \text{ISO 6103:2005} \quad (3)$$

<https://standards.iteh.ai/catalog/standards/sist/64133631-a547-45b5-92dc-d3c17f78e1e2/iso-6103-2005>

The testing is done with a mass

$$m_a = \frac{U_a}{r} \quad (4)$$

6.2 Determination of m_a

From Table 1, determine the coefficient k by reading off the value according to the various parameters related to the grinding wheel and its application.

Figure 5 then gives the values of the mass m_a , in grams, as a function of the mass m_1 of the wheel, in grams, and the coefficient k .

6.3 Acceptance testing of the grinding wheel

With the grinding wheel mounted in accordance with Clause 5, place a mass m_a as determined in 6.2 on the periphery of the grinding wheel at the mark. If the wheel remains stationary or rotates so that the mark is at the bottom, the grinding wheel is accepted; otherwise, it is rejected.