



Designation: A 536 – 84 (Reapproved 2004)

## Standard Specification for Ductile Iron Castings<sup>1</sup>

This standard is issued under the fixed designation A 536; the number immediately following the designation indicates the year of original adoption or, in the case of revision, the year of last revision. A number in parentheses indicates the year of last reapproval. A superscript epsilon ( $\epsilon$ ) indicates an editorial change since the last revision or reapproval.

*This standard has been approved for use by agencies of the Department of Defense.*

### 1. Scope

1.1 This specification covers castings made of ductile iron, also known as spheroidal or nodular iron, that is described as cast iron with the graphite substantially spheroidal in shape and essentially free of other forms of graphite, as defined in Terminology A 644.

1.2 The values stated in inch-pound units are to be regarded as the standard.

1.3 No precise quantitative relationship can be stated between the properties of the iron in various locations of the same casting or between the properties of castings and those of a test specimen cast from the same iron (see Appendix X1).

### 2. Referenced Documents

#### 2.1 ASTM Standards:<sup>2</sup>

A 370 Test Methods and Definitions for Mechanical Testing of Steel Products

A 644 Terminology Relating to Iron Castings

A 732/A 732M Specification for Castings, Investment, Carbon and Low Alloy Steel for General Application, and Cobalt Alloy for High Strength at Elevated Temperatures

E 8 Test Methods for Tension Testing of Metallic Materials

#### 2.2 Military Standard:<sup>3</sup>

MIL-STD-129 Marking for Shipment and Storage

### 3. Ordering Information

3.1 Orders for material to this specification shall include the following information:

3.1.1 ASTM designation,

3.1.2 Grade of ductile iron required (see Table 1, and Sections 4 and 9),

<sup>1</sup> This specification is under the jurisdiction of the ASTM Committee A04 on Castings and is the direct responsibility of Subcommittee A04.02 on Malleable and Ductile Iron Castings.

Current edition approved Oct. 1, 2004. Published October 2004. Originally approved in 1965. Last previous edition approved in 1999 as A 536 – 84 (1999) <sup>$\epsilon$ 1</sup>.

<sup>2</sup> For referenced ASTM standards, visit the ASTM website, www.astm.org, or contact ASTM Customer Service at service@astm.org. For *Annual Book of ASTM Standards* volume information, refer to the standard's Document Summary page on the ASTM website.

<sup>3</sup> Available from Standardization Documents Order Desk, DODSSP, Bldg. 4, Section D, 700 Robbins Ave., Philadelphia, PA 19111-5098

3.1.3 Special properties, if required (see Section 7),

3.1.4 If a different number of samples are required (see Section 10),

3.1.5 Certification, if required (see Section 14), and

3.1.6 Special preparation for delivery, if required (see Section 15).

### 4. Tensile Requirements

4.1 The iron represented by the test specimens shall conform to the requirements as to tensile properties presented in Tables 1 and 2. The irons listed in Table 1 cover those in general use, while those listed in Table 2 are used for special applications (such as pipes, fittings, etc.).

4.2 The yield strength shall be determined at 0.2 % offset by the offset method (see Test Methods E 8). Other methods may be used by mutual consent of the manufacturer and purchaser.

### 5. Heat Treatment

5.1 The 60-40-18 grade will normally require a full ferritizing anneal. The 120-90-02 and the 100-70-03 grades generally require a quench and temper or a normalize and temper, or an isothermal heat treatment. The other two grades can be met either as-cast or by heat treatment. Ductile iron, which is heat treated by quenching to martensite and tempering, may have substantially lower fatigue strength than as-cast material of the same hardness.

### 6. Test Coupons

6.1 The separately cast test coupons from which the tension test specimens are machined shall be cast to the size and shape shown in Fig. 1 or Fig. 2. A modified keel block cast from the mold shown in Fig. 3 may be substituted for the 1-in. Y-block or the 1-in. keel block. The test coupons shall be cast in open molds made of suitable core sand having a minimum wall thickness of 1½ in. (38 mm) for the ½-in. (12.5 mm) and 1-in. (25-mm) sizes and 3 in. (75 mm) for the 3-in. size. The coupons shall be left in the mold until they have cooled to a black color (approximately 900°F (482°C) or less). The size of coupon cast to represent the casting shall be at the option of the purchaser. In case no option is expressed, the manufacturer shall make the choice.

**TABLE 1 Tensile Requirements**

	Grade 60-40-18	Grade 65-45-12	Grade 80-55-06	Grade 100-70-03	Grade 120-90-02
Tensile strength, min, psi	60 000	65 000	80 000	100 000	120 000
Tensile strength, min, MPa	414	448	552	689	827
Yield strength, min, psi	40 000	45 000	55 000	70 000	90 000
Yield strength, min, MPa	276	310	379	483	621
Elongation in 2 in. or 50 mm, min, %	18	12	6.0	3.0	2.0

**TABLE 2 Tensile Requirements for Special Applications**

	Grade 60-42-10	Grade 70-50-05	Grade 80-60-03
Tensile strength, min, psi	60 000	70 000	80 000
Tensile strength, min, MPa	415	485	555
Yield strength, min, psi	42 000	50 000	60 000
Yield strength, min, MPa	290	345	415
Elongation in 2 in. or 50 mm, min, %	10	5	3

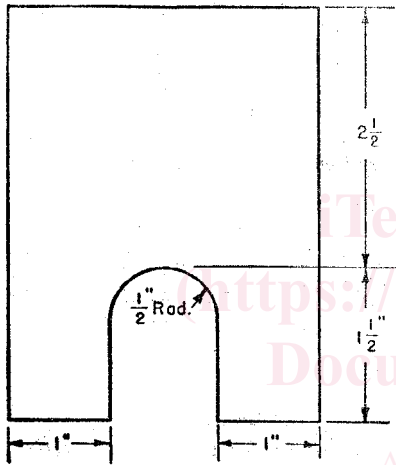
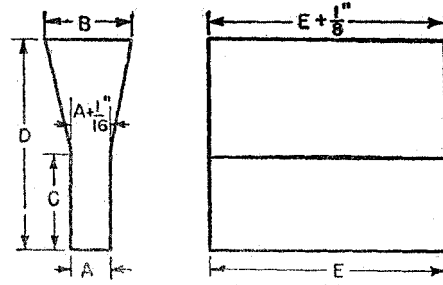

Metric Equivalents

in.	mm	in.	mm
1/2	12.7	1 1/2	38.1
1	25.4	2 1/2	63.5

NOTE—The length of the keel block shall be 6 in. (152 mm).

**FIG. 1 Keel Block for Test Coupons**

6.2 When investment castings are made to this specification, the manufacturer may use test specimens cast to size incorporated in the mold with the castings, or separately cast to size using the same type of mold and the same thermal conditions that are used to produce the castings. These test specimens shall be made to the dimensions shown in Fig. 1 of Specification A 732/A 732M or Figs. 5 and 6 of Test Methods and Definitions A 370.

6.3 The manufacturer may use separately cast test coupons or test specimens cut from castings when castings made to this specification are nodularized or inoculated in the mold. Separately cast test coupons shall have a chemistry that is representative of castings produced from the ladle poured and a cooling rate equivalent to that obtained with the test molds shown in Figs. 1 and 2, Figs. 4-6, or Appendix X2. The size (cooling rate) of the coupon chosen to represent the casting should be decided by the purchaser. If test coupon size is not

Dimensions	"Y" Block Size					
	For Castings of Thickness Less Than 1/2 in. (13 mm)		For Castings of Thickness 1/2 in. (13 mm) to 1 1/2 in. (38 mm)		For Castings of Thickness of 1 1/2 in. (38 mm) and Over	
	in.	mm	in.	mm	in.	mm
A	1/2	13	1	25	3	75
B	1 5/8	40	2 1/8	54	5	125
C	2	50	3	75	4	100
D	4	100	6	150	8	200
E	7	175	7	175	7	175
	approx	approx	approx	approx	approx	approx

**FIG. 2 Y-Blocks for Test Coupons**

specified, the manufacturer shall make the choice. When test bars will be cut from castings, test bar location shall be agreed on by the purchaser and manufacturer and indicated on the casting drawing. The manufacturer shall maintain sufficient controls and control documentation to assure the purchaser that properties determined from test coupons or test bars are representative of castings shipped.

6.4 The test coupons shall be poured from the same ladle or heat as the castings they represent.

6.5 Test coupons shall be subjected to the same thermal treatment as the castings they represent.

**7. Special Requirements**

7.1 When specified in the contract or purchase order, castings shall meet special requirements as to hardness, chemical composition, microstructure, pressure tightness, radiographic soundness, magnetic particle inspection dimensions, and surface finish.

**8. Workmanship, Finish, and Appearance**

8.1 The castings shall be smooth, free of injurious defects, and shall conform substantially to the dimensions of the drawing or pattern supplied by the purchaser.

8.2 Castings shall not have chilled corners or center chill in areas to be machined.

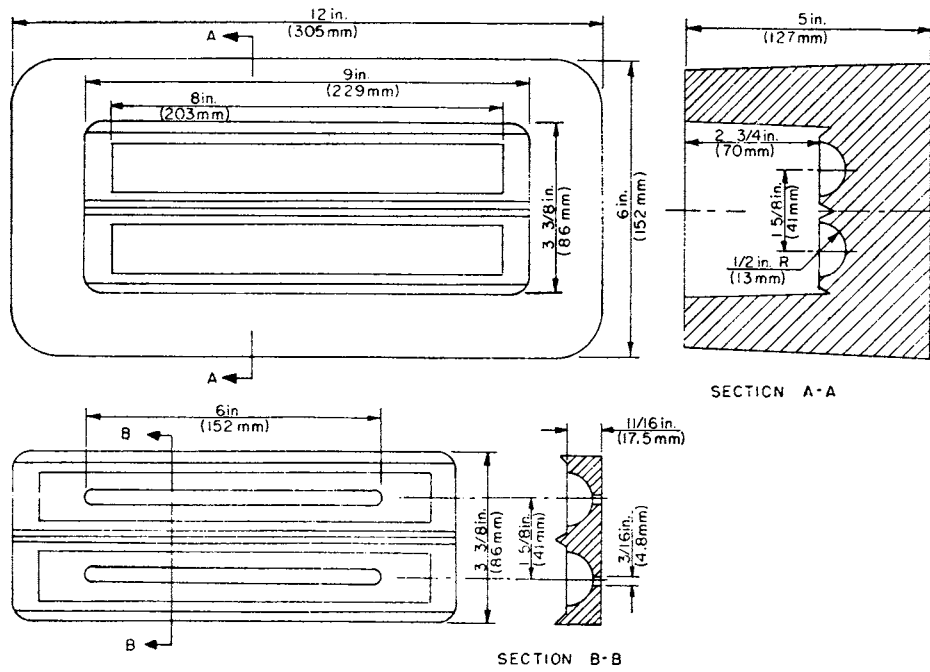
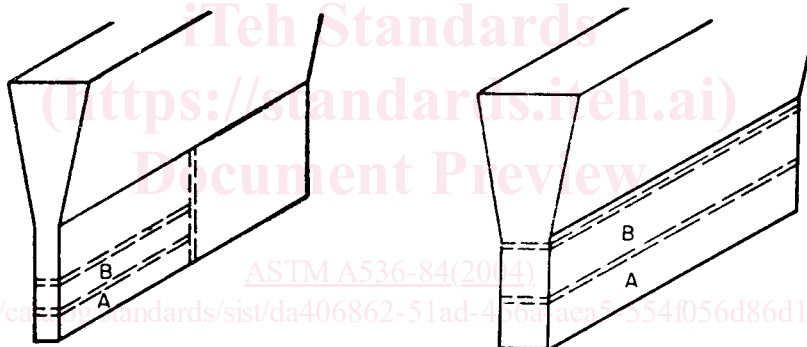
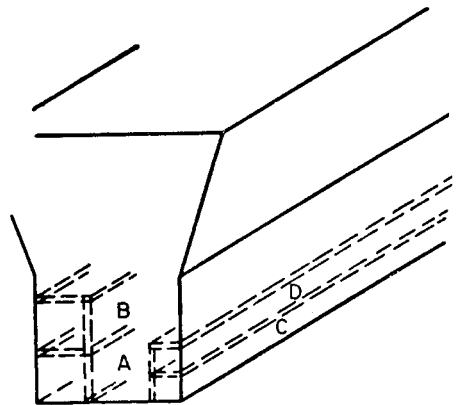

FIG. 3 Mold for Modified Keel Block



(a) 1/2-in. (12.7-mm) Y-block—Two blanks for 0.252-in. (6.40-mm) diameter test specimens.

(b) 1-in. (25.4-mm) Y-Block—Two blanks for 0.50-in. (12.7-mm) diameter tension test specimens.



(c) 3-in. (76.2-mm) Y-Block—Two blanks for 0.50-in. (12.7-mm) diameter tension test specimens.

FIG. 4 Sectioning Procedure for Y-Blocks