

---

# International Standard



# 34

---

INTERNATIONAL ORGANIZATION FOR STANDARDIZATION • МЕЖДУНАРОДНАЯ ОРГАНИЗАЦИЯ ПО СТАНДАРТИЗАЦИИ • ORGANISATION INTERNATIONALE DE NORMALISATION

---

## Rubber, vulcanized — Determination of tear strength (trouser, angle and crescent test pieces)

*Caoutchouc vulcanisé — Détermination de la résistance au déchirement (épreuves pantalon, angulaire et croissant)*

First edition — 1979-10-01

Corrected and reprinted — 1981-03-02

**ITeH STANDARD PREVIEW**  
**(standards.iteh.ai)**

ISO 34:1979

<https://standards.iteh.ai/catalog/standards/sist/0870cdbf-5a2b-4b83-8e8-8db6f8c9df0e/iso-34-1979>

---

UDC 678.01 : 539.412.1

Ref. ISO 34-1979 (E)

**Descriptors** : rubber, vulcanized rubber, mechanical tests, tear tests, test specimens.

## Foreword

ISO (the International Organization for Standardization) is a worldwide federation of national standards institutes (ISO member bodies). The work of developing International Standards is carried out through ISO technical committees. Every member body interested in a subject for which a technical committee has been set up has the right to be represented on that committee. International organizations, governmental and non-governmental, in liaison with ISO, also take part in the work.

Draft International Standards adopted by the technical committees are circulated to the member bodies for approval before their acceptance as International Standards by the ISO Council.

International Standard ISO 34 was developed by Technical Committee ISO/TC 45, *Rubber and rubber products*, and was circulated to the member bodies in February 1977.

It has been approved by the member bodies of the following countries :  
<https://standards.iteh.ai/catalog/standards/sist/0870cdbf-5a2b-4b83-8ef8-8db6f8c9df0e/iso-34-1979>

Austria	Ireland	Sweden
Belgium	Italy	Switzerland
Bulgaria	Mexico	Thailand
Canada	Netherlands	Turkey
Czechoslovakia	Poland	United Kingdom
Germany, F. R.	Romania	USSR
Greece	South Africa, Rep. of	Yugoslavia
India	Sri Lanka	

The member body of the following country expressed disapproval of the document on technical grounds :

France

This International Standard cancels and replaces ISO Recommendation R 34-1957 of which it constitutes a technical revision.

# Rubber, vulcanized — Determination of tear strength (trouser, angle and crescent test pieces)

## 1 Scope and field of application

This International Standard specifies three test methods for the determination of the tear strength of vulcanized rubber, namely

- Method A, based on the use of a trouser test piece;
- Method B, based on the use of an angle test piece, with or without a nick of specified depth;
- Method C, based on the use of a crescent test piece.

The value of tear strength obtained depends on the shape of the test piece, speed of stretching and temperature of test. It may also be susceptible to grain effects in vulcanized rubber.

### Method A : using trouser test piece

Method A, using the trouser test piece, is preferred because it is not sensitive to the length of the cut, unlike the other two test pieces in which the nick has to be very closely controlled. In addition, the results obtained are more easily related to the fundamental tear properties of the material and are less sensitive to modulus effects (provided that the leg extension is negligible) and the rate of propagation of the tear is directly related to the rate of grip separation. However, all the methods are reasonably satisfactory in respect of reproducibility and practicability.[1].

### Method B : Procedure (a) : Using angle test piece without nick

The test is a combination of tear initiation and propagation. The stress is built up at the base of the angle until it is sufficient to initiate a tear and then further stresses propagate this tear. But it is only possible to measure the overall force required to rupture the test piece, and therefore, the force cannot be analysed into two components producing (1) initiation and (2) propagation.[3]

### Method B, procedure (b) : Using angle test piece with nick

This test measures the force required to propagate a nick already produced in the test piece. The rate of propagation is not directly correlated with the jaw speed.[2]

### Method C : Using crescent test piece

This test also measures the force required to propagate a nick already produced in the test piece and the rate of propagation is not correlated with the jaw speed.

NOTE — A separate method for the determination of tear strength of small test pieces of vulcanized rubbers (Delft test pieces) is specified in ISO 816.

## 2 References

ISO 471, *Rubbers — Standard temperatures, humidities and times for the conditioning and testing of test pieces.*

ISO 816, *Vulcanised rubbers — Determination of tear strength of small test pieces (Delft test pieces).*

ISO 1826, *Rubbers — Time-lapse between vulcanization and testing.*

ISO 4648, *Rubber, vulcanized — Determination of dimensions of test pieces and products for test purposes.*

ISO 6133, *Rubber or plastics — Methods of analysis of multipeak traces.*<sup>1)</sup>

## 3 Principle

The test consists in measuring the force required to completely tear the specified test piece, in continuation of the cut or nick already produced in the test piece or, in the case of method B, procedure (a), completely across the width of the test piece.

The tearing force is applied by means of a tensile testing machine, operated without interruption at a constant rate of traverse until the test piece breaks. Dependent upon the method employed, the maximum or median force achieved is used to calculate the tear strength.

No correlation between data obtained by the alternative test pieces is implied.

1) At present at the stage of draft.

## 4 Definitions

For the purpose of this International Standard, the following definitions apply.

**4.1 trouser tear strength** : The median force calculated in accordance with ISO 6133 required to propagate a cut in a specified trouser-shaped test piece by tearing, the force acting in a direction substantially in the plane of the cut.

**4.2 unnicked angle tear strength** : The maximum force required to rupture a specified angle-shaped test piece, the force acting in a direction substantially along the length of the test piece.

**4.3 nicked angle or crescent tear strength** : The maximum force required to cause a nick cut in a specified angle- or crescent-shaped test piece to extend by tearing of the rubber, the force acting in a direction substantially normal to the plane of the nick.

## 5 Apparatus

### 5.1 Dies

**5.1.1** The die used for punching trouser test pieces shall have the outline dimensions as shown in figure 1.

**5.1.2** The die used for punching angle test pieces shall have the dimensions shown in figure 2.

**5.1.3** The die used for punching crescent test pieces shall have the dimensions shown in figure 3.

The cutting edges of the dies shall be kept sharp and free from ragged edges.

### 5.2 Nick cutter

A sharp razor blade or a sharp knife free from ragged edges shall be used for producing a cut or a nick in the test piece.

The trouser test piece shall be cut to a depth of  $40 \pm 5$  mm in the direction indicated in figure 1. It is important that the last 1 mm (approximately) of the cut is made with a razor blade or a sharp knife.

The essentials of a suitable apparatus for introducing the nick required for the nicked angle or crescent test piece are as follows :

Means shall be provided for clamping the test piece firmly, especially in the region where the nick is to be introduced. The cutting tool, consisting of a razor blade or similar blade, shall be clamped in a plane perpendicular to the major axis of the test piece, and positioned so as to introduce the nick in the appropriate place. The blade clamping device shall permit no lateral movement and shall be fitted in guides to enable the blade to be moved across the test piece with its edge remaining perpendicular to the plane of the test piece. Alternatively, the

blade may be fixed and the test piece arranged to move in an analogous manner. Means shall be provided for fine adjustment of the depth of the nick. The adjustment for the position of the blade holder and/or the clamped test piece shall be determined for each blade by cutting one or two preliminary nicks and measuring these with the aid of a microscope. The blade shall be wetted with water or soap solution prior to nicking. A suitable apparatus for nicking tear test pieces has been described in detail in the literature.[4]

To check that the depth of the nick is within the specified limits (see 6.1.4), any suitable means may be used, for example, an optical projection apparatus. A convenient arrangement is a microscope giving at least  $10 \times$  magnification fitted with travelling stage suitably illuminated. The eyepiece is fitted with a graticule or crosswire by which to record the travel of the stage and test piece through a distance equal to the depth of the nick. The travel of the stage is calibrated with a stage micrometer.

Alternatively, a travelling microscope may be used.

The apparatus shall have an accuracy of measurement of 0,025 mm or better.

### 5.3 Testing machine

The machine shall conform to the requirements of national standards for verification of testing machines.

It shall be capable of registering the applied forces within 2 % during the test while maintaining the specified constant rate of separation of the jaws of  $100 \pm 10$  mm/min for the trouser test piece and  $500 \pm 50$  mm/min for the angle and crescent test pieces. A low inertia machine having autographic recording of force is essential when using the trouser test piece.

NOTE — Inertia (Pendulum) type dynamometers are apt to give results which differ one from another because of frictional and inertial effects. A low inertia (for example electronic or optical transducer) type dynamometer gives results which are free from these effects and is therefore to be preferred.

### 5.4 Grips

The machine shall be provided with a type of grip, for example air-actuated grip, which tightens automatically as the tension increases and exerts a uniform pressure across the widened end of the test piece. Each grip shall incorporate a means for positioning so that the test pieces are inserted symmetrically and in axial alignment with the direction of the pull. The depth of insertion shall be such that the test piece is adequately gripped, within the parallel portion, when testing angle and crescent test pieces. Trouser test pieces shall be inserted in the grips in accordance with figure 4.

## 6 Test piece

### 6.1 Dimensions and preparation

**6.1.1** The test piece shall be cut from a sheet by punching with a die, shaped as shown in figure 1, 2 or 3 (the choice

depending upon the selection of the test method), using a single stroke of a press; the rubber may be wetted with water or soap solution and should be supported on a sheet of slightly yielding material (for example leather, rubber belting, or cardboard) on a flat, rigid surface.

**6.1.2** The test piece shall, if possible, be taken in such a way that the tear strength can be determined in two directions which are at an angle of 90° to one another. The directions in which the test piece is taken shall be indicated so that the effect of anisotropy can be assessed.

**6.1.3** The thickness of the test piece shall be preferably  $2 \pm 0,2$  mm and shall be measured in the region of test in accordance with ISO 4648. No reading shall deviate by more than 2 % from the value to be used. If groups of test pieces are being compared, the median thickness of each group shall be within 7,5 % of the grand median thickness of the groups.

**6.1.4** The test piece shall be cut to a depth as given below by the procedure specified in 5.2.

Method A (Trouser test piece) — Cut of depth  $40 \pm 5$  mm at the centre of the width of the test piece.

Method B, Procedure (b) (Angle test piece) — Nick of depth  $1 \pm 0,2$  mm at the apex of the internal angle of the test piece.

Method C, (Crescent test piece) — Nick of depth of  $1 \pm 0,2$  mm at the centre of the concave inner edge of the test piece.

## 6.2 Number

At least five test pieces per sample shall be tested and, where possible, five from each of the directions referred to in 6.1.2.

## 7 Time-interval between vulcanization and testing

The requirements of ISO 1826 apply. The maximum allowable period between nicking of test piece and testing shall not exceed 24 h.

## 8 Conditioning of test pieces

**8.1** The test pieces shall be protected from light as completely as possible during the interval between vulcanization and testing.

**8.2** The test pieces shall be conditioned, after any preparation as necessary, at a standard laboratory temperature (see ISO 471) for at least 3 h before they are cut or nicked. These test pieces may be nicked, measured and tested immediately but, if not tested immediately, they shall be kept at  $23 \pm 2$  °C or  $27 \pm 2$  °C, as the case may be, until tested. If the preparation involves buffing, the interval between buffing and testing shall not exceed 72 h.

The cut or nick shall be made after any ageing treatment has been carried out.

**8.3** If the test is to be carried out at a temperature other than a standard laboratory temperature, the test pieces shall be conditioned for a period sufficient to reach substantial temperature equilibrium at the test temperature, immediately prior to testing. This period shall be kept as short as possible in order to avoid ageing the rubber.

## 9 Temperature of test

The test shall normally be carried out at a standard laboratory temperature of  $23 \pm 2$  °C or  $27 \pm 2$  °C, specified in 3.2 of ISO 471 (1977). When other temperatures are required these shall be selected from ISO 471.

The same temperature shall be used throughout any one test or series of tests intended to be comparable.

## 10 Procedure

After conditioning as described in clause 8, immediately mount the test piece in the testing machine (5.3) as described in 5.4. Apply a steadily increasing traction force at a rate of separation of the grips of  $500 \pm 50$  mm/min for angle and crescent type test pieces and  $100 \pm 10$  mm/min for trouser test pieces until the test piece breaks. Record the maximum force for crescent and angle test pieces. When using the trouser test piece make an autographic recording of the force throughout the tearing process.

## 11 Expression of results

The tear strength  $T_s$  is given, in kilonewtons per metre of thickness, by the formula

$$T_s = \frac{F}{d}$$

where

$F$  is the maximum force, in newtons, in case of methods B and C, and the median force, in newtons, calculated in accordance with ISO 6133, when using method A;

$d$  is the thickness, in millimetres, of the test piece.

Determine the median and the range of the values for each direction.

Express the results to the nearest kN/m.

## 12 Test report

The test report shall include the following particulars :

- a reference to this International Standard;
- the identification of the sample;

- c) the type of test piece used;
- d) the median and range of values of tear strength, in kilonewtons per metre, calculated in accordance with clause 11, for each direction of all individual results;
- e) the median thickness of the test piece;
- f) the direction of tension relative to grain in the rubber;
- g) the temperature of test;
- h) any special characteristics of the test pieces during the test and their condition after the test, for example direction of nick propagation; and for method B, whether nicked or unnicked;
- i) the date of vulcanization, if known, and the date of testing.

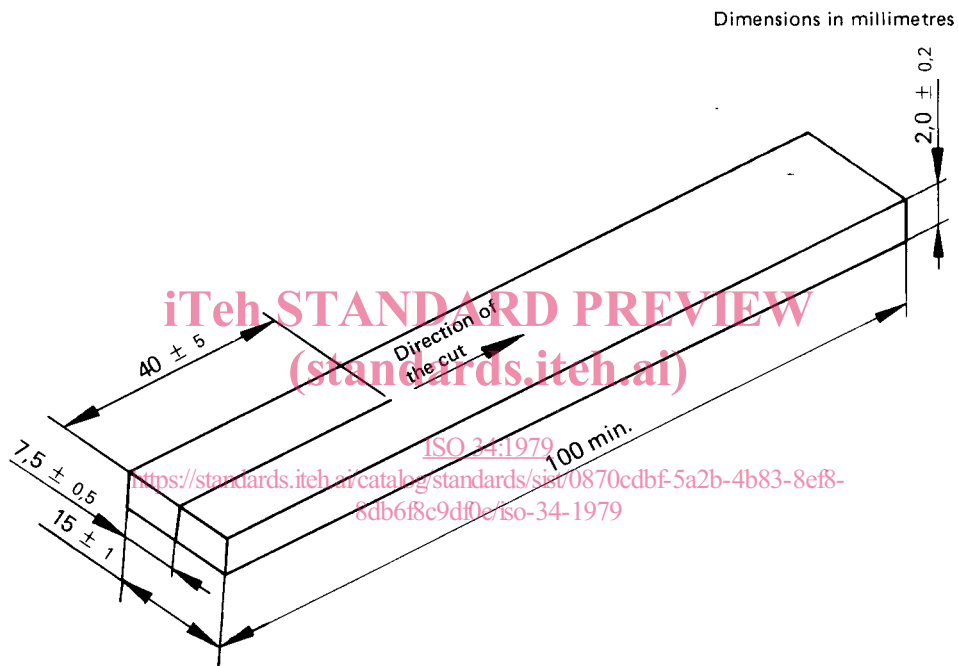

Figure 1 — Trouser test piece

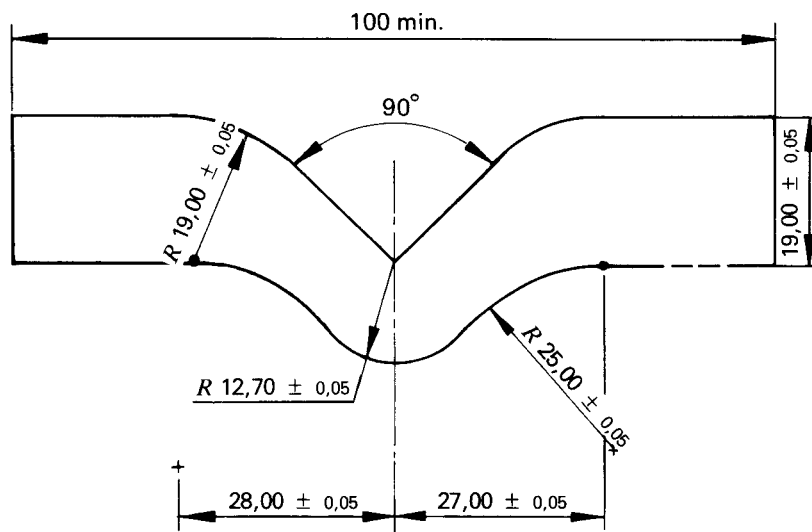

Figure 2 — Angle test piece die

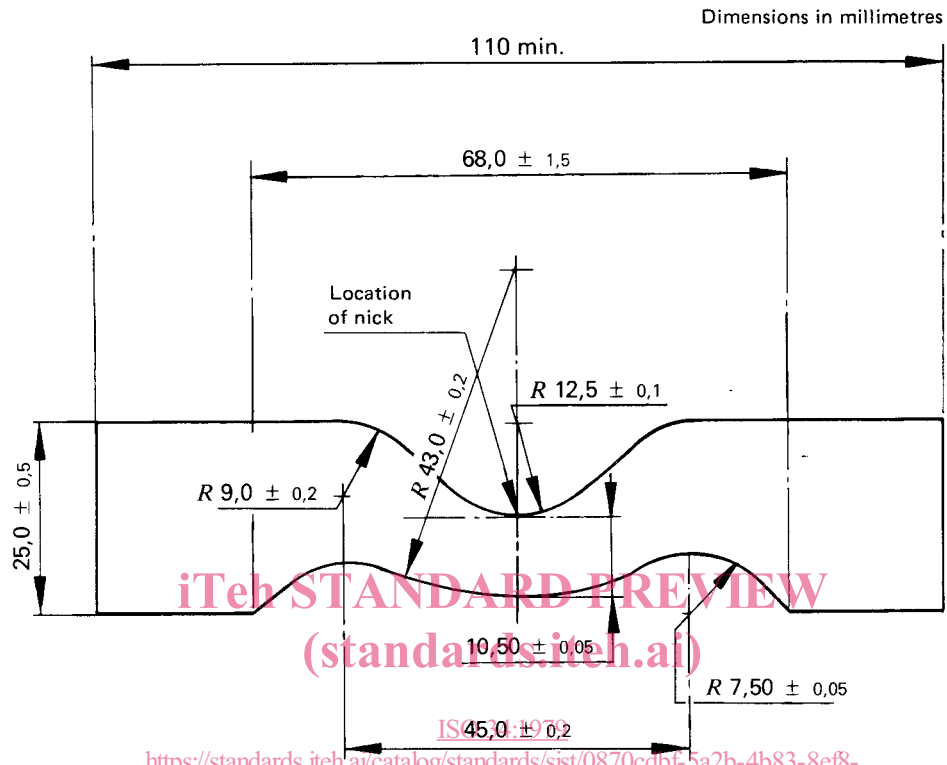

Figure 3 – Crescent test piece die

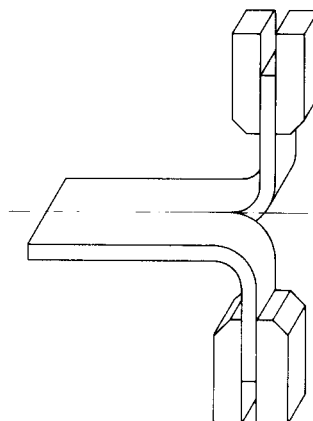

Figure 4 – Positioning of trouser test piece in testing machine

## Bibliography

- [ 1 ] CLAMROTH, R., and EISELE, W., *Kautschuk, Gummi, Kunststoffe*. **28**, 433 (1975).
- [ 2 ] KAINRADL, P., and HANDLER, F., *Rubber Chemistry and Technology*. **33**, 1438 (1960).
- [ 3 ] BUIST, J. M., *Rubber Chemistry and Technology*. **23**, 137 (1950).
- [ 4 ] BUIST, J. M., and KENNEDY, R.L., *India Rubber Journal*. **110**, 809 (1946).

---

**iTeh STANDARD PREVIEW**  
**(standards.iteh.ai)**

[ISO 34:1979](#)

<https://standards.iteh.ai/catalog/standards/sist/0870cdbf-5a2b-4b83-8ef8-8db6f8c9df0e/iso-34-1979>





Published 1981-02-15

# Rubber, vulcanized — Determination of tear strength (trouser, angle and crescent test pieces)

## ERRATUM

Page 1

### Title

In the first element, insert a comma between "Rubber" and "vulcanized".

### 1 Scope and field of application

#### Method A : using trouser test piece

In line 5, delete "test", and substitute "tear".

**iTeh STANDARD PREVIEW**  
**(standards.iteh.ai)**

ISO 34:1979

<https://standards.iteh.ai/catalog/standards/sist/0870cdbf-5a2b-4b83-8ef8-8db6f8c9df0e/iso-34-1979>