

INTERNATIONAL  
STANDARD

**ISO**  
**34-1**

First edition  
1994-02-15

---

---

**Rubber, vulcanized or thermoplastic —  
Determination of tear strength —**

**Part 1:**

**Trouser, angle and crescent test pieces  
(standards.iteh.ai)**

*Caoutchouc vulcanisé ou thermoplastique — Détermination de la  
résistance au déchirement —  
Partie 1: Éprouvettes pantalon, angulaire et croissant*

INTERNATIONAL

ISO



Reference number  
ISO 34-1:1994(E)

## Foreword

ISO (the International Organization for Standardization) is a worldwide federation of national standards bodies (ISO member bodies). The work of preparing International Standards is normally carried out through ISO technical committees. Each member body interested in a subject for which a technical committee has been established has the right to be represented on that committee. International organizations, governmental and non-governmental, in liaison with ISO, also take part in the work. ISO collaborates closely with the International Electrotechnical Commission (IEC) on all matters of electrotechnical standardization.

Draft International Standards adopted by the technical committees are circulated to the member bodies for voting. Publication as an International Standard requires approval by at least 75 % of the member bodies casting a vote.

International Standard ISO 34-1 was prepared by Technical Committee ISO/TC 45, *Rubber and rubber products*, Sub-Committee SC 2, *Physical and degradation tests*.

<https://standards.iteh.ai/catalog/standards/sist/2bd412f2-e561-4920-be6f-1920-1979>

This first edition cancels and replaces ISO 34:1979, of which it constitutes a minor technical revision.

ISO 34 consists of the following parts, under the general title *Rubber, vulcanized or thermoplastic — Determination of tear strength*:

— Part 1: *Trouser, angle and crescent test pieces*

— Part 2: *Small (Delft) test pieces*

Part 2 will be a revision of ISO 816:1983.

Annexes A, B and C of this part of ISO 34 are for information only.

© ISO 1994

All rights reserved. No part of this publication may be reproduced or utilized in any form or by any means, electronic or mechanical, including photocopying and microfilm, without permission in writing from the publisher.

International Organization for Standardization  
Case Postale 56 • CH-1211 Genève 20 • Switzerland

Printed in Switzerland

# Rubber, vulcanized or thermoplastic — Determination of tear strength —

## Part 1:

### Trouser, angle and crescent test pieces

#### 1 Scope

This part of ISO 34 specifies three test methods for the determination of the tear strength of vulcanized rubber, namely

- Method A, using a trouser test piece;
- Method B, using an angle test piece, with or without a nick of specified depth;
- Method C, using a crescent test piece with a nick.

The value of tear strength obtained depends on the shape of the test piece, speed of stretching and temperature of test. It may also be susceptible to grain effects in vulcanized rubber.

##### Method A: Using a trouser test piece

Method A, using the trouser test piece, is preferred because it is not sensitive to the length of the cut, unlike the other two test pieces in which the nick has to be very closely controlled. In addition, the results obtained are more easily related to the fundamental tear properties of the material and are less sensitive to modulus effects (provided that the leg extension is negligible) and the rate of propagation of the tear is directly related to the rate of grip separation. With some rubbers, the propagation of tear is not smooth (knotty tear), and analysis of results may be difficult.

##### Method B, procedure (a): Using an angle test piece without nick

This test is a combination of tear initiation and propagation. Stress is built up at the point of the angle until it is sufficient to initiate a tear and then further stresses propagate this tear. But it is only possible to measure the overall force required to rupture the test

piece, and, therefore, the force cannot be resolved into two components producing (1) initiation and (2) propagation. [1]

##### Method B, procedure (b): Using an angle test piece with nick

This test measures the force required to propagate a nick already produced in the test piece. The rate of propagation is not directly related to the jaw speed. [2]

##### Method C: Using a crescent test piece

This test also measures the force required to propagate a nick already produced in the test piece and the rate of propagation is not related to the jaw speed.

NOTE 1 A separate method for the determination of the tear strength of small test pieces of vulcanized rubber (Delft test pieces) is specified in ISO 816:1983, *Rubber, vulcanized — Determination of tear strength of small test pieces (Delft test pieces)* (to be ISO 34-2).

#### 2 Normative references

The following standards contain provisions which, through reference in this text, constitute provisions of this part of ISO 34. At the time of publication, the editions indicated were valid. All standards are subject to revision, and parties to agreements based on this part of ISO 34 are encouraged to investigate the possibility of applying the most recent editions of the standards indicated below. Members of IEC and ISO maintain registers of currently valid International Standards.

ISO 471:1983, *Rubber — Standard temperatures, humidities and times for the conditioning and testing of test pieces*.

ISO 1826:1981, *Rubber, vulcanized — Time-interval between vulcanization and testing — Specification.*

ISO 3383:1985, *Rubber — General directions for achieving elevated or subnormal temperatures for test purposes.*

ISO 4648:1991, *Rubber, vulcanized or thermoplastic — Determination of dimensions of test pieces and products for test purposes.*

ISO 5893:1993, *Rubber and plastics test equipment — Tensile, flexural and compression types (constant rate of traverse) — Description.*

ISO 6133:1981, *Rubber and plastics — Analysis of multi-peak traces obtained in determinations of tear strength and adhesion strength.*

ISO/TR 9272:1986, *Rubber and rubber products — Determination of precision for test method standards.*

### 3 Definitions

For the purposes of this part of ISO 34, the following definitions apply.

**3.1 trouser tear strength:** The median force, calculated in accordance with ISO 6133, required to propagate a cut in a specified trouser-shaped test piece by tearing, divided by the thickness of the test piece, the force acting in a direction substantially in the plane of the cut.

**3.2 unnicked angle tear strength:** The maximum force required to rupture a specified angle-shaped test piece, divided by the thickness of the test piece, the force acting in a direction substantially along the length of the test piece.

**3.3 nicked angle or crescent tear strength:** The maximum force required to cause a nick cut in a specified angle- or crescent-shaped test piece to extend by tearing of the rubber, divided by the thickness of the test piece, the force acting in a direction substantially normal to the plane of the nick.

### 4 Principle

The test consists in measuring the force required to tear a specified test piece, in continuation of the cut or nick already produced in the test piece or, in the case of method B, procedure (a), completely across the width of the test piece.

The tearing force is applied by means of a tensile testing machine, operated without interruption at a constant rate of traverse until the test piece breaks. Dependent upon the method employed, the maximum or median force achieved is used to calculate the tear strength.

No correlation between data obtained by the alternative test pieces is implied.

## 5 Apparatus

### 5.1 Dies.

**5.1.1** The die used for cutting trouser test pieces shall have the outline dimensions shown in figure 1.

**5.1.2** The die used for cutting angle test pieces shall have the dimensions shown in figure 2.

**5.1.3** The die used for cutting crescent test pieces shall have the dimensions shown in figure 3.

**5.1.4** The cutting edges of the dies shall be kept sharp and free from ragged edges. Care shall be taken that the cutting edges are perpendicular to the other surfaces of the die and have a minimum of concavity.

### 5.2 Nick cutter.

A sharp razor blade or a sharp knife free from ragged edges shall be used for producing a cut or a nick in the test piece.

The trouser test piece shall be cut to a depth of  $40 \text{ mm} \pm 5 \text{ mm}$  in the direction indicated in figure 1. It is important that the last 1 mm (approximately) of the cut is made with a razor blade or a sharp knife.

The essentials of a suitable apparatus for introducing the nick required for the nicked angle or crescent test piece are as follows:

Means shall be provided for clamping the test piece firmly, especially in the region where the nick is to be introduced. The cutting tool, consisting of a razor blade or similar blade, shall be clamped in a plane perpendicular to the major axis of the test piece, and positioned so as to introduce the nick in the appropriate place. The blade clamping device shall permit no lateral movement and shall be fitted in guides to enable the blade to be moved across the test piece with its edge remaining perpendicular to the plane of the test piece. Alternatively, the blade may be fixed and the test piece arranged to move in an analogous manner. Means shall be provided for fine adjustment of the depth of the nick. The adjustment of the position of the blade holder and/or clamped test piece shall be determined for each blade by cutting one or two preliminary nicks and measuring these with the aid of a microscope. The blade shall be wetted with water or soap solution prior to nicking. A suitable apparatus for nicking tear test pieces has been described in detail in the literature. [3]

To check that the depth of the nick is within the specified limits (see 6.4), any suitable means may be used, for example an optical projection apparatus. A

convenient arrangement is a microscope giving at least  $\times 10$  magnification fitted with a travelling stage suitably illuminated. The eyepiece is fitted with a graticule or crosswire by which to record the travel of the stage and test piece through a distance equal to the depth of the nick. The travel of the stage is calibrated with a stage micrometer.

Alternatively, a travelling microscope may be used.

The apparatus shall have an accuracy of measurement of 0,05 mm.

### 5.3 Testing machine.

The machine shall conform to the requirements of ISO 5893, to an accuracy corresponding to grade B.

It shall be capable of registering the applied forces within 2 % during the test while maintaining the specified constant rate of separation of the jaws of 100 mm/min  $\pm$  10 mm/min for the trouser test piece and 500 mm/min  $\pm$  50 mm/min for the angle and crescent test pieces. A low-inertia machine having autographic force-recording facilities is essential when using the trouser test piece.

NOTE 2 Inertia (pendulum) type dynamometers are apt to give results which differ from each other because of frictional and inertial effects. A low-inertia (for example electronic- or optical-transducer) type dynamometer gives results which are free from these effects and is therefore to be preferred.

### 5.4 Grips.

The machine shall be provided with a type of grip which tightens automatically as the tension increases and exerts a uniform pressure across the widened end of the test piece. Each grip shall incorporate a means for positioning so that the test pieces are inserted symmetrically and in axial alignment with the direction of the pull. The depth of insertion shall be such that the test piece is adequately gripped, within the parallel-sides portion, when testing angle and crescent test pieces. Trouser test pieces shall be inserted in the grips in accordance with figure 4.

## 6 Test pieces

**6.1** Test pieces shall be cut from sheet of uniform thickness. Preferably the sheet shall have a thickness of 2,0 mm  $\pm$  0,2 mm; however, it is recognized that, when sheets are prepared from certain products, this thickness may not be achievable.

Sheets may be moulded, or prepared from products by cutting and/or buffing.

The requirements of ISO 1826 shall apply to the time-interval between vulcanization or preparation of the sheet and cutting of test pieces. During this in-

terval, the sheets shall be protected from light as completely as possible.

**6.2** The sheets shall be conditioned at standard temperature (see ISO 471) for at least 3 h before test pieces are cut from them.

Each test piece shall be cut from the sheet by punching with a die, shaped as shown in figure 1, 2 or 3, the choice depending upon the test method, using a single stroke of the press. The rubber may be wetted with water or soap solution and shall be supported on a sheet of slightly yielding material (for example leather, rubber belting or cardboard) on a flat rigid surface.

**6.3** Each test piece shall, if possible, be taken in such a way that the tear strength can be determined in two directions which are at an angle of 90° to one another. The directions in which the test piece is taken shall be indicated so that the effect of anisotropy can be assessed.

The direction of tear propagation will be parallel to the length of the test piece for the trouser test piece and perpendicular for angle and crescent test pieces.

**6.4** Each test piece shall be cut or nicked to a depth as given below by the apparatus specified in 5.2.

Method A (trouser test piece) — Cut of depth 4,0 mm  $\pm$  0,5 mm at the centre of the width of the test piece.

Method B, procedure (b) (angle test piece) — Nick of depth 1,0 mm  $\pm$  0,2 mm at the apex of the internal angle of the test piece.

Method C (crescent test piece) — Nick of depth 1,0 mm  $\pm$  0,2 mm at the centre of the concave inner edge of the test piece.

Test pieces may be nicked, measured and then tested immediately, but if not tested immediately they shall be kept at 23 °C  $\pm$  2 °C or 27 °C  $\pm$  2 °C, as the case may be, until tested. The period between nicking of the test piece and testing shall not exceed 24 h. The cut or nick shall be made after any ageing treatment has been carried out.

## 7 Number of tests

At least five test pieces per sample shall be tested and, where possible, five from each of the directions referred to in 6.3.

## 8 Temperature of test

The test is normally carried out at a standard temperature of 23 °C  $\pm$  2 °C or 27 °C  $\pm$  2 °C, as specified in ISO 471. When other temperatures are required, these shall be selected from ISO 471.



If the test is to be carried out at a temperature other than a standard temperature, the test piece shall be conditioned for a period sufficient to reach substantial temperature equilibrium at the test temperature, immediately prior to testing. This period shall be kept as short as possible in order to avoid ageing the rubber (see ISO 3383).

The same temperature shall be used throughout any one test or series of tests intended to be comparable.

## 9 Procedure

Measure the thickness of the test piece in the region in which tearing is expected to occur, in accordance with ISO 4648. No measurement on any one test piece shall deviate by more than 2 % from the median value of the thickness of that test piece. If groups of test pieces are being compared, the median thickness of each group shall be within 1,5 % of the grand median thickness of all the groups.

After conditioning as described in clause 8, immediately mount the test piece in the testing machine (5.3) as described in 5.4. Apply a steadily increasing traction force at a rate of separation of the grips of 500 mm/min  $\pm$  50 mm/min for angle and crescent type test pieces and 100 mm/min  $\pm$  10 mm/min for trouser test pieces until the test piece breaks. Record the maximum force for crescent and angle test pieces. When using trouser test pieces, make an autographic recording of the force throughout the tearing process.

## 10 Expression of results

The tear strength  $T_s$ , expressed in kilonewtons per metre of thickness, is given by the formula

$$T_s = \frac{F}{d}$$

where

$F$  is the maximum force, in newtons, when using methods B and C, and the median force, in newtons, calculated in accordance with ISO 6133, when using method A;

$d$  is the median thickness, in millimetres, of the test piece.

Determine the median and the range of the values for each direction.

Express the results to the nearest kilonewton per metre (kN/m).

## 11 Precision

### 11.1 General

The precision calculations to express repeatability and reproducibility were performed in accordance with ISO/TR 9272. Consult this for precision concepts and nomenclature. Annex A gives guidance on the use of repeatability and reproducibility results.

### 11.2 Precision details

**11.2.1** An interlaboratory test programme (ITP) was organized for this test method in 1987. Cured test sheets (plates) were sent out to all participating laboratories using three compounds: A, B and C. Details of these compounds are outlined in annex B. In each laboratory the following operations were carried out: test piece cutting, test piece nicking (if required), thickness measuring and, finally, tear strength measurement.

**11.2.2** A total of 25 laboratories conducted tests for Die B and Die C, while 22 laboratories conducted tests on the trouser test pieces. For all test pieces, tests were conducted on each of two "test days" one week apart. A test result (as used for the analysis) consists of the median value of five individual tear tests. The precision evaluated is a Type 1 precision; no mixing or curing of compounds was done in the participating laboratories.

### 11.3 Precision results

The precision results for all tests are given in table 1. See annex A for guidance on using precision results.

The symbols used in table 1 are as follows:

$r$  = repeatability, measurement units

$(r)$  = repeatability, as percentage of material average

$R$  = reproducibility, measurement units

$(R)$  = reproducibility, as percentage of material average

Pooled  $(r)$  and  $(R)$  values are calculated on the basis of pooled  $r$  and  $R$  and overall material average values.

## 12 Test report

The test report shall include the following particulars:

- a reference to this International Standard;
- all details necessary for identification of the sample;

- c) the type of test piece used;
- d) the median and range of values of tear strength, in kilonewtons per metre, calculated in accordance with clause 10, for each direction, plus all the individual results;
- e) the median thickness of each test piece;
- f) the direction of the applied force relative to the grain in the rubber;
- g) the temperature of test;
- h) for method B, whether the test piece was nicked or unnicked;
- i) any special characteristics of the test pieces noted during the test and their condition after the test, for example direction of nick propagation;
- j) the date of vulcanization, if known, and the date of testing.

**iTeh STANDARD PREVIEW**  
**(standards.iteh.ai)**

ISO 34-1:1994

<https://standards.iteh.ai/catalog/standards/sist/2bd412f2-e561-4920-be6f-cf82e238ee4f/iso-34-1-1994>

**Table 1 — Type 1 precision results for tear strength (kN/m)**

Material	Average	Within-laboratory		Between-laboratory	
		<i>r</i>	( <i>r</i> )	<i>R</i>	( <i>R</i> )
<b>Trouser tear</b>					
Direction 1 (mill "grain" perpendicular)					
Compound A	3,68	0,91	24,7	1,29	35,0
Compound B	7,67	1,96	25,5	2,36	30,8
Compound C	22,8	8,66	38,0	13,80	60,7
Pooled values	11,3	5,15	45,6	8,15	72,1
Direction 2 (mill "grain" parallel)					
Compound A	4,81	2,32	48,3	2,61	54,3
Compound B	8,34	2,92	35,0	2,92	35,0
Compound C	27,3	11,60	42,5	13,50	49,6
Pooled values	13,6	7,10	52,1	8,15	59,8
<b>Die "B" tear</b>					
Without nick					
Compound A	38,1	4,54	12,1	20,2	53,0
Compound B	44,5	7,12	15,9	20,4	45,9
Compound C	98,7	43,3	43,8	47,9	48,6
Pooled values	60,4	25,8	42,7	31,7	52,5
With nick					
Compound A	13,2	3,90	29,4	4,74	35,7
Compound B	14,7	6,02	40,8	6,02	40,8
Compound C	62,1	29,10	49,6	37,80	60,9
Pooled values	30,2	17,4	57,6	22,2	73,7
<b>Die "C" tear</b>					
Nick = 90° angle cut					
Compound A	29,9	6,84	22,8	31,0	103,7
Compound B	31,1	4,70	15,1	29,4	94,6
Compound C	124,0	29,20	23,5	47,1	38,0
Pooled values	61,6	17,5	28,4	36,7	59,6



Dimensions in millimetres

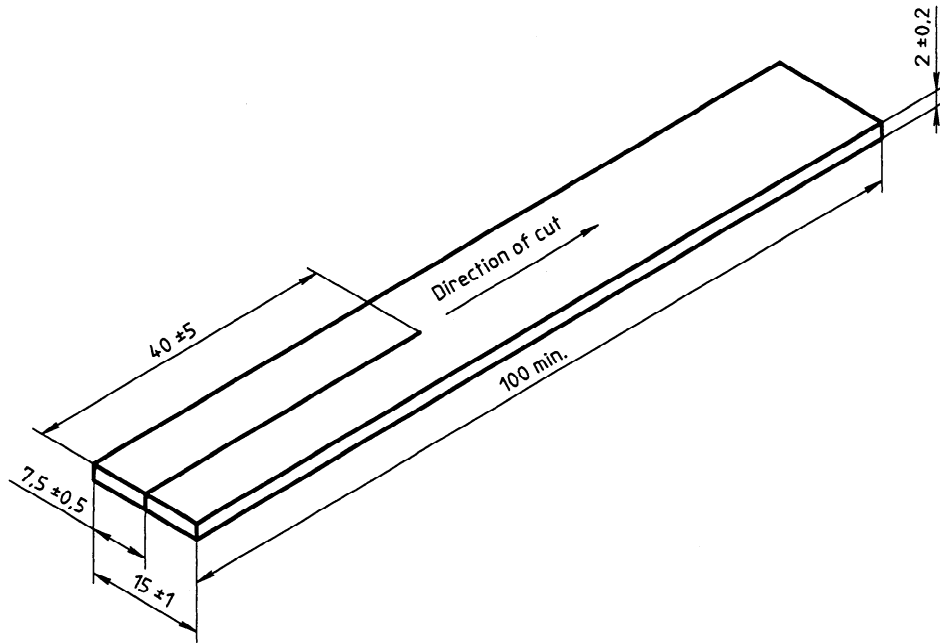

**Figure 1 — Trouser test piece die**  
**iTeh STANDARD PREVIEW**  
**(standards.iteh.ai)**

Dimensions in millimetres

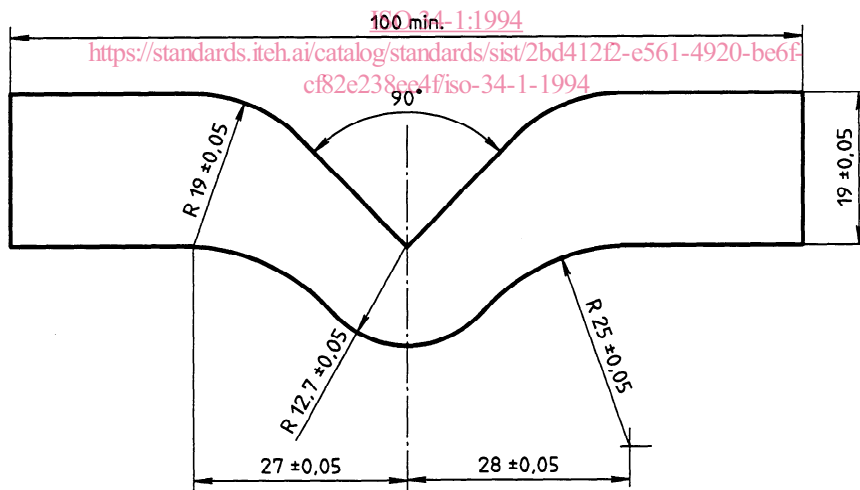

**Figure 2 — Angle test piece die**