**Diesel engines — High-pressure fuel
injection pipe end-connections with 60°
female cone**

*Moteurs diesels — Raccords finaux à cône femelle de 60° pour lignes
d'injection de combustible haute pression*

iTeh STANDARD PREVIEW
(standards.iteh.ai)

[ISO 2974:2005](#)

<https://standards.iteh.ai/catalog/standards/sist/ee3fedce-1c6f-484a-8c98-5a2079d30520/iso-2974-2005>



PDF disclaimer

This PDF file may contain embedded typefaces. In accordance with Adobe's licensing policy, this file may be printed or viewed but shall not be edited unless the typefaces which are embedded are licensed to and installed on the computer performing the editing. In downloading this file, parties accept therein the responsibility of not infringing Adobe's licensing policy. The ISO Central Secretariat accepts no liability in this area.

Adobe is a trademark of Adobe Systems Incorporated.

Details of the software products used to create this PDF file can be found in the General Info relative to the file; the PDF-creation parameters were optimized for printing. Every care has been taken to ensure that the file is suitable for use by ISO member bodies. In the unlikely event that a problem relating to it is found, please inform the Central Secretariat at the address given below.

iTeh STANDARD PREVIEW
(standards.iteh.ai)

[ISO 2974:2005](#)

<https://standards.iteh.ai/catalog/standards/sist/ee3fedce-1c6f-484a-8c98-5a2079d30520/iso-2974-2005>

© ISO 2005

All rights reserved. Unless otherwise specified, no part of this publication may be reproduced or utilized in any form or by any means, electronic or mechanical, including photocopying and microfilm, without permission in writing from either ISO at the address below or ISO's member body in the country of the requester.

ISO copyright office
Case postale 56 • CH-1211 Geneva 20
Tel. + 41 22 749 01 11
Fax + 41 22 749 09 47
E-mail copyright@iso.org
Web www.iso.org

Published in Switzerland

Foreword

ISO (the International Organization for Standardization) is a worldwide federation of national standards bodies (ISO member bodies). The work of preparing International Standards is normally carried out through ISO technical committees. Each member body interested in a subject for which a technical committee has been established has the right to be represented on that committee. International organizations, governmental and non-governmental, in liaison with ISO, also take part in the work. ISO collaborates closely with the International Electrotechnical Commission (IEC) on all matters of electrotechnical standardization.

International Standards are drafted in accordance with the rules given in the ISO/IEC Directives, Part 2.

The main task of technical committees is to prepare International Standards. Draft International Standards adopted by the technical committees are circulated to the member bodies for voting. Publication as an International Standard requires approval by at least 75 % of the member bodies casting a vote.

Attention is drawn to the possibility that some of the elements of this document may be the subject of patent rights. ISO shall not be held responsible for identifying any or all such patent rights.

ISO 2974 was prepared by Technical Committee ISO/TC 22, *Road vehicles*, Subcommittee SC 7, *Injection equipment and filters for use on road vehicles*.

This sixth edition cancels and replaces the fifth edition (ISO 2974:2000), Table 1 of which has been technically revised (addition of tube outside diameter of 7 mm).

iTeh STANDARD PREVIEW
(standards.iteh.ai)
<https://standards.iteh.ai/catalog/standards/sist/ee3fedce-1c6f-484a-8c98-5a2079d30520/iso-2974-2005>

iTeh STANDARD PREVIEW
(standards.iteh.ai)

ISO 2974:2005

<https://standards.iteh.ai/catalog/standards/sist/ee3fedce-1c6f-484a-8c98-5a2079d30520/iso-2974-2005>

Diesel engines — High-pressure fuel injection pipe end-connections with 60° female cone

1 Scope

This International Standard specifies the dimensional requirements of high-pressure pipe end-connections for diesel (compression-ignition) engine fuel injection equipment.

It is applicable to externally threaded end-connections of types 1 and 2 having a 60° female cone (see Figures 1 to 3), as well as to the pipe end assemblies of high-pressure fuel injection pipes with outside diameters of up to and including 12 mm (see Table 1).

2 Normative references

The following referenced documents are indispensable for the application of this document. For dated references, only the edition cited applies. For undated references, the latest edition of the referenced document (including any amendments) applies.

ISO 261:1998, *ISO general purpose metric screw threads — General plan*

ISO 3508:1976, *Thread run-outs for fasteners with thread in accordance with ISO 261 and ISO 262*

3 Requirements

3.1 Dimensions and tolerances

Figures 1 and 2 indicate the basic requirements for the end-connection at the fuel injector and fuel injection pump to allow interchangeability for high-pressure fuel injection pipe assemblies.

The 60° female cone and its relationship to the external thread of the end-connection shall meet the requirements of Figure 1. However, variations at the smaller end of the female cone as shown in Figure 3 are acceptable.

Dimensions and tolerances are given in Table 1. Unspecified details are left to the manufacturer's choice.

With reference dimension T in Figures 1 and 2, the external thread may be of either type 1 or type 2. However, it shall be possible to screw the GO-gauge for the thread up to the plane specified by dimension T for both types.

Figure 4 identifies the pipe end assembly dimensions that are important to sealing - those normally on the leading edge of the sealing face of the connection end (see also 3.2).

3.2 Materials

The specification of material and heat treatment shall be made according to the intended use.

To ensure that deformation takes place at the sealing face of the connection end, the connection end of the high-pressure injection pipe shall be softer than the female cone of the end-connection of the fuel injection pump or the fuel injector.

4 Designation

An end-connection conforming to this International Standard shall be designated by the following elements, in the order given:

- a) reference to this International Standard;
- b) the shape, in accordance with Figure 3;
- c) the tube outside diameter, in millimetres;
- d) the thread designation, in accordance with ISO 261.

EXAMPLE An end-connection of shape A, of pipe outside diameter 10 mm, with an M22 × 1,5 thread is designated:

ISO 2974 A 10 – M22 × 1,5

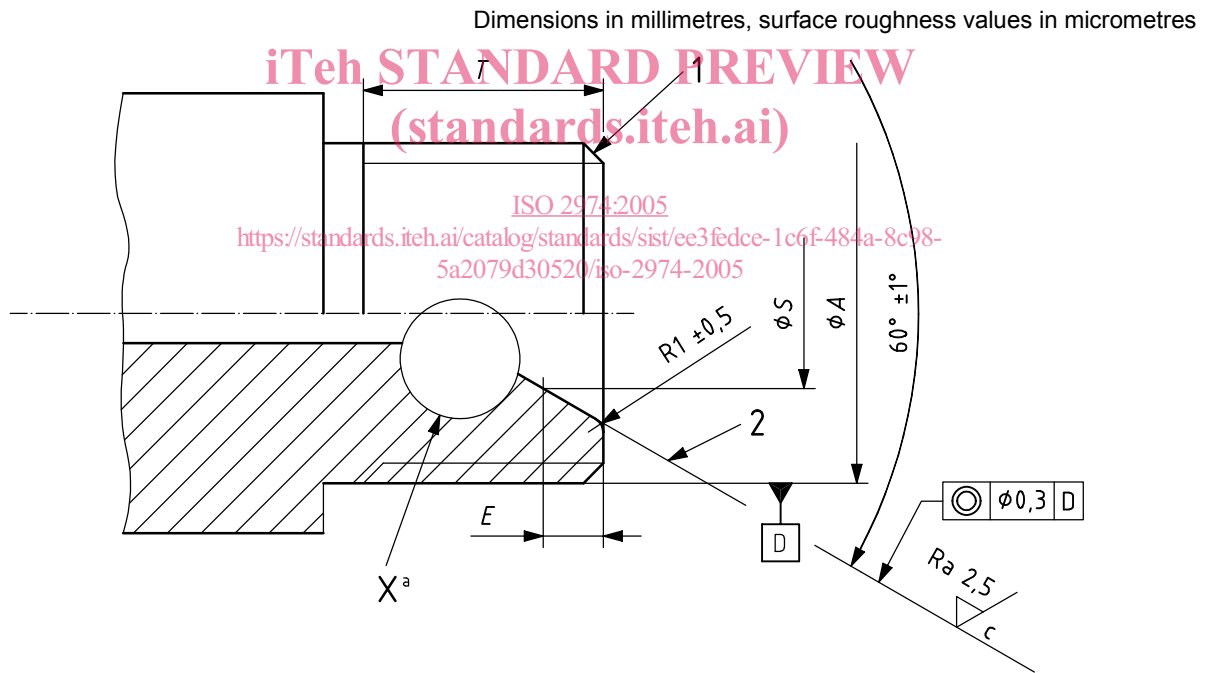

Key

- 1 chamfer to root of thread
- 2 female sealing face

NOTE See Table 1 for dimensions *A*, *E*, *S* and *T*.

^a See Figure 3.

Figure 1 — End-connection, type 1

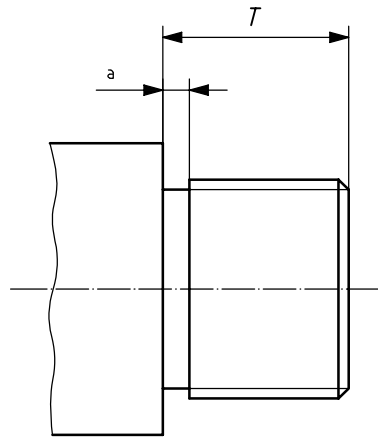

NOTE 1 All dimensions and specifications other than the undercut ^a are the same as for type 1.

NOTE 2 See Table 1 for dimension *T*.

^a Undercut in accordance with ISO 3508.

Figure 2 — End-connection, type 2

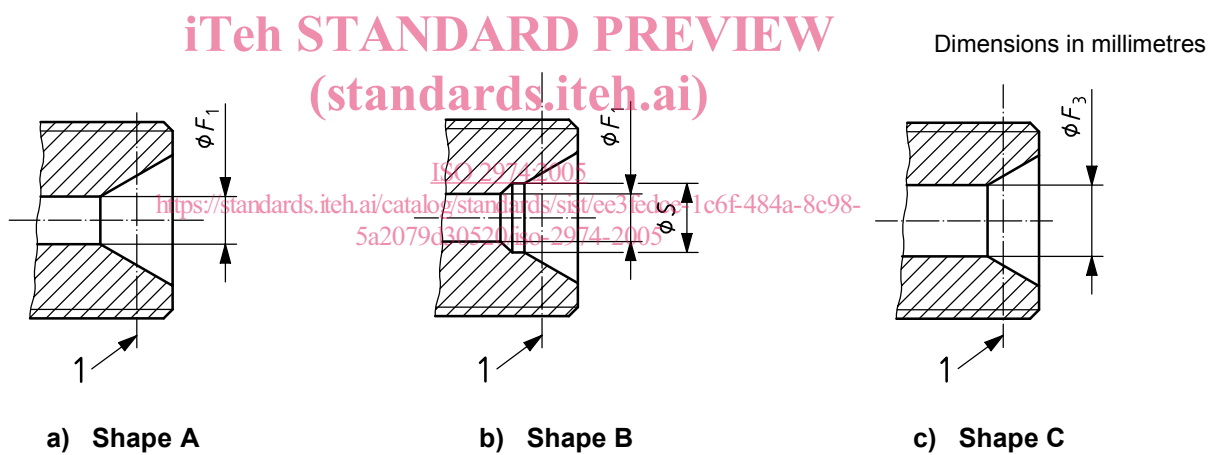

Key

1 reference diameter plane

NOTE See Table 1 for dimensions *S*, *F*₁ and *F*₃.

Figure 3 — Shapes of detail X (Figure 1) on female cones, types 1 and 2

Dimensions in millimetres

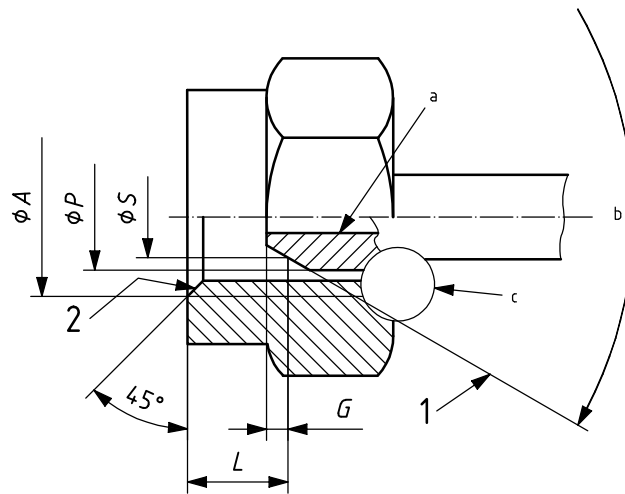

Key

- 1 connection end sealing face
- 2 chamfer to root of threads

NOTE See Table 1 for dimensions *A*, *G*, *L*, *P* and *S*.

- a The connection end bore entrance configuration shall be so chosen that, after final assembly, the pipe inside diameter is not reduced.
- b $58^\circ \pm 1^\circ$ included angle (other shapes by agreement).
- c Design of the shoulder of connection end and the connector nut shall be agreed between customer and manufacturer.

Figure 4 — Pipe end assembly

<https://standards.iteh.ai/catalog/standards/sist/ee3fedce-1c6f-484a-8c98-5a2079d30520/iso-2974-2005>

Table 1

Dimensions in millimetres

Tube outside diameter	Thread ^a <i>A</i>	Reference diameter <i>S</i>	<i>F</i> ₁ ^b ±0,1	<i>F</i> ₃ ^b max.	<i>E</i> +0,3 0	<i>P</i> ±0,5	<i>G</i> +0,5 0	<i>L</i> max.	<i>T</i> min.
4,5	M10 × 1,25 M12 × 1,5	5	1,12 to 2,24	—	0,8	7	0,5	7	10
6	M12 × 1,5 M14 × 1,5	6,5	1,5 to 3	6,1	0,8	9	0,8	8	11
7	M14 × 1,5	6,5 ^c or 7,5	1,5 to 3	6,1	0,8	9 ^c or 10,5	0,8	8	11
8	M16 × 1,5 M18 × 1,5 M22 × 1,5	8,5	2 to 4	7,3	2,6	11,5	0,9	11	16,5
10	M20 × 1,5 M22 × 1,5 M24 × 1,5	10,5	2,5 to 5	9,3	2,6	13,5	0,9	12,5	18
12	M22 × 1,5 M26 × 1,5	12,5	3 to 5	10,3	2,6	15,5	1,8	15,5	21

^a Tolerance classes of threads: 6g for external threaded end-connection; 6H for connector nuts.
^b Dimension *F*₁ shall be adapted to the inside diameter of the pipe for the sake of optimum flow conditions. If required, for instance for edge filters, application of dimension *F*₃ is allowed.
^c In case outer diameter *P* of 9 is used with reference diameter *S* of 6,5 mm, then a connector collar shall be applied for strengthening.

Bibliography

- [1] ISO 7876-4, *Fuel injection equipment — Vocabulary — Part 4: High-pressure pipes and end-connections*

iTeh STANDARD PREVIEW
(standards.iteh.ai)

[ISO 2974:2005](https://standards.iteh.ai/catalog/standards/sist/ee3fedce-1c6f-484a-8c98-5a2079d30520/iso-2974-2005)

<https://standards.iteh.ai/catalog/standards/sist/ee3fedce-1c6f-484a-8c98-5a2079d30520/iso-2974-2005>