



**SLOVENSKI STANDARD**  
**kSIST FprEN 14399-6:2014**

**01-oktober-2014**

---

**Visokotrdozne strukturne vijačne zveze za prednapetje - 6. del: Ploščate posnete podložke**

High-strength structural bolting assemblies for preloading - Part 6: Plain chamfered washers

Hochfeste vorspannbare Garnituren für Schraubverbindungen im Metallbau - Teil 6: Flache Scheiben mit Fase

Boulonnerie de construction métallique à haute résistance apte à la précontrainte - Partie 6: Rondelles plates chanfreinées

**Ta slovenski standard je istoveten z: FprEN 14399-6**

---

**ICS:**

21.060.30 Podložke, varovalni elementi Washers, locking elements

**kSIST FprEN 14399-6:2014**

**en,fr,de**



EUROPEAN STANDARD  
NORME EUROPÉENNE  
EUROPÄISCHE NORM

**FINAL DRAFT**  
**FprEN 14399-6**

July 2014

ICS 21.060.30

Will supersede EN 14399-6:2005

English Version

## High-strength structural bolting assemblies for preloading - Part 6: Plain chamfered washers

Boulonnerie de construction métallique à haute résistance  
apte à la précontrainte - Partie 6 : Rondelles plates  
chanfreinées

Hochfeste vorspannbare Garnituren für  
Schraubverbindungen im Metallbau - Teil 6: Flache  
Scheiben mit Fase

This draft European Standard is submitted to CEN members for formal vote. It has been drawn up by the Technical Committee CEN/TC 185.

If this draft becomes a European Standard, CEN members are bound to comply with the CEN/CENELEC Internal Regulations which stipulate the conditions for giving this European Standard the status of a national standard without any alteration.

This draft European Standard was established by CEN in three official versions (English, French, German). A version in any other language made by translation under the responsibility of a CEN member into its own language and notified to the CEN-CENELEC Management Centre has the same status as the official versions.

CEN members are the national standards bodies of Austria, Belgium, Bulgaria, Croatia, Cyprus, Czech Republic, Denmark, Estonia, Finland, Former Yugoslav Republic of Macedonia, France, Germany, Greece, Hungary, Iceland, Ireland, Italy, Latvia, Lithuania, Luxembourg, Malta, Netherlands, Norway, Poland, Portugal, Romania, Slovakia, Slovenia, Spain, Sweden, Switzerland, Turkey and United Kingdom.

Recipients of this draft are invited to submit, with their comments, notification of any relevant patent rights of which they are aware and to provide supporting documentation.

**Warning** : This document is not a European Standard. It is distributed for review and comments. It is subject to change without notice and shall not be referred to as a European Standard.



EUROPEAN COMMITTEE FOR STANDARDIZATION  
COMITÉ EUROPÉEN DE NORMALISATION  
EUROPÄISCHES KOMITEE FÜR NORMUNG

**CEN-CENELEC Management Centre: Avenue Marnix 17, B-1000 Brussels**

<b>Contents</b>		Page
Foreword.....		3
Introduction .....		4
1	Scope .....	6
2	Normative references .....	6
3	Dimensions.....	6
4	Specification and reference standards .....	7
5	Designation .....	8
6	Marking .....	8
Bibliography.....		9

## Foreword

This document (FprEN 14399-6:2014) has been prepared by Technical Committee CEN/TC 185 “Fasteners”, the secretariat of which is held by DIN.

This document is currently submitted to the Formal Vote.

This document will supersede EN 14399-6:2005.

EN 14399 consists of the following parts, under the general title *High-strength structural bolting assemblies for preloading*:

- *Part 1: General requirements;*
- *Part 2: Suitability for preloading;*
- *Part 3: System HR — Hexagon bolt and nut assemblies;*
- *Part 4: System HV — Hexagon bolt and nut assemblies;*
- *Part 5: Plain washers;*
- *Part 6: Plain chamfered washers;*
- *Part 7: System HR — Countersunk head bolt and nut assemblies;*
- *Part 8: System HV — Hexagon fit bolt and nut assemblies;*
- *Part 9: System HR or HV — Direct tension indicators for bolt and nut assemblies;*
- *Part 10: System HRC — Bolt and nut assemblies with calibrated preload.*

## Introduction

This document on structural bolting reflects the situation in Europe where two technical solutions exist to achieve the necessary ductility of bolt/nut/washer(s) assemblies. These solutions consist of two different systems (HR and HV) of bolt/nut/washer assemblies, see Table 1. Both systems are well proven and it is the responsibility of the experts using structural bolting whether they use the one or the other system.

It is, however, important for the performance of the assembly to avoid mixing up the components of both systems. Therefore, bolts and nuts for both systems are standardized in one single part of this European Standard each and the marking of the components of the same system is uniform.

Preloaded bolted assemblies are very sensitive to differences in manufacture and lubrication. Therefore it is important that the bolting assemblies are supplied by one manufacturer who is always responsible for the functionality of the bolting assemblies.

For the same reason it is important that coating of the bolting assemblies is under the control of one manufacturer.

Beside the mechanical properties of the components, the functionality of the bolting assemblies requires that the specified preload can be achieved if the bolting assemblies are tightened with a suitable procedure. For this purpose a test method for the suitability of the bolting assemblies for preloading was created, which will demonstrate whether the functionality of the bolting assemblies is fulfilled.

It should be pointed out that compared to ISO 272 the widths across flats (large series) for M12 and M20 have been changed to 22 mm and 32 mm respectively. These changes are justified by the following reasons.

Under the specific conditions of structural bolting, the compressive stresses under the bolt head or nut for the sizes M12 may become too large with the width across flats of 21 mm, especially if the washer is fitted eccentrically to the bolt axis.

For the size M20, the width across flats of 34 mm is very difficult to be produced. The change to 32 mm is primarily motivated by economics but it should also be pointed out that the width across flats of 32 mm was common practice in Europe.

Table 1 — Composition of high-strength structural bolting assemblies and component marking

Type of bolting assembly		System HR				System HV		System HRC	
General requirements		EN 14399-1							
Suitability for preloading		EN 14399-2 and, if any, additional testing specified in the product standard							
Bolt and nut		EN 14399-3		EN 14399-7		EN 14399-4	EN 14399-8	EN 14399-10	
Marking	Bolt	HR8.8	HR10.9	HR8.8	HR10.9	HV10.9	HVP10.9	HRC10.9	
	Nut	HR8 or HR10	HR10	HR8 or HR10	HR10	HV10	HV10	HR10	HRD10
Washer(s)		EN 14399-5 <sup>a</sup> or EN 14399-6				EN 14399-6			EN 14399-5 <sup>a</sup> or EN 14399-6
Marking		H or HR <sup>b</sup>				H or HV <sup>b</sup>		H or HR <sup>b</sup>	H or HR <sup>b</sup> or HD <sup>c</sup>
Direct tension indicator and nut face washer or bolt face washer, if any		EN 14399-9						Not applicable	
Marking	Direct tension indicator	H8	H10	H8	H10	H10			
	Nut face washer	HN				HN			
	Bolt face washer	HB		Not applicable		HB			
<sup>a</sup> EN 14399-5 can only be used under the nut. <sup>b</sup> At the choice of the manufacturer. <sup>c</sup> Mandatory mark for washers with enlarged outer diameter according to EN 14399-5 only.									

## FprEN 14399-6:2014 (E)

### 1 Scope

This European Standard specifies, together with EN 14399-1 and EN 14399-2, hardened and tempered chamfered plain washers with chamfer intended for bolting assemblies with large series hexagon high-strength structural bolts and nuts with thread sizes from M12 to M36 inclusive.

Washers according to this standard are not intended to be used in direct contact with oversized or slotted holes.

NOTE Attention is drawn to the importance of ensuring that the washers are correctly used if satisfactory results are to be obtained. For recommendations concerning proper application, reference to EN 1090-2 is made.

### 2 Normative references

The following documents, in whole or in part, are normatively referenced in this document and are indispensable for its application. For dated references, only the edition cited applies. For undated references, the latest edition of the referenced document (including any amendments) applies.

EN 14399-1, *High-strength structural bolting assemblies for preloading — Part 1: General requirements*

EN 14399-2, *High-strength structural bolting assemblies for preloading — Part 2: Suitability for preloading*

EN ISO 3269, *Fasteners — Acceptance inspection (ISO 3269)*

EN ISO 4759-3, *Tolerances for fasteners — Part 3: Plain washers for bolts, screws and nuts — Products grades A and C (ISO 4759-3)*

EN ISO 10684, *Fasteners — Hot dip galvanized coatings (ISO 10684)*

### 3 Dimensions

See Figure 1 and Table 2.

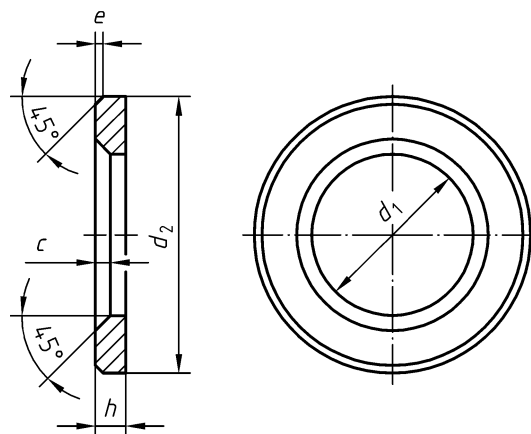

Figure 1 — Dimensions

For coated washers the above dimensions apply prior to coating.