



# SLOVENSKI STANDARD

## SIST EN 14399-6:2015

01-maj-2015

Nadomešča:

SIST EN 14399-6:2005

SIST EN 14399-6:2005/AC:2006

---

**Visokotrdnostne strukturne vijajčne zveze za prednapetje - 6. del: Ploščate posnete podložke**

High-strength structural bolting assemblies for preloading - Part 6: Plain chamfered washers

**iTeh STANDARD PREVIEW**

Hochfeste vorspannbare Garnituren für Schraubverbindungen im Metallbau - Teil 6: Flache Scheiben mit Fase

[SIST EN 14399-6:2015](https://standards.iteh.ai/catalog/standards/sist/9e4d7fd4-4319-4b17-90b9-a9f573ec0fe1/sist-en-14399-6-2015)

Boulonnerie de construction métallique à haute résistance apte à la précontrainte - Partie 6: Rondelles plates chanfreinées

**Ta slovenski standard je istoveten z: EN 14399-6:2015**

---

**ICS:**

21.060.30 Podložke, varovalni elementi Washers, locking elements

**SIST EN 14399-6:2015**

**en,fr,de**

**iTeh STANDARD PREVIEW**  
**(standards.iteh.ai)**

SIST EN 14399-6:2015

<https://standards.iteh.ai/catalog/standards/sist/9a4dfbd4-4319-4b17-90b9-a9f573ec0fe1/sist-en-14399-6-2015>

EUROPEAN STANDARD

EN 14399-6

NORME EUROPÉENNE

EUROPÄISCHE NORM

February 2015

ICS 21.060.30

Supersedes EN 14399-6:2005

English Version

## High-strength structural bolting assemblies for preloading - Part 6: Plain chamfered washers

Boulonnerie de construction métallique à haute résistance  
apte à la précontrainte - Partie 6 : Rondelles plates  
chanfreinées

Hochfeste vorspannbare Garnituren für  
Schraubverbindungen im Metallbau - Teil 6: Flache  
Scheiben mit Fase

This European Standard was approved by CEN on 18 October 2014.

CEN members are bound to comply with the CEN/CENELEC Internal Regulations which stipulate the conditions for giving this European Standard the status of a national standard without any alteration. Up-to-date lists and bibliographical references concerning such national standards may be obtained on application to the CEN-CENELEC Management Centre or to any CEN member.

This European Standard exists in three official versions (English, French, German). A version in any other language made by translation under the responsibility of a CEN member into its own language and notified to the CEN-CENELEC Management Centre has the same status as the official versions.

CEN members are the national standards bodies of Austria, Belgium, Bulgaria, Croatia, Cyprus, Czech Republic, Denmark, Estonia, Finland, Former Yugoslav Republic of Macedonia, France, Germany, Greece, Hungary, Iceland, Ireland, Italy, Latvia, Lithuania, Luxembourg, Malta, Netherlands, Norway, Poland, Portugal, Romania, Slovakia, Slovenia, Spain, Sweden, Switzerland, Turkey and United Kingdom.

[SIST EN 14399-6:2015](https://standards.iteh.ai/catalog/standards/sist/9a4dfbd4-4319-4b17-90b9-a9f573ec0fe1/sist-en-14399-6-2015)

<https://standards.iteh.ai/catalog/standards/sist/9a4dfbd4-4319-4b17-90b9-a9f573ec0fe1/sist-en-14399-6-2015>



EUROPEAN COMMITTEE FOR STANDARDIZATION  
COMITÉ EUROPÉEN DE NORMALISATION  
EUROPÄISCHES KOMITEE FÜR NORMUNG

CEN-CENELEC Management Centre: Avenue Marnix 17, B-1000 Brussels

<b>Contents</b>		Page
Foreword.....		3
Introduction .....		4
1	Scope .....	6
2	Normative references .....	6
3	Dimensions.....	6
4	Specification and reference standards .....	7
5	Designation .....	8
6	Marking .....	8
Bibliography.....		9

**iTeh STANDARD PREVIEW**  
**(standards.iteh.ai)**

[SIST EN 14399-6:2015](https://standards.iteh.ai/catalog/standards/sist/9a4dfbd4-4319-4b17-90b9-a9f573ec0fe1/sist-en-14399-6-2015)

<https://standards.iteh.ai/catalog/standards/sist/9a4dfbd4-4319-4b17-90b9-a9f573ec0fe1/sist-en-14399-6-2015>

## Foreword

This document (EN 14399-6:2015) has been prepared by Technical Committee CEN/TC 185 "Fasteners", the secretariat of which is held by DIN.

This European Standard shall be given the status of a national standard, either by publication of an identical text or by endorsement, at the latest by August 2015 and conflicting national standards shall be withdrawn at the latest by November 2016.

Attention is drawn to the possibility that some of the elements of this document may be the subject of patent rights. CEN [and/or CENELEC] shall not be held responsible for identifying any or all such patent rights.

This document supersedes EN 14399-6:2005.

In comparison with EN 14399-6:2005, the following modifications have been made:

- Table 1 containing the overview of the composition of bolting assemblies and component marking has been added;
- specifications for the marking of washers have been revised.

EN 14399 consists of the following parts, under the general title *High-strength structural bolting assemblies for preloading*:

- iTeh STANDARD PREVIEW**
- *Part 1: General requirements;* ([standards.iteh.ai](https://standards.iteh.ai/))
  - *Part 2: Suitability for preloading;*
  - *Part 3: System HR — Hexagon bolt and nut assemblies;* [SIST EN 14399-6:2015](https://standards.iteh.ai/catalog/standards/sist/9a4dfbd4-4319-4b17-90b9-a9f573ec0fe1/sist-en-14399-6-2015)
  - *Part 4: System HV — Hexagon bolt and nut assemblies;*
  - *Part 5: Plain washers;*
  - *Part 6: Plain chamfered washers;*
  - *Part 7: System HR — Countersunk head bolt and nut assemblies;*
  - *Part 8: System HV — Hexagon fit bolt and nut assemblies;*
  - *Part 9: System HR or HV — Direct tension indicators for bolt and nut assemblies;*
  - *Part 10: System HRC — Bolt and nut assemblies with calibrated preload.*

According to the CEN-CENELEC Internal Regulations, the national standards organizations of the following countries are bound to implement this European Standard: Austria, Belgium, Bulgaria, Croatia, Cyprus, Czech Republic, Denmark, Estonia, Finland, Former Yugoslav Republic of Macedonia, France, Germany, Greece, Hungary, Iceland, Ireland, Italy, Latvia, Lithuania, Luxembourg, Malta, Netherlands, Norway, Poland, Portugal, Romania, Slovakia, Slovenia, Spain, Sweden, Switzerland, Turkey and the United Kingdom.

## Introduction

This document on structural bolting reflects the situation in Europe where two technical solutions exist to achieve the necessary ductility of bolt/nut/washer(s) assemblies. These solutions consist of two different systems (HR and HV) of bolt/nut/washer assemblies, see Table 1. Both systems are well proven and it is the responsibility of the experts using structural bolting whether they use the one or the other system.

It is, however, important for the performance of the assembly to avoid mixing up the components of both systems. Therefore, bolts and nuts for both systems are standardized in one single part of this European Standard each and the marking of the components of the same system is uniform.

Preloaded bolted assemblies are very sensitive to differences in manufacture and lubrication. Therefore, it is important that the bolting assemblies are supplied by one manufacturer who is always responsible for the functionality of the bolting assemblies.

For the same reason it is important that coating of the bolting assemblies is under the control of one manufacturer.

Beside the mechanical properties of the components, the functionality of the bolting assemblies requires that the specified preload can be achieved if the bolting assemblies are tightened with a suitable procedure. For this purpose a test method for the suitability of the bolting assemblies for preloading was created, which will demonstrate whether the functionality of the bolting assemblies is fulfilled.

It should be pointed out that compared to ISO 272 the widths across flats (large series) for M12 and M20 have been changed to 22 mm and 32 mm respectively. These changes are justified by the following reasons.

Under the specific conditions of structural bolting, the compressive stresses under the bolt head or nut for the sizes M12 may become too large with the width across flats of 21 mm, especially if the washer is fitted eccentrically to the bolt axis.

For the size M20, the width across flats of 34 mm is very difficult to be produced. The change to 32 mm is primarily motivated by economics but it should also be pointed out that the width across flats of 32 mm was common practice in Europe.

Table 1 — Composition of high-strength structural bolting assemblies and component marking

Type of bolting assembly		System HR				System HV		System HRC	
General requirements		EN 14399-1							
Suitability for preloading		EN 14399-2 and, if any, additional testing specified in the product standard							
Bolt and nut		EN 14399-3		EN 14399-7		EN 14399-4	EN 14399-8	EN 14399-10	
Marking	Bolt	HR8.8	HR10.9	HR8.8	HR10.9	HV10.9	HVP10.9	HRC10.9	
	Nut	HR8 or HR10	HR10	HR8 or HR10	HR10	HV10	HV10	HR10	HRD10
Washer(s)		EN 14399-5 <sup>a</sup> or EN 14399-6				EN 14399-6		EN 14399-5 <sup>a</sup> or EN 14399-6	
Marking		H or HR <sup>b</sup>				H or HV <sup>b</sup>		H or HR <sup>b</sup>	H or HR <sup>b</sup> or HD <sup>c</sup>
Direct tension indicator and nut face washer or bolt face washer, if any		EN 14399-9 <a href="https://standards.iteh.ai/catalog/standards/sist/9a4dfbd4-4319-4b17-90b9-a9f573ec0fe1/sist-en-14399-6-2015">https://standards.iteh.ai/catalog/standards/sist/9a4dfbd4-4319-4b17-90b9-a9f573ec0fe1/sist-en-14399-6-2015</a>						Not applicable	
Marking	Direct tension indicator	H8	H10	H8	H10	H10			
	Nut face washer	HN				HN			
	Bolt face washer	HB		Not applicable		HB			
<sup>a</sup> EN 14399-5 can only be used under the nut. <sup>b</sup> At the choice of the manufacturer. <sup>c</sup> Mandatory mark for washers with enlarged outer diameter according to EN 14399-5 only.									

## EN 14399-6:2015 (E)

## 1 Scope

This European Standard specifies, together with EN 14399-1 and EN 14399-2, hardened and tempered chamfered plain washers with chamfer intended for bolting assemblies with large series hexagon high-strength structural bolts and nuts with thread sizes from M12 to M36 inclusive.

Washers according to this standard are not intended to be used in direct contact with oversized or slotted holes.

NOTE Attention is drawn to the importance of ensuring that the washers are correctly used if satisfactory results are to be obtained. For recommendations concerning proper application, reference to EN 1090-2 is made.

## 2 Normative references

The following documents, in whole or in part, are normatively referenced in this document and are indispensable for its application. For dated references, only the edition cited applies. For undated references, the latest edition of the referenced document (including any amendments) applies.

EN 14399-1, *High-strength structural bolting assemblies for preloading - Part 1: General requirements*

EN 14399-2, *High-strength structural bolting assemblies for preloading - Part 2: Suitability for preloading*

EN ISO 3269, *Fasteners - Acceptance inspection (ISO 3269)*

EN ISO 4759-3, *Tolerances for fasteners - Part 3: Plain washers for bolts, screws and nuts - Products grades A and C (ISO 4759-3)*

EN ISO 10684, *Fasteners - Hot dip galvanized coatings (ISO 10684)*

<https://standards.iteh.ai/catalog/standards/sist/9a4dfbd4-4319-4b17-90b9-a9f573ec0fe1/sist-en-14399-6-2015>

## 3 Dimensions

See Figure 1 and Table 2.

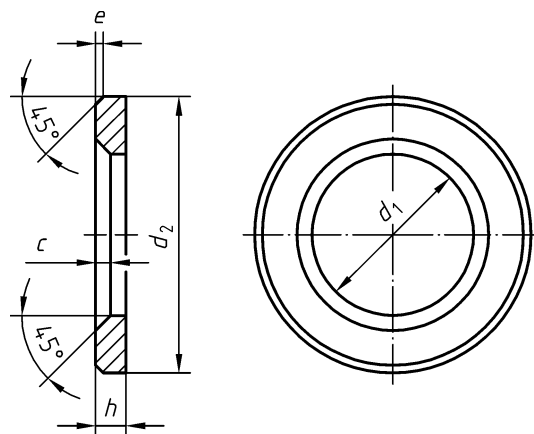

Figure 1 — Dimensions

For coated washers the above dimensions apply prior to coating.



Table 2 — Dimensions

Dimensions in millimetres

Nominal size		12	(14) <sup>a</sup>	16	(18) <sup>a</sup>	20	22	24	27	30	36
<i>d</i>	(nominal thread diameter of associated bolts)										
<i>d</i> <sub>1</sub>	min.	13	15	17	19	21	23	25	28	31	37
	max.	13,27	15,27	17,27	19,33	21,33	23,33	25,33	28,52	31,62	37,62
<i>d</i> <sub>2</sub>	min.	23,48	27,48	29,48	33,38	36,38	38,38	43,38	49,00	54,80	64,80
	max.	24	28	30	34	37	39	44	50	56	66
<i>h</i>	nom.	3	3	4	4	4	4	4	5	5	6
	min.	2,7	2,7	3,7	3,7	3,7	3,7	3,7	4,4	4,4	5,4
	max.	3,3	3,3	4,3	4,3	4,3	4,3	4,3	5,6	5,6	6,6
<i>e</i>	nom. = min.	0,5	0,5	0,75	0,75	0,75	0,75	0,75	1	1	1,25
	max.	1,0	1,0	1,5	1,5	1,5	1,5	1,5	2,0	2,0	2,5
<i>c</i>	min.	1,6	1,6	1,6	2,0	2,0	2,0	2,0	2,5	2,5	2,5
	max.	1,9	1,9	1,9	2,5	2,5	2,5	2,5	3,0	3,0	3,0

<sup>a</sup> Sizes in brackets are non-preferred sizes.

#### 4 Specification and reference standards

Table 3 — Specifications and reference standards

Material	Steel	
<b>General requirements</b>	EN 14399-1 and EN 14399-2	
<b>Mechanical properties</b> Hardness range	300 HV to 370 HV	
<b>Tolerances</b> Product grade	A	
	European Standard	EN ISO 4759-3
<b>Finish — Coating<sup>a</sup></b> Uncoated	as processed <sup>b</sup>	
	Hot dip galvanized	EN ISO 10684
	Others	to be agreed <sup>c</sup>
<b>Workmanship</b>	Parts shall be uniform and free of irregularities or detrimental defects. No protruding burrs shall appear on the washer.	
<b>Acceptability</b>	For acceptance procedure, see EN ISO 3269.	

<sup>a</sup> Attention is drawn to the need to consider the risk of hydrogen embrittlement when selecting an appropriate surface treatment process (e.g. cleaning and coating), see the relevant coating standards.

<sup>b</sup> "As processed" means the normal finish resulting from heat treatment with a light coating of oil.

<sup>c</sup> Other coatings may be negotiated between the purchaser and the manufacturer provided they do not impair the mechanical properties or the functional characteristics. Coatings of cadmium or cadmium alloys are not permitted.