



SLOVENSKI STANDARD

SIST EN 14399-7:2018

01-oktober-2018

Nadomešča:
SIST EN 14399-7:2008

Visokotrdnostne strukturne vijačne zveze za prednapetje - 7. del: Sistem HR - Zveze vijaka z vgrezno glavo in matice

High-strength structural bolting assemblies for preloading - Part 7: System HR - Countersunk head bolt and nut assemblies

Hochfeste vorspannbare Garnituren für Schraubverbindungen im Metallbau - Teil 7: System HR - Garnituren aus Senkschrauben und Muttern

Boulonnerie de construction métallique à haute résistance apte à la précontrainte - Partie 7 : Système HR - Boulons à tête fraisée vis + écrou

Ta slovenski standard je istoveten z: EN 14399-7:2018

ICS:

21.060.10	Sorniki, vijaki, stebelni vijaki	Bolts, screws, studs
21.060.20	Matice	Nuts

SIST EN 14399-7:2018 en,fr,de

iTeh STANDARD PREVIEW
(standards.iteh.ai)

SIST EN 14399-7:2018

<https://standards.iteh.ai/catalog/standards/sist/4fd83598-ead9-48a7-9b5a-6724375cdb91/sist-en-14399-7-2018>

EUROPEAN STANDARD

EN 14399-7

NORME EUROPÉENNE

EUROPÄISCHE NORM

July 2018

ICS 21.060.01

Supersedes EN 14399-7:2007

English Version

High-strength structural bolting assemblies for preloading - Part 7: System HR - Countersunk head bolt and nut assemblies

Boulonnerie de construction métallique à haute
résistance apte à la précontrainte - Partie 7 : Système
HR - Boulons à tête fraisée (vis + écrou)

Hochfeste vorspannbare Garnituren für
Schraubverbindungen im Metallbau - Teil 7: System HR
- Garnituren aus Senkschrauben und Muttern

This European Standard was approved by CEN on 15 October 2017.

CEN members are bound to comply with the CEN/CENELEC Internal Regulations which stipulate the conditions for giving this European Standard the status of a national standard without any alteration. Up-to-date lists and bibliographical references concerning such national standards may be obtained on application to the CEN-CENELEC Management Centre or to any CEN member.

iTeh STANDARD PREVIEW

This European Standard exists in three official versions (English, French, German). A version in any other language made by translation under the responsibility of a CEN member into its own language and notified to the CEN-CENELEC Management Centre has the same status as the official versions.

CEN members are the national standards bodies of Austria, Belgium, Bulgaria, Croatia, Cyprus, Czech Republic, Denmark, Estonia, Finland, Former Yugoslav Republic of Macedonia, France, Germany, Greece, Hungary, Iceland, Ireland, Italy, Latvia, Lithuania, Luxembourg, Malta, Netherlands, Norway, Poland, Portugal, Romania, Serbia, Slovakia, Slovenia, Spain, Sweden, Switzerland, Turkey and United Kingdom.



EUROPEAN COMMITTEE FOR STANDARDIZATION
COMITÉ EUROPÉEN DE NORMALISATION
EUROPÄISCHES KOMITEE FÜR NORMUNG

CEN-CENELEC Management Centre: Rue de la Science 23, B-1040 Brussels

Contents	Page
European foreword.....	3
Introduction	4
1 Scope.....	6
2 Normative references.....	6
3 Bolts	7
3.1 Dimensions of bolts.....	7
3.2 Specification for bolts and reference standard.....	11
3.3 Marking of bolts.....	11
4 Nuts	12
4.1 Dimensions of nuts.....	12
4.2 Specification for nuts and reference standards.....	14
4.3 Proof load values of nuts	15
4.4 Decarburisation of the nut thread	15
4.5 Marking of nuts.....	16
5 Designation of the bolt/nut assemblies.....	16
6 Associated washers	16
7 Functional characteristics of the bolt/nut/washer assembly	17
7.1 General.....	17
7.2 Maximum individual value of the bolt force during fitness for purpose test ($F_{bi\ max}$)	18
7.3 Values of angle $\Delta\theta_1$.....	18
7.4 Values of angle $\Delta\theta_2$.....	19
7.5 Individual values of the k-factor (k_i), mean value of the k-factor (k_m) and coefficient of variation of the k-factor (V_k)	19
7.5.1 Individual values of the k-factor (k_i) for k-class K1	19
7.5.2 Mean value of the k-factor (k_m) and coefficient of variation of the k-factor (V_k) for k-class K2	19
Annex A (normative) Clamp lengths and grip lengths.....	21
A.1 Clamp lengths for countersunk head bolting assemblies.....	21
A.2 Grip lengths for countersunk head bolting assemblies	24
Bibliography.....	27

European foreword

This document (EN 14399-7:2018) has been prepared by Technical Committee CEN/TC 185 "Fasteners", the secretariat of which is held by BSI.

This European Standard shall be given the status of a national standard, either by publication of an identical text or by endorsement, at the latest by January 2019 and conflicting national standards shall be withdrawn at the latest by January 2019.

Attention is drawn to the possibility that some of the elements of this document may be the subject of patent rights. CEN shall not be held responsible for identifying any or all such patent rights.

This document supersedes EN 14399-7:2007.

In comparison with EN 14399-7:2007, the following modifications have been made:

- Table 1 containing the overview of the composition of bolting assemblies and component marking has been revised;
- the coefficient of variation of the k -factor, V_k , was changed from 0,10 to 0,06;
- specifications for the designation of the bolting assemblies have been revised;
- Annex A with detailed specifications on clamp lengths and grip lengths has been added.

EN 14399 consists of the following parts, under the general title *High-strength structural bolting assemblies for preloading*:

- *Part 1: General requirements* SIST EN 14399-7:2018
<https://standards.iteh.ai/catalog/standards/sist/4fd83598-ead9-48a7-9b5a-6724375cdb91/sist-en-14399-7-2018>
- *Part 2: Suitability for preloading*
- *Part 3: System HR — Hexagon bolt and nut assemblies*
- *Part 4: System HV — Hexagon bolt and nut assemblies*
- *Part 5: Plain washers*
- *Part 6: Plain chamfered washers*
- *Part 7: System HR — Countersunk head bolt and nut assemblies*
- *Part 8: System HV — Hexagon fit bolt and nut assemblies*
- *Part 9: System HR or HV — Direct tension indicators for bolt and nut assemblies*
- *Part 10: System HRC — Bolt and nut assemblies with calibrated preload*

According to the CEN-CENELEC Internal Regulations, the national standards organizations of the following countries are bound to implement this European Standard: Austria, Belgium, Bulgaria, Croatia, Cyprus, Czech Republic, Denmark, Estonia, Finland, Former Yugoslav Republic of Macedonia, France, Germany, Greece, Hungary, Iceland, Ireland, Italy, Latvia, Lithuania, Luxembourg, Malta, Netherlands, Norway, Poland, Portugal, Romania, Serbia, Slovakia, Slovenia, Spain, Sweden, Switzerland, Turkey and the United Kingdom.

EN 14399-7:2018 (E)**Introduction**

This document on structural bolting reflects the situation in Europe where two technical solutions exist to achieve the necessary ductility of bolt/nut/washer(s) assemblies. These solutions consist of two different types (HR and HV) of bolt/nut/washer assemblies, see Table 1. Both types are well proven and it is the responsibility of the experts using structural bolting whether they use the one or the other type.

It is, however, important for the performance of the assembly to avoid mixing up the components of both types. Therefore, bolts and nuts for both types are standardized in one single part of this draft European Standard each and the marking of the components of the bolting assemblies is uniform.

Preloaded bolted assemblies are very sensitive to differences in manufacture and lubrication. Therefore, it is important that the bolting assemblies are supplied by one manufacturer, who is always responsible for the functionality of the bolting assemblies as supplied.

For the same reason it is important that the coating of the bolting assemblies is under the control of one manufacturer.

Beside the mechanical properties of the components, the functionality of the bolting assemblies requires that the specified preload can be achieved if the bolting assemblies are tightened with a suitable procedure. For this purpose, a test method for the suitability of the bolting assemblies for preloading was created, which will demonstrate whether the functionality of the bolting assemblies is fulfilled.

iTeh STANDARD PREVIEW
(standards.iteh.ai)

SIST EN 14399-7:2018

<https://standards.iteh.ai/catalog/standards/sist/4fd83598-ead9-48a7-9b5a-6724375cdb91/sist-en-14399-7-2018>

Table 1 — Composition of high-strength structural bolting assemblies and component marking

Type of bolting assembly		System HR				System HV		System HRC	
General requirements		EN 14399-1							
Suitability for preloading		EN 14399-2 and, if any, additional testing specified in the product standard							
Bolt and nut		EN 14399-3		EN 14399-7		EN 14399-4	EN 14399-8	EN 14399-10	
Marking	Bolt	HR8.8	HR10.9	HR8.8	HR10.9	HV10.9	HVP10.9	HRC10.9	
	Nut	HR8 or HR10	HR10	HR8 or HR10	HR10	HV10	HV10	HR10	HRD10
Washer(s)		EN 14399-5 ^a or EN 14399-6				EN 14399-6		EN 14399-5 ^a or EN 14399-6	
Marking		H or HR ^b				H or HV ^b		H or HR ^b	H or HR ^b or HD ^c
Direct tension indicator and nut face washer or bolt face washer, if any		EN 14399-9							
Marking	Direct tension indicator	H8	H10	H8	H10	H10			
	Nut face washer	HN				HN			
	bolt face washer	HB		Not applicable		HB			
^a EN 14399-5 can only be used under the nut. ^b At the choice of the manufacturer. ^c Mandatory mark for washers with enlarged outer diameter according to EN 14399-5 only.									

EN 14399-7:2018 (E)**1 Scope**

This European Standard specifies, together with EN 14399-1 and EN 14399-2, the requirements for assemblies of high-strength structural countersunk bolts and nuts of system HR suitable for preloaded joints with thread sizes M12 to M36 and property classes 8.8/8 or 8.8/10 and 10.9/10.

Bolting assemblies in accordance with this document have been designed to allow preloading of at least $0,7 f_{ub} \times A_s$ ¹⁾ according to EN 1993-1-8 (Eurocode 3) and to obtain ductility predominantly by plastic elongation of the bolt. For this purpose the components have the following characteristics:

- regular nut height according to style 1, see EN ISO 4032;
- thread length of the bolt according to ISO 888.

Bolting assemblies in accordance with this document include washers according to EN 14399-6 or to EN 14399-5.

NOTE Attention is drawn to the importance of ensuring that bolting assemblies are correctly used if satisfactory results are to be obtained. For recommendations concerning proper application, reference to EN 1090-2 is made.

General requirements and requirements for suitability for preloading are specified in EN 14399-2.

Clamp lengths and grip lengths for the bolting assemblies are specified in the normative Annex A.

2 Normative references

The following documents, in whole or in part, are normatively referenced in this document and are indispensable for its application. For dated references, only the edition cited applies. For undated references, the latest edition of the referenced document (including any amendments) applies.

EN 14399-1, *High-strength structural bolting assemblies for preloading - Part 1: General requirements*

EN 14399-2, *High-strength structural bolting assemblies for preloading - Part 2: Suitability for preloading*

EN 14399-5, *High-strength structural bolting assemblies for preloading - Part 5: Plain washers*

EN 14399-6, *High-strength structural bolting assemblies for preloading - Part 6: Plain chamfered washers*

EN 14399-9, *High-strength structural bolting assemblies for preloading - Part 9: System HR or HV - Direct tension indicators for bolt and nut assemblies*

EN 26157-1, *Fasteners - Surface discontinuities - Part 1: Bolts, screws and studs for general requirements (ISO 6157-1)*

EN ISO 898-1, *Mechanical properties of fasteners made of carbon steel and alloy steel - Part 1: Bolts, screws and studs with specified property classes - Coarse thread and fine pitch thread (ISO 898-1)*

EN ISO 898-2, *Mechanical properties of fasteners made of carbon steel and alloy steel - Part 2: Nuts with specified property classes - Coarse thread and fine pitch thread (ISO 898-2)*

EN ISO 3269, *Fasteners - Acceptance inspection (ISO 3269)*

EN ISO 4759-1, *Tolerances for fasteners - Part 1: Bolts, screws, studs and nuts - Product grades A, B and C (ISO 4759-1)*

1) f_{ub} is the nominal tensile strength (R_m) and A_s is the nominal stress area of the bolt.

EN ISO 6157-2, *Fasteners - Surface discontinuities - Part 2: Nuts (ISO 6157-2)*

EN ISO 10684, *Fasteners - Hot dip galvanized coatings (ISO 10684)*

ISO 261, *ISO general purpose metric screw threads - General plan*

ISO 965-2, *ISO general purpose metric screw threads - Tolerances - Part 2: Limits of sizes for general purpose external and internal screw threads - Medium quality*

ISO 965-5, *ISO general purpose metric screw threads - Tolerances - Part 5: Limits of sizes for internal screw threads to mate with hot-dip galvanized external screw threads with maximum size of tolerance position h before galvanizing*

ISO 3508, *Thread run-outs for fasteners with thread in accordance with ISO 261 and ISO 262*

3 Bolts

3.1 Dimensions of bolts

See Figure 1 and Table 2.

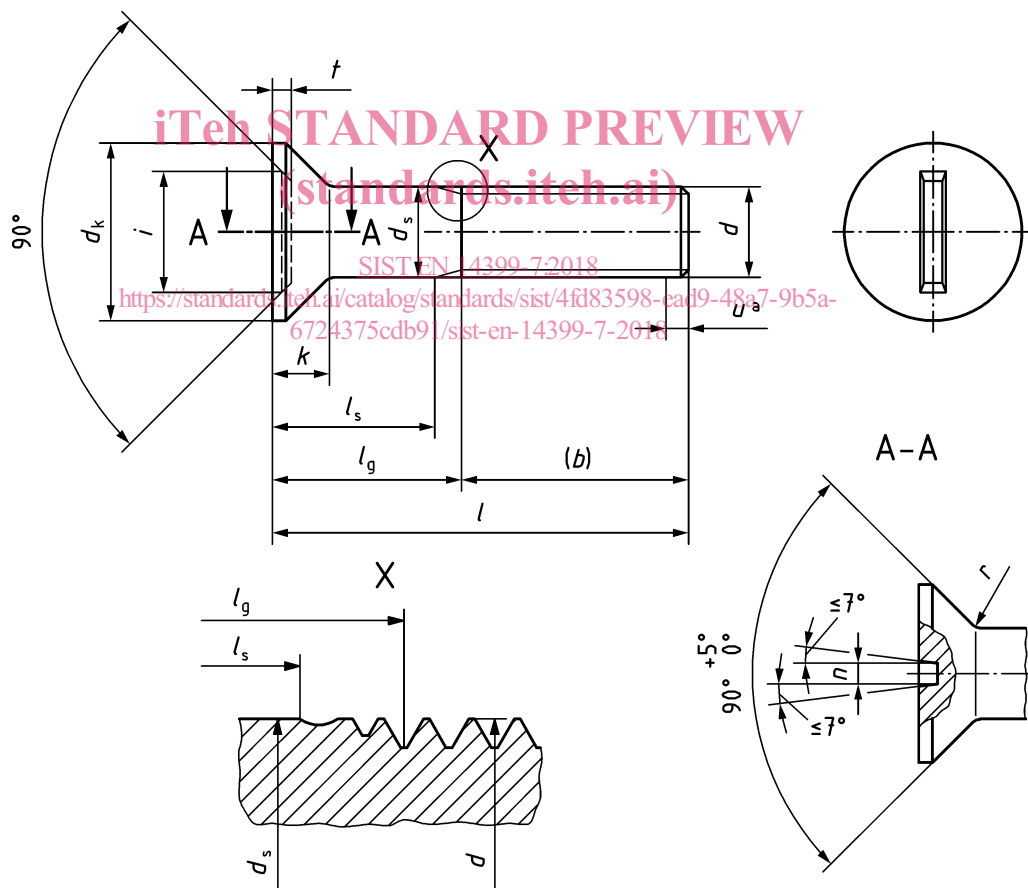

Key

^a incomplete thread $u \leq 2P$

Figure 1 — Dimensions of bolts

The difference between l_g and l_s should not be less than $1,5 P$.

For coated bolts, the dimensions apply prior to coating.

Table 2 — Dimensions of bolts

Dimensions in millimetres

Thread d		M12	(M14) ^a	M16	(M18) ^a	M20							
P^b		1,75	2	2	2,5	2,5							
b (ref.)	^c	30	34	38	42	46							
	^d	—	40	44	48	52							
	^e	—	—	—	—	65							
d_s	max.	12,70	14,70	16,70	18,70	20,84							
	min.	11,30	13,30	15,30	17,30	19,16							
d_k	max.	24,00	28,00	32,00	36,00	40,00							
	min.	23,16	27,16	31,16	35,00	39,00							
i	max.	16,5	19,5	22,5	25,5	28,5							
	min.	15,5	18,5	21,5	24,5	27,5							
k	nom.	8,0	9,0	10,0	12,0	13,0							
	max. ^h	8,75	9,75	10,75	12,90	13,90							
	min. ⁱ	7,25	8,25	9,25	11,10	12,10							
r	max.	1,6	1,6	1,6	2,0	2,0							
	min.	1,2	1,2	1,2	1,5	1,5							
n	max.	3,0	3,0	3,0	3,5	3,5							
	min.	2,5	2,5	2,5	3,0	3,0							
t	max.	4,5	4,5	4,5	5,0	5,0							
	min.	3,0	3,0	3,0	3,5	3,5							
l		https://standards.iteh.ai/catalog/standards/sist-en-14399-7-2018/6724375c91/sist-en-14399-7-2018 and https://standards.iteh.ai/catalog/standards/sist-en-14399-7-2018/6724375c91/sist-en-14399-7-2018											
		l_s	l_g	l_s	l_g	l_s	l_g	l_s	l_g	l_s	l_g	l_s	l_g
nom.	min.	max.	min.	max.	min.	max.	min.	max.	min.	max.	min.	max.	
45	43,75	46,25	—	15									
50	48,75	51,25	—	15			-	-					
55	53,50	56,50	16,25	25			—	18					
60	58,50	61,50	21,25	30	—	17	—	18					
65	63,50	66,50	26,25	35	21	31	—	18			—	23	
70	68,50	71,50	31,25	40	26	36	22	32			—	23	
75	73,50	76,50	36,25	45	31	41	27	37	—	22	—	23	
80	78,50	81,50	41,25	50	36	46	32	42	25,5	38	—	23	
85	83,25	86,75	46,25	55	41	51	37	47	30,5	43	26,5	39	
90	88,25	91,75	51,25	60	46	56	42	52	35,5	48	31,5	44	
95	93,25	96,75	56,25	65	51	61	47	57	40,5	53	36,5	49	
100	98,25	101,75	61,25	70	56	66	52	62	45,5	58	41,5	54	
110	108,25	111,75			66	76	62	72	55,5	68	51,5	64	
120	118,25	121,75			76	86	72	82	65,5	78	61,5	74	
130	128,0	132,0			80	90	76	86	69,5	82	65,5	78	
140	138,0	142,0			90	100	86	96	79,5	92	75,5	88	
150	148,0	152,0			100	110	96	106	89,5	102	85,5	98	
160	156,0	164,0			110	120	106	116	99,5	112	95,5	108	

Thread d			M22	M24	M27	M30	M36					
p^b			2,5	3	3	3,5	4					
b (ref.)	c		50	54	60	66	78					
	d		56	60	66	72	84					
	e		69	73	79	85	97					
d_s	max.		22,84	24,84	27,84	30,84	37,00					
	min.		21,16	23,16	26,16	29,16	35,00					
d_k	max.		44,0	48,0	54,0	60,0	72,0					
	min.		43,0	47,0	53,0	58,8	70,8					
i	max.		30,5	33,5	37,5	42,5	50,5					
	min.		29,5	32,5	36,5	41,5	49,5					
k	nom.		14,0	16,0	17,5	19,5	23,0					
	max. ^h		14,90	16,90	18,40	20,55	24,05					
	min.		13,10	15,10	16,60	18,45	21,95					
r	max.		2,0	2,0	2,5	2,5	2,5					
	min.		1,5	1,5	2,0	2,0	2,0					
n	max.		3,5	3,5	3,5	4,0	4,0					
	min.		3,0	3,0	3,0	3,5	3,5					
t	max.		5,0	5,0	5,0	5,5	5,5					
	min.		3,5	3,5	3,5	4,0	4,0					
l			l_s and $l_g^{f,g}$									
			l_s	l_g	l_s	l_g	l_s	l_g	l_s	l_g	l_s	l_g
nom.	min.	max.	min.	max.	min.	max.	min.	max.	min.	max.	min.	max.
65	63,50	66,50	—	24								
70	68,50	71,50	—	24								
75	73,50	76,50	—	24	—	28						
80	78,50	81,50	—	24	—	28	—	29,5				
85	83,25	86,75	—	24	—	28	—	29,5				
90	88,25	91,75	27,5	40	—	28	—	29,5	—	33,5		
95	93,25	96,75	32,5	45	—	28	—	29,5	—	33,5		
100	98,25	101,75	37,5	50	31	46	—	29,5	—	33,5		
110	108,25	111,75	47,5	60	41	56	35	50	—	33,5	—	39
120	118,25	121,75	57,5	70	51	66	45	60	36,5	54	—	39
130	128,0	132,0	61,5	74	55	70	49	64	40,5	58	—	39
140	138,0	142,0	71,5	84	65	80	59	74	50,5	68	—	39
150	148,0	152,0	81,5	94	75	90	69	84	60,5	78	46	66
160	156,0	164,0	91,5	104	85	100	79	94	70,5	88	56	76
170	166,0	174,0			95	110	89	104	80,5	98	66	86
180	176,0	184,0			105	120	99	114	90,5	108	76	96
190	186,0	194,0			115	130	109	124	100,5	118	86	106
200	196,0	204,0			125	140	119	134	110,5	128	96	116