

---

# INTERNATIONAL STANDARD



# 37

---

INTERNATIONAL ORGANIZATION FOR STANDARDIZATION • МЕЖДУНАРОДНАЯ ОРГАНИЗАЦИЯ ПО СТАНДАРТИЗАЦИИ • ORGANISATION INTERNATIONALE DE NORMALISATION

---

## Rubber, vulcanized — Determination of tensile stress-strain properties

*Caoutchouc vulcanisé — Essai de traction-allongement*

Second edition — 1977-10-01

**iTeh STANDARD PREVIEW**  
**(standards.iteh.ai)**

ISO 37:1977

<https://standards.iteh.ai/catalog/standards/sist/51c071ed-88fd-4120-9001-10864abb048e/iso-37-1977>

---

UDC 678.4/.7 : 620.17

Ref. No. ISO 37-1977 (E)

**Descriptors** : rubber, vulcanized rubber, tests, tension tests, test specimens, test equipment.

Price based on 6 pages

## FOREWORD

ISO (the International Organization for Standardization) is a worldwide federation of national standards institutes (ISO member bodies). The work of developing International Standards is carried out through ISO technical committees. Every member body interested in a subject for which a technical committee has been set up has the right to be represented on that committee. International organizations, governmental and non-governmental, in liaison with ISO, also take part in the work.

Draft International Standards adopted by the technical committees are circulated to the member bodies for approval before their acceptance as International Standards by the ISO Council.

International Standard ISO 37 was developed by Technical Committee ISO/TC 45, *Rubber and rubber products*.

This second edition was submitted directly to the ISO Council, in accordance with clause 6.12.1 of the Directives for the technical work of ISO. It cancels and replaces the first edition (i.e. ISO 37-1976), which had been approved by the member bodies of the following countries :

Australia	Hungary	Spain
Austria	India	Sweden
Brazil	Israel	Switzerland
Canada	Italy	United Kingdom
Chile	Korea, Rep. of	U.S.A.
Colombia	Morocco	U.S.S.R.
Czechoslovakia	Netherlands	Yugoslavia
France	New Zealand	
Germany	Poland	

The member body of the following country had expressed disapproval of the document on technical grounds :

Japan

# Rubber, vulcanized – Determination of tensile stress-strain properties

## iTeh STANDARD PREVIEW (standards.iteh.ai)

### 1 SCOPE AND FIELD OF APPLICATION

This International Standard specifies a method for the determination of tensile stress-strain properties of vulcanized rubbers.

### 2 PRINCIPLE

Stretching to breakage of standard test pieces, in the shape of either rings or dumb-bells, as described below, in a tension-testing machine capable of a substantially constant rate of traverse of the moving grip or pulley.

#### NOTES

1 Test pieces in the shape of rings and dumb-bells do not necessarily give the same values for the stress-strain properties. This is due mainly to the fact that in stretched rings the stress is not uniform over the cross-section. A second factor is the existence of grain, which may cause dumb-bells to give different values according as their length is parallel or perpendicular to the grain.

2 Rings give lower, sometimes much lower, tensile strength values than dumb-bells, the latter values being much nearer to the true tensile strength of the rubber. The estimation of true tensile strength from ring data involves extrapolation of the stress-strain curve.<sup>[1][2]</sup>

3 Types 2 and 3 dumb-bell test pieces and small size ring test pieces give somewhat higher values for the stress-strain properties than those obtained with type 1 dumb-bell test pieces and normal size ring test pieces, respectively.

### 3 APPARATUS

**Tensile test machine**, capable of a substantially constant rate of traverse of the moving grip or pulley of  $500 \pm 50$  mm/min for all test pieces, except for small size

ring test pieces for which it shall be  $100 \pm 10$  mm/min, in order to obtain the same rate of extension as with normal rings.

NOTE – Inertia (pendulum) type dynamometers are apt to give results which differ because of frictional and inertial effects. An inertialess (for example, electronic or optical transducer type) dynamometer gives results which are free from these effects, and is therefore to be preferred.

### 4 TEST PIECE

#### 4.1 Dimensions

The test piece shall be in the shape of either a ring or a dumb-bell, as described below.

##### 4.1.1 Ring test piece (normal size)

Rings shall be nominally of internal diameter 44,6 mm and external diameter 52,6 mm, the radial width nowhere deviating by more than  $\pm 0,2$  mm from the mean width. The thickness should be preferably  $4 \pm 0,2$  mm. In any one ring the thickness shall nowhere deviate by more than  $\pm 0,2$  mm from the mean thickness.

##### 4.1.2 Ring test piece (small size)

Rings shall be nominally of internal diameter 8 mm and of external diameter 10 mm, the radial width nowhere deviating by more than  $\pm 0,1$  mm from the mean width. The thickness should be preferably  $1 \pm 0,1$  mm.

A suitable machine for the preparation of small size ring test pieces is described in the annex, for guidance only.

4.1.3 *Dumb-bell test piece*

The shape of the test piece shall be determined by the die dimensioned as given in figure 1 and the table. There shall be three sizes of test piece as given in the table but a type 1 test piece should be used whenever practicable.

Gauge marks shall be provided and shall be not more than 25 mm apart for a type 1 test piece, not more than 20 mm apart for a type 2 test piece and not more than 10 mm apart for a type 3 test piece. They shall be equidistant from the ends of the central parallel-sided part of the test piece.

NOTE — The use of automatic extensometers is recommended, particularly when gauge marks, 10 mm apart, are used to measure the elongation.

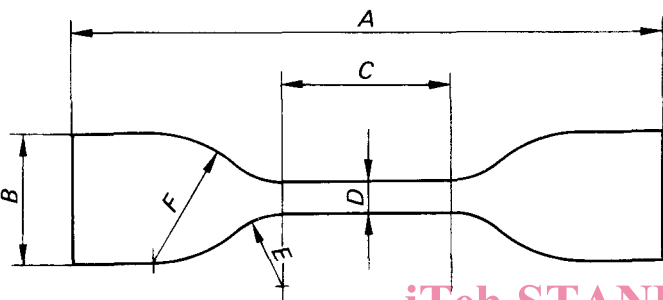

FIGURE 1 — Die

TABLE — Dimensions of test piece

Dimension	Type 1	Type 2	Type 3
	mm	mm	mm
A Overall length (minimum)	115	75	35
B Width of ends	25 ± 1	12,5 ± 1,0	6 ± 0,5
C Length of narrow parallel portion	33 ± 2	25 ± 1	12 ± 0,5
D Width of narrow parallel portion*	6,0 <sup>+0,4</sup> <sub>0</sub>	4,0 ± 0,1	2 ± 0,1
E Small radius	14 ± 1	8,0 ± 0,5	3 ± 0,1
F Large radius	25 ± 2	12,5 ± 1,0	**3 ± 0,1
Thickness	2 ± 0,2	2 ± 0,2	1 ± 0,1

\* The variation within any one die shall not exceed 0,05 mm.

\*\* Centre of circle on the centre line of dumb-bell.

4.2 Measurement

4.2.1 *Ring test pieces*

Thickness shall be measured by a micrometer gauge the foot of which exerts a pressure of 20 kPa<sup>1)</sup> on the rubber. The width shall be measured in the same way, but using a gauge with curved feet to fit the curvature of the ring.

1) 1 kPa = 1 kN/m<sup>2</sup>

• 1 min<sup>-1</sup> corresponds to 1 revolution per minute.

For precise work, the cross-section of the ring shall be calculated from its mass, density and mean circumference; for the ring specified in 4.1.1, the circumference is

$$\pi \times 48,6 \text{ mm} = 152 \text{ mm}$$

and for the small size ring specified in 4.1.2, the circumference is

$$\pi \times 9 \text{ mm} = 28,26 \text{ mm}$$

4.2.2 *Dumb-bell test pieces*

Thickness shall be measured by a gauge as specified in 4.2.1.

The width of the test piece shall be assumed to be equal to the width between the cutting edges of the narrow central part of the die. For this purpose, the width of this part of the die shall be measured to the nearest 0,05 mm.

4.3 Number

The test shall be carried out on at least three test pieces.

4.4 Conditioning

The test pieces shall be conditioned at the test temperature for not less than 16 h immediately before testing.

5 TEMPERATURE OF TEST

Tests shall be carried out at a standard laboratory temperature. The standard laboratory temperature shall be 23 ± 2 °C or 27 ± 2 °C, the same temperature being used throughout one test or series of tests intended to be comparable.

6 PROCEDURE

Fit the rings over two rotatable pulleys, 25 mm in diameter, at least one of which, preferably the moving pulley, is automatically rotated by the machine to equalize the strain in the ring while it is being stretched. (With the small size ring test piece, use rotatable pulleys of 4,5 mm diameter and a rotational frequency of from 10 to 50 min<sup>-1</sup>\*) Hold the dumb-bells at their widened ends in grips that tighten automatically as the tension increases and exert a uniform pressure across the width of the test piece.

Place the dumb-bell test piece centrally in the grip.

Means shall be provided for obtaining the following measurements without stopping the machine :

- a) the force on the test piece;
- b) the elongation of the test piece, as shown by either the distance between the gauge marks on the dumb-bell, or the distance between the pulleys in tests on rings.

## 7 EXPRESSION OF RESULTS

The tensile strength is given, in megapascals, by the formula :

$$\text{a) for rings} \quad \frac{F}{2A}$$

$$\text{b) for dumb-bells} \quad \frac{F}{A}$$

where

$F$  is the breaking force, in newtons;

$A$  is the initial cross-sectional area, in square millimetres.

The percentage elongation at break is given by the formula :

$$\text{a) for rings} \quad \frac{I - I_0}{I_0} \times 100$$

$$\text{b) for dumb-bells} \quad \frac{L - L_0}{L_0} \times 100$$

where

$I$  is the internal circumference, in millimetres, at break;

$I_0$  is the initial internal circumference, in millimetres;

$L$  is the length, in millimetres, between gauge marks at break;

$L_0$  is the initial length, in millimetres, between gauge marks.

The modulus is given, in megapascals, by the formula :

$$\text{a) for rings} \quad \frac{f}{2A}$$

$$\text{b) for dumb-bells} \quad \frac{f}{A}$$

where

$f$  is the force, in newtons, at the required elongation;

$A$  is the initial cross-sectional area, in square millimetres.

The percentage elongation at constant stress is given by the formula :

$$\text{a) for rings} \quad \frac{C - C_0}{C_0} \times 100$$

$$\text{b) for dumb-bells} \quad \frac{l - L_0}{L_0} \times 100$$

where

$C$  is the mean circumference, in millimetres, at the required stress;

$C_0$  is the initial mean circumference, in millimetres;

$l$  is the length, in millimetres, between gauge marks at the required stress;

$L_0$  is the initial length, in millimetres, between gauge marks.

For tensile strength, elongation at break, modulus or elongation at constant stress, the result reported shall be the middle value if an odd number of test pieces is used, or the average of the middle two values if an even number of test pieces is used, the various results being arranged in order of increasing value.

## 8 TEST REPORT

The test report shall include the following particulars :

- the values, determined in accordance with clause 7, for tensile strength, elongation at break, and modulus or elongation at constant stress;
- type of test piece used;
- method of determining cross-section (of rings);
- number of test pieces used;
- temperature of test;
- direction of grain (for dumb-bells).

## BIBLIOGRAPHY

- REECE, W. H., *Transactions of the Institution of the Rubber Industry*, 1935, **11**, p. 312.
- SCOTT, J. R., *Journal of Rubber Research*, 1949, **18**, p. 30.

ANNEX

**DESCRIPTION OF A SUITABLE MACHINE FOR THE PREPARATION OF SMALL SIZE RING TEST PIECE**

The rubber sheet from which a small size ring test piece is to be cut should have a minimum area of 12 mm × 12 mm and should preferably have a thickness of  $1 \pm 0,1$  mm. Such a sheet of uniform thickness may be obtained from a finished product using a slicing machine where the tool is a continuous band blade. A tolerance on the thickness to within  $\pm 0,03$  mm may be obtained with this machine.

A rotating cutting machine operating at a rotational frequency of  $400 \text{ min}^{-1}$  should be used to cut a small size

ring test piece from the rubber sheet. This machine should be equipped with a special tool (see figure 2) holding removable blades.

During the cutting operation, blades should be lubricated with soap solution. The blades should be discarded after 80 to 120 cuts.

A tool conforming to the dimensions shown in figure 3 should be used for holding the rubber sheet.

**iTeh STANDARD PREVIEW**  
**(standards.iteh.ai)**

[ISO 37:1977](https://standards.iteh.ai/catalog/standards/sist/51c071ed-88fd-4120-9001-10864abb048e/iso-37-1977)

<https://standards.iteh.ai/catalog/standards/sist/51c071ed-88fd-4120-9001-10864abb048e/iso-37-1977>

Dimensions in millimetres

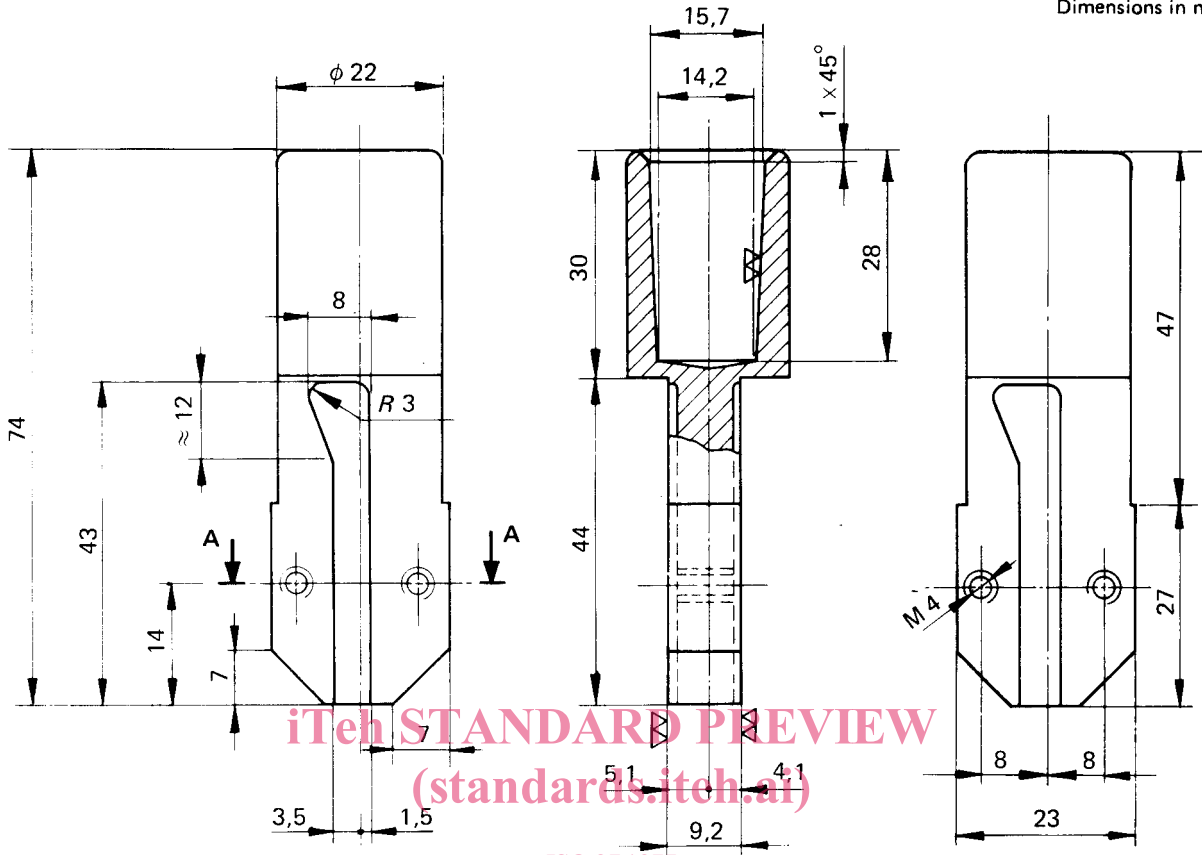

**STANDARD PREVIEW**  
 (standards.itech.ai)  
 ISO 37:1977  
 Die body  
<https://standards.itech.ai/catalog/standards/sist/51c071ed-88fd-4120-9001-10864abb048e/iso-37-1977>

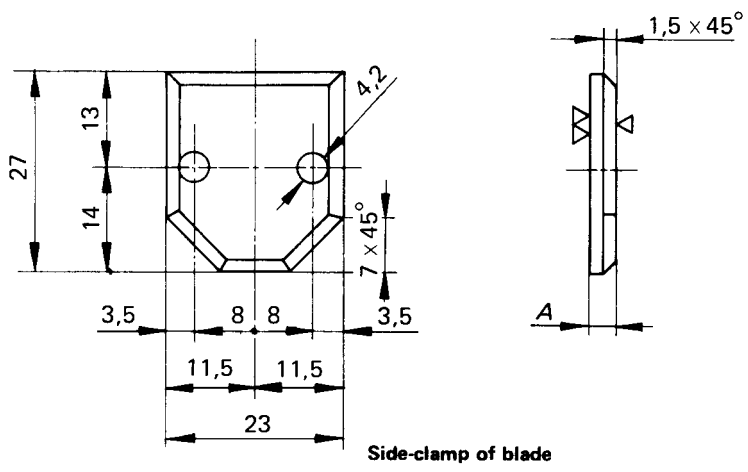
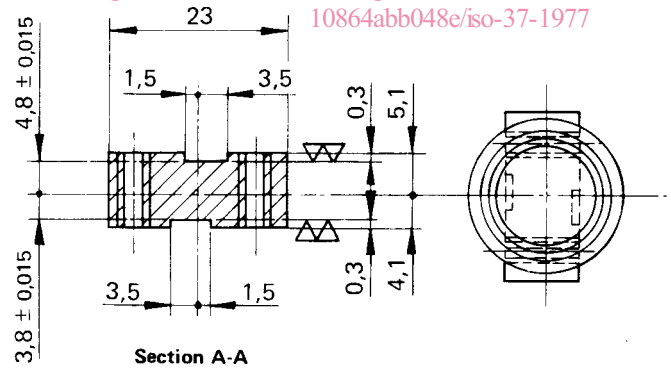

FIGURE 2 – Special tool, holding removable blades

Dimensions in millimetres

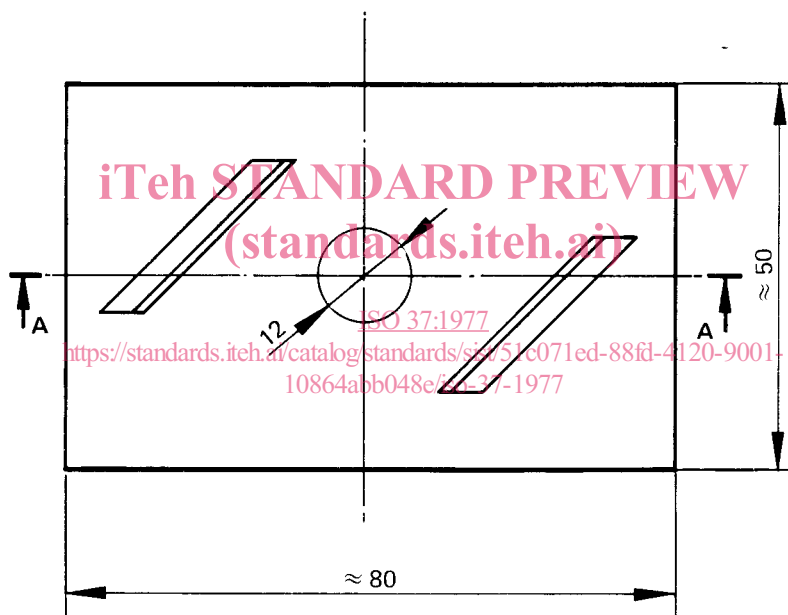
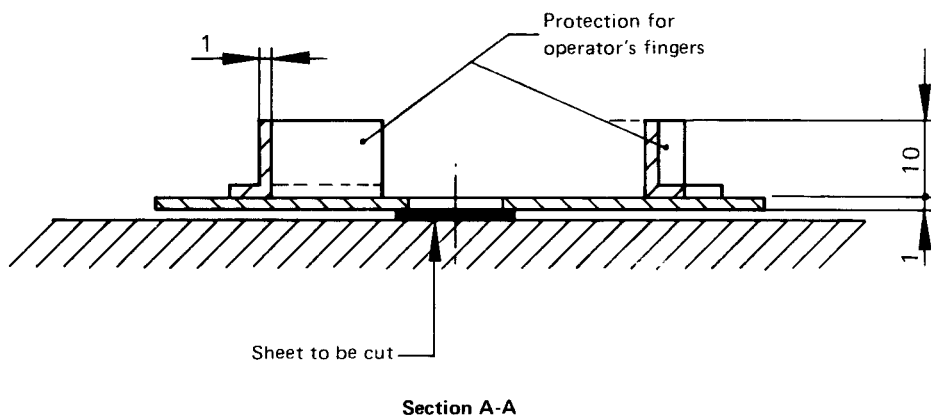

FIGURE 3 – Tool for holding rubber sheet