**Soil quality — Determination of nitrate,
nitrite and ammonium in field-moist soils
by extraction with potassium chloride
solution —**

Part 1:

Manual method

iTeh STANDARD PREVIEW
(standards.iteh.ai)

*Qualité du sol — Dosage des nitrates, des nitrites et de l'ammonium
dans les sols bruts par extraction au moyen d'une solution de chlorure
de potassium.* 1:2003

<https://standards.iteh.ai/catalog/standards/sist/af8d0916-c164-428b-b106-6207f1ce9c17/iso-ts-14256-1-2003>
Partie 1: Méthode manuelle



PDF disclaimer

This PDF file may contain embedded typefaces. In accordance with Adobe's licensing policy, this file may be printed or viewed but shall not be edited unless the typefaces which are embedded are licensed to and installed on the computer performing the editing. In downloading this file, parties accept therein the responsibility of not infringing Adobe's licensing policy. The ISO Central Secretariat accepts no liability in this area.

Adobe is a trademark of Adobe Systems Incorporated.

Details of the software products used to create this PDF file can be found in the General Info relative to the file; the PDF-creation parameters were optimized for printing. Every care has been taken to ensure that the file is suitable for use by ISO member bodies. In the unlikely event that a problem relating to it is found, please inform the Central Secretariat at the address given below.

iTeh STANDARD PREVIEW
(standards.iteh.ai)

[ISO/TS 14256-1:2003](https://standards.iteh.ai/catalog/standards/sist/af8d0916-c164-428b-b106-6207f1ce9c17/iso-ts-14256-1-2003)

<https://standards.iteh.ai/catalog/standards/sist/af8d0916-c164-428b-b106-6207f1ce9c17/iso-ts-14256-1-2003>

© ISO 2003

All rights reserved. Unless otherwise specified, no part of this publication may be reproduced or utilized in any form or by any means, electronic or mechanical, including photocopying and microfilm, without permission in writing from either ISO at the address below or ISO's member body in the country of the requester.

ISO copyright office
Case postale 56 • CH-1211 Geneva 20
Tel. + 41 22 749 01 11
Fax + 41 22 749 09 47
E-mail copyright@iso.org
Web www.iso.org

Published in Switzerland

Contents

Page

Foreword	iv
1 Scope	1
2 Normative references	1
3 Principle	1
4 Handling of the soil samples	1
5 Laboratory sample	2
6 Procedure	2
6.1 Extraction	2
6.2 Determination of the sum of nitrate and nitrite	3
6.3 Determination of nitrite	9
6.4 Determination of ammonium ions	11
7 Test report	13
Bibliography	14

iTeh STANDARD PREVIEW
(standards.iteh.ai)

ISO/TS 14256-1:2003

<https://standards.iteh.ai/catalog/standards/sist/af8d0916-c164-428b-b106-6207f1ce9c17/iso-ts-14256-1-2003>

Foreword

ISO (the International Organization for Standardization) is a worldwide federation of national standards bodies (ISO member bodies). The work of preparing International Standards is normally carried out through ISO technical committees. Each member body interested in a subject for which a technical committee has been established has the right to be represented on that committee. International organizations, governmental and non-governmental, in liaison with ISO, also take part in the work. ISO collaborates closely with the International Electrotechnical Commission (IEC) on all matters of electrotechnical standardization.

International Standards are drafted in accordance with the rules given in the ISO/IEC Directives, Part 2.

The main task of technical committees is to prepare International Standards. Draft International Standards adopted by the technical committees are circulated to the member bodies for voting. Publication as an International Standard requires approval by at least 75 % of the member bodies casting a vote.

In other circumstances, particularly when there is an urgent market requirement for such documents, a technical committee may decide to publish other types of normative document:

- an ISO Publicly Available Specification (ISO/PAS) represents an agreement between technical experts in an ISO working group and is accepted for publication if it is approved by more than 50 % of the members of the parent committee casting a vote;
- an ISO Technical Specification (ISO/TS) represents an agreement between the members of a technical committee and is accepted for publication if it is approved by 2/3 of the members of the committee casting a vote.

An ISO/PAS or ISO/TS is reviewed after three years in order to decide whether it will be confirmed for a further three years, revised to become an International Standard, or withdrawn. If the ISO/PAS or ISO/TS is confirmed, it is reviewed again after a further three years, at which time it must either be transformed into an International Standard or be withdrawn.

Attention is drawn to the possibility that some of the elements of this document may be the subject of patent rights. ISO shall not be held responsible for identifying any or all such patent rights.

ISO/TS 14256-1 was prepared by Technical Committee ISO/TC 190, *Soil quality*, Subcommittee SC 3, *Chemical methods and soil characteristics*.

ISO/TS 14256 consists of the following parts, under the general title *Soil quality — Determination of nitrate, nitrite and ammonium in field-moist soils by extraction with potassium chloride solution*:

- *Part 1: Manual method*
- *Part 2: Automated method*

Soil quality — Determination of nitrate, nitrite and ammonium in field-moist soils by extraction with potassium chloride solution —

Part 1: Manual method

1 Scope

This part of ISO 14256 describes a method for the determination of nitrate, nitrite and ammonium in a 1 mol/l potassium chloride extract of field-moist soil samples.

This part of ISO 14256 is applicable to all types of soils homogenized by suitable methods.

2 Normative references

The following referenced documents are indispensable for the application of this document. For dated references, only the edition cited applies. For undated references, the latest edition of the referenced document (including any amendments) applies.

ISO 3696:1987, *Water for analytical laboratory use — Specification and test methods*.

ISO 11465:1993, *Soil quality — Determination of dry matter and water content on a mass basis — Gravimetric method*.

ISO 14256-2, *Soil quality — Determination of nitrate, nitrite and ammonium in field-moist soils by extraction with potassium chloride solution — Part 2: Automated method*.

3 Principle

The homogenized soil samples are extracted by means of 1 mol/l potassium chloride solution. The concentrations of the inorganic nitrogen compounds nitrate, nitrite and ammonium in the extracts are determined using spectrophotometric methods.

4 Handling of the soil samples

The samples shall be protected from warming during the sampling procedure.

The transportation to the laboratory shall be organized in such a way that no warming occurs. Transportation in a cool box is recommended, especially in late spring and summer.

If the samples are analysed within three days, it is sufficient to store them at 4 °C, otherwise they should be stored at –20 °C (deep-frozen) which enables storing for several weeks, without any significant change in the content of mineral nitrogen.

When the content of mineral nitrogen is determined in deep-frozen soil samples, the temperature and the duration of the thawing process shall be controlled. The samples can be thawed at room temperature, if they are homogenized and extracted within 4 h after beginning of thawing. Thawing at 4 °C is also possible, but the thawing period should not exceed 48 h.

The time period necessary for thawing is greatly influenced by the size of the sample. It is recommended that the soil sample be as small as practicable for the analysis before deep-freezing.

5 Laboratory sample

The laboratory sample is made by homogenizing the original, or the deep-frozen and thawed, soil sample. Homogenizing can be done by mixing thoroughly the total soil sample, either by hand or using a mechanical mixer which ensures that soil aggregates are divided into particles less than 5 mm in diameter.

Use rubber gloves when mixing the soil by hand.

Use part of the laboratory sample to determine the water content in accordance with ISO 11465.

If soil samples cannot be analysed within the time periods given above for fresh soil samples, and therefore have to be deep-frozen, it is recommended to homogenize them before freezing and to freeze only the amount of soil which is necessary for analysis (see Clause 4).

6 Procedure

iTeh STANDARD PREVIEW
(standards.iteh.ai)

6.1 Extraction

6.1.1 Principle

ISO/TS 14256-1:2003

<https://standards.iteh.ai/catalog/standards/sist/af8d0916-c164-428b-b106-000000000000/iso-ts-14256-1-2003>

The field-moist soil is extracted with 1 mol/l potassium chloride solution at a 1:5 ratio (mass concentration) at 20 °C ± 2 °C. After 1 h of extraction, the solution is centrifuged for the determination of inorganic nitrogen compounds on the supernatant solution.

In other climatic conditions, a different constant temperature may be chosen. The extraction temperature used should be mentioned in the test report.

NOTE 1 The extraction is performed at a nearly constant temperature of 20 °C ± 2 °C because the amount of extractable ammonium nitrogen is influenced by the temperature during the extraction.^[1]

Centrifugation is preferred because most filter papers either absorb ammonium or may be contaminated. When the extracts are filtered, the filter papers should be stored at least one week in a desiccator over concentrated sulfuric acid or a drying medium containing sulfuric acid, and the first 20 ml of the filtrate shall be discarded.

Alternatively, clear supernatant solutions may be obtained by letting the soil settle for 4 h at a temperature not exceeding 4 °C.

6.1.2 Reagents

Use only reagents of recognized analytical grade.

6.1.2.1 Water with a specific conductivity not higher than 0,2 mS/m at 25 °C (Grade 2 water according to ISO 3696)

6.1.2.2 Potassium chloride solution, $c(\text{KCl}) = 1 \text{ mol/l}$.

Dissolve 74,55 g of potassium chloride (KCl) in water (6.1.2.1). Make up with water to 1 l.

6.1.3 Apparatus

6.1.3.1 Balances, of accuracy 0,1 g and 0,001 g.

6.1.3.2 Polythene bottles, of nominal volume 500 ml, with screw caps, or other suitable containers which neither absorb nitrite or ammonium nor release it into solution.

6.1.3.3 Shaking machine, end-over-end shaker, frequency 40 min⁻¹.

6.1.3.4 Centrifuge, capable of holding tubes with a nominal volume of 100 ml.

6.1.3.5 Polythene centrifuge tubes, nominal volume 100 ml.

6.1.3.6 Glass vessels, Erlenmeyer type, nominal volume 100 ml.

6.1.4 Procedure

Weigh out 40,0 g of the laboratory sample in the bottle (6.1.3.2). Add 200 ml of potassium chloride solution (6.1.2.2) at a temperature of 20 °C. Shake mechanically (6.1.3.3) for 1 h at 20 ± 2 °C. Decant about 60 ml of the extract suspension in centrifuge tubes (6.1.3.5) and centrifuge (6.1.3.4) for 10 min at about 3 000 *g*. Decant the supernatant solution into glass vessels (6.1.3.6) and measure the content of nitrate, nitrite and ammonium, as described in the following procedures (6.2, 6.3 and 6.4, respectively) using the relevant aliquots.

Perform also a blank test by adding only the potassium chloride solution (6.1.2.2) to the polythene bottle (6.1.3.2).

Measurement of the relevant nitrogen fractions should be performed immediately, but not later than one day after the extraction. If this is not possible, the extracts should be stored at temperatures not higher than 4 °C in a refrigerator, for one week at most.

<https://standards.iteh.ai/catalog/standards/sist/af8d0916-c164-428b-b106-777777777777/iso-ts-14256-1-2003>

NOTE Rather than using the following manual methods, continuous flow analysis is also possible. The methods are given in ISO 14256-2.

6.2 Determination of the sum of nitrate and nitrite

6.2.1 Principle

Nitrate in the soil extract is reduced to nitrite by passing the extract through a reduction column containing copperized cadmium powder. Nitrite originally present in the soil, which is produced by reduction, forms a diazo compound in acid medium after the addition of sulfanilamide and *N*-(1-naphthyl)ethylenediamine dihydrochloride (Griess-Ilosvay reagent). Its absorbance is measured at a wavelength of 543 nm.

Under aerobic conditions, the content of nitrite in soils is negligible. In this case, the determination of the content of nitrite is not necessary, and the method gives the content of nitrate directly.

6.2.2 Apparatus

Ordinary laboratory equipment, and the following.

6.2.2.1 Reduction column in accordance with Figure 1.

Dimensions in millimetres

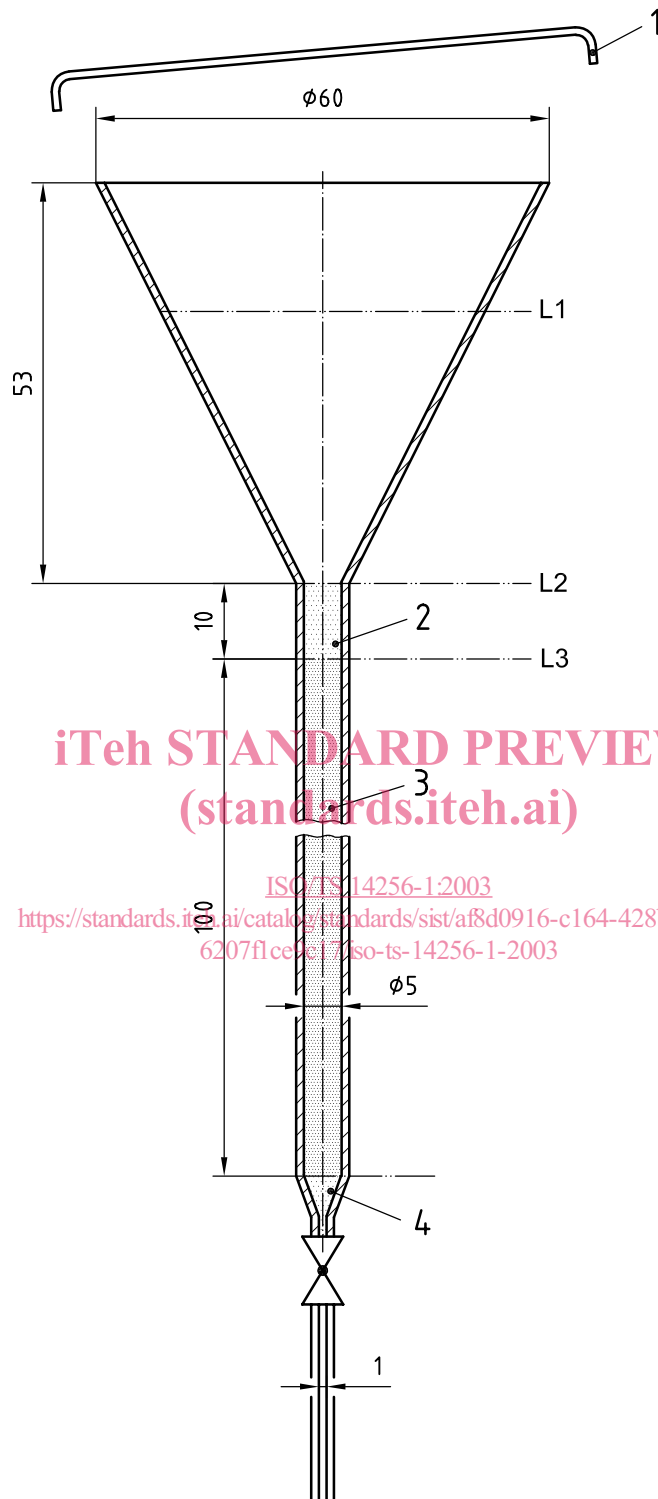

iTeh STANDARD PREVIEW
(standards.iteh.ai)

ISO/TS 14256-1:2003
<https://standards.iteh.ai/catalog/standards/sist/af8d0916-c164-428b-b106-6207f1ce7c17/iso-ts-14256-1-2003>

Key

- 1 lid
- 2 plug made of cotton wool (6.2.2.3)
- 3 coarse cadmium powder (6.2.3.7)
- 4 plug made of cotton wool (6.2.2.3)

Figure 1 — Column for reduction of nitrate to nitrite

6.2.2.2 Spectrometer, suitable for measurements at a wavelength of 543 nm, together with cells of 10 mm optical length.

6.2.2.3 Wool, clean and chemically resistant, free of free nitrogen, for example cotton wool.

6.2.2.4 pH-meter with glass electrode and reference electrode or a combined electrode of equivalent performance.

6.2.3 Reagents

6.2.3.1 Water with a specific conductivity not higher than 0,2 mS/m at 25 °C (water of Grade 2 in accordance with ISO 3696).

6.2.3.2 Sodium nitrate (NaNO_3).

6.2.3.2.1 Nitrate stock solution, $\rho(\text{NO}_3\text{-N}) = 600 \text{ mg/l}$.

Dissolve 3,641 g of sodium nitrate (6.2.3.2) in water and make up to 1 l with water.

This solution is stable up to 6 months, when stored in glass bottles in darkness at 4 °C.

6.2.3.2.2 Nitrate standard solution, $\rho(\text{NO}_3\text{-N}) = 6 \text{ mg/l}$.

Pipette 10 ml of stock solution (6.2.3.2.1) into a volumetric flask of 1 l and make up to the mark with water. This solution should be prepared daily.

6.2.3.3 Sodium nitrite (NaNO_2).

6.2.3.3.1 Nitrite stock solution, $\rho(\text{NO}_2\text{-N}) = 600 \text{ mg/l}$.

Dissolve 2,958 g of sodium nitrite (6.2.3.3) in water and make up to 1 l with water.

This solution is stable up to 6 months, when stored in glass bottles in darkness at 4 °C.

6.2.3.3.2 Nitrite standard solution, $\rho(\text{NO}_2\text{-N}) = 6 \text{ mg/l}$.

Pipette 10 ml of stock solution (6.2.3.3.1) into a volumetric flask of 1 l and make up to the mark with water. This solution should be prepared daily.

6.2.3.4 Ammonium chloride (NH_4Cl).

6.2.3.5 Ammonia solution, $w(\text{NH}_4\text{OH}) = 6 \%$. Dissolve about 250 ml of concentrated ammonia solution, $w(\text{NH}_4\text{OH}) = 32 \%$, into about 500 ml of water. Make up to 1 l with water.

6.2.3.6 Buffer solution of ammonium chloride (pH 8.7 to 8.8).

6.2.3.6.1 Stock solution, $\rho(\text{NH}_4\text{Cl}) = 100 \text{ g/l}$.

Dissolve, in a volumetric flask, 100 g of ammonium chloride (6.2.3.4) in approximately 0,8 l of water. Adjust the pH to between 8,7 and 8,8 with ammonia solution (6.2.3.5), and make up to 1 l with water.

6.2.3.6.2 Diluted buffer solution, $\rho(\text{NH}_4\text{Cl}) = 10 \text{ g/l}$.

Dilute 100 ml of stock solution (6.2.3.6.1) to 1 l with water.

6.2.3.7 Coarse cadmium powder (particle size 0,3 mm to 0,8 mm).

6.2.3.8 Phosphoric acid, $w(\text{H}_3\text{PO}_4) = 80 \%$.

6.2.3.9 Hydrochloric acid, $\rho(\text{HCl}) = 1,12 \text{ kg/l}$.

6.2.3.10 Sulfanilamide, $\text{C}_6\text{H}_8\text{N}_2\text{O}_2\text{S}$.

6.2.3.11 Sulfanilamide solution.

In a 1 000 ml volumetric flask containing approximately 600 ml of water, add 200 ml of phosphoric acid (6.2.3.8), mix and dissolve 80 g of sulfanilamide (6.2.3.10) therein. Make up to the mark with water. This solution can be stored for at least one year in a refrigerator.

6.2.3.12 *N*-(1-naphthyl)ethylenediamine dihydrochloride, $\text{C}_{12}\text{H}_{16}\text{N}_2\text{Cl}_2$.

6.2.3.12.1 *N*-(1-naphthyl)ethylenediamine dihydrochloride solution.

Dissolve 0,40 g of *N*-(1-naphthyl)ethylenediamine dihydrochloride (6.2.3.12) in 100 ml of water. This solution shall be stored in a refrigerator. Discard the reagent when its colour becomes dark.

6.2.3.13 Colour reagent.

Mix 20 ml of sulfanilamide solution (6.2.3.11), 20 ml of *N*-(1-naphthyl)ethylenediamine dihydrochloride solution (6.2.3.12.1) and 20 ml of phosphoric acid (6.2.3.8). Store this solution in a refrigerator and discard it when its colour becomes dark.

6.2.3.14 Copper sulfate, $\text{CuSO}_4 \cdot 5 \text{H}_2\text{O}$.

iTeh STANDARD PREVIEW
(standards.iteh.ai)

6.2.4 Preparations for the reduction step

ISO/TS 14256-1:2003

6.2.4.1 Preparation of copperized cadmium

<https://standards.iteh.ai/catalog/standards/sist/af8d0916-c164-428b-b106-6207f1ce9c17/iso-ts-14256-1-2003>

Cover approximately 10 g of cadmium powder (6.2.3.7) with hydrochloric acid (6.2.3.9) and mix 10 min. Then wash at least five times with water.

After rinsing, cover the cadmium powder with water. Then add about 0,5 g of copper sulfate (6.2.3.14). Mix 1 min. Then wash at least ten times with water until any flocculated black copper is removed.

Cover the powder again with hydrochloric acid (6.2.3.9) and mix 1 min. Then wash at least five times with water.

The cadmium powder thus prepared shall be used within 1 h for preparing the reduction column (6.2.4.2). Keep it in water until use.

6.2.4.2 Preparation of the reduction column

Figure 1 shows a reduction column of recommended size. To fill and empty it easily, the middle part of the column should be made of silica.

Place a small plug of wool (6.2.2.3) in the bottom of the column. Then fill the column with water until level L1 is reached and turn off the tap. Add the copperized cadmium (6.2.4.1) to the column slowly, until level L3 is reached (see Figure 1).

Tap the column during the filling process to settle the cadmium. Place a small plug of wool on the top of the column.

NOTE 1 This plug stops further efflux, when the surface of the effluent solution has reached level L2. It also acts as a filter which can be replaced when necessary.

If the column is not used within 1 h, pour diluted buffer solution (6.2.3.6.2) in it, until level L1 is reached. Let drain about 2 ml. Then close the stopcock. Put a lid on the surface of the funnel to avoid evaporation and to protect from dust. In this way, the column can be preserved during several weeks. However, check the column efficiency according to 6.2.5.5, before using it again.

NOTE 2 Prepared cadmium which is not needed immediately for filling the column can be dried and stored for further re-preparation.

6.2.5 Procedure

6.2.5.1 Preparation of the reduction column for each series of analyses

Open the stopcock. Let the diluted buffer solution drain out of the column. If necessary, rinse the funnel copiously with water to remove salt from its surface.

Percolate through the column:

- 20 ml of diluted buffer solution (6.2.3.6.2);
- 20 ml of concentrated buffer solution (6.2.3.6.1);
- 20 ml of diluted buffer solution (6.2.3.6.2).

When these volumes of buffer have passed through, the column is ready for a series of reduction procedures.

6.2.5.2 Reduction steps

Close the stopcock. Carry out the reduction on each of the following solutions, as follows.

Pour in 1,00 ml of <https://standards.iteh.ai/catalog/standards/sist/af8d0916-c164-428b-b106-6207f1ce9c17/iso-ts-14256-1-2003>

- either blank extract solution (BE) obtained according to 6.1.4;
- or extract solution (SE) obtained according to 6.1.4;
- or nitrate standard solution (NAS) (6.2.3.2.2);
- or nitrite standard solution (NIS) (6.2.3.3.2);
- or zero standard solution (ZS) (water).

After passage of each solution, carry out the following steps.

- a) Add 10 ml of buffer (6.2.3.6.2) to the funnel.
- b) Open the stopcock and collect the eluent in a 30 ml tube. Percolation stops when the surface of the solution reaches the top of the wool plug (6.2.2.3) at level L2 (see Figure 1). At this moment, add a further 20 ml of buffer (6.2.3.6.2) into the funnel. When this has drained, remove the collecting tube. Rinse the column with a further 10 ml of buffer (6.2.3.6.2).

6.2.5.3 Colour development

Add 0,20 ml of colour reagent (6.2.3.13) into each tube containing the reduced eluents. Mix well. Let stand between 60 min and 90 min at room temperature.