

---

---

**Geosynthetics — Determination of the  
protection efficiency of a geosynthetic  
against impact damage**

*Géosynthétiques — Détermination de l'efficacité de protection d'un  
géosynthétique contre l'effet d'un impact*

**iTeh STANDARD PREVIEW**  
**(standards.iteh.ai)**

[ISO 13428:2005](https://standards.iteh.ai/catalog/standards/sist/0adda82b-9885-4f20-bc0f-616f31d761ef/iso-13428-2005)

[https://standards.iteh.ai/catalog/standards/sist/0adda82b-9885-4f20-bc0f-  
616f31d761ef/iso-13428-2005](https://standards.iteh.ai/catalog/standards/sist/0adda82b-9885-4f20-bc0f-616f31d761ef/iso-13428-2005)



**PDF disclaimer**

This PDF file may contain embedded typefaces. In accordance with Adobe's licensing policy, this file may be printed or viewed but shall not be edited unless the typefaces which are embedded are licensed to and installed on the computer performing the editing. In downloading this file, parties accept therein the responsibility of not infringing Adobe's licensing policy. The ISO Central Secretariat accepts no liability in this area.

Adobe is a trademark of Adobe Systems Incorporated.

Details of the software products used to create this PDF file can be found in the General Info relative to the file; the PDF-creation parameters were optimized for printing. Every care has been taken to ensure that the file is suitable for use by ISO member bodies. In the unlikely event that a problem relating to it is found, please inform the Central Secretariat at the address given below.

**iTeh STANDARD PREVIEW**  
**(standards.iteh.ai)**

ISO 13428:2005

<https://standards.iteh.ai/catalog/standards/sist/0adda82b-9885-4f20-bc0f-616f31d761ef/iso-13428-2005>

© ISO 2005

All rights reserved. Unless otherwise specified, no part of this publication may be reproduced or utilized in any form or by any means, electronic or mechanical, including photocopying and microfilm, without permission in writing from either ISO at the address below or ISO's member body in the country of the requester.

ISO copyright office  
Case postale 56 • CH-1211 Geneva 20  
Tel. + 41 22 749 01 11  
Fax + 41 22 749 09 47  
E-mail [copyright@iso.org](mailto:copyright@iso.org)  
Web [www.iso.org](http://www.iso.org)

Published in Switzerland

**Contents**

Page

<b>Foreword</b> .....	<b>iv</b>
<b>1 Scope</b> .....	<b>1</b>
<b>2 Normative references</b> .....	<b>1</b>
<b>3 Terms and definitions</b> .....	<b>1</b>
<b>4 Principle</b> .....	<b>2</b>
<b>5 Test specimens</b> .....	<b>3</b>
<b>6 Apparatus (see Figure 1)</b> .....	<b>3</b>
<b>7 Test procedure</b> .....	<b>5</b>
<b>8 Calculation</b> .....	<b>6</b>
<b>9 Test report</b> .....	<b>7</b>
<b>Annex A (informative) Performance testing</b> .....	<b>8</b>
<b>Bibliography</b> .....	<b>9</b>

**iTeh STANDARD PREVIEW**  
**(standards.iteh.ai)**

[ISO 13428:2005](https://standards.iteh.ai/catalog/standards/sist/0adda82b-9885-4f20-bc0f-616f31d761ef/iso-13428-2005)

<https://standards.iteh.ai/catalog/standards/sist/0adda82b-9885-4f20-bc0f-616f31d761ef/iso-13428-2005>

## Foreword

ISO (the International Organization for Standardization) is a worldwide federation of national standards bodies (ISO member bodies). The work of preparing International Standards is normally carried out through ISO technical committees. Each member body interested in a subject for which a technical committee has been established has the right to be represented on that committee. International organizations, governmental and non-governmental, in liaison with ISO, also take part in the work. ISO collaborates closely with the International Electrotechnical Commission (IEC) on all matters of electrotechnical standardization.

International Standards are drafted in accordance with the rules given in the ISO/IEC Directives, Part 2.

The main task of technical committees is to prepare International Standards. Draft International Standards adopted by the technical committees are circulated to the member bodies for voting. Publication as an International Standard requires approval by at least 75 % of the member bodies casting a vote.

Attention is drawn to the possibility that some of the elements of this document may be the subject of patent rights. ISO shall not be held responsible for identifying any or all such patent rights.

ISO 13428 was prepared by the European Committee for Standardization (CEN) Technical Committee CEN/TC 189, *Geosynthetics*, in collaboration with Technical Committee ISO/TC 221, *Geosynthetics*, in accordance with the Agreement on technical cooperation between ISO and CEN (Vienna Agreement).

ITEH STANDARD PREVIEW

(standards.iteh.ai)

ISO 13428:2005

<https://standards.iteh.ai/catalog/standards/sist/0adda82b-9885-4f20-bc0f-616f31d761ef/iso-13428-2005>

# Geosynthetics — Determination of the protection efficiency of a geosynthetic against impact damage

## 1 Scope

This International Standard describes an index test for the determination of the protection efficiency of a geosynthetic on a hard surface, exposed to the impact load of a hemispherical object.

The index test measures the change in thickness of a thin lead plate lying between the geosynthetic and a rigid support.

It can also be used as a performance test, by using the real rigid surface to protect and the real sequence of geosynthetics.

The test is applicable to all geosynthetics with apertures smaller than 15 mm (maximum size).

## 2 Normative references

iTeh STANDARD PREVIEW  
(standards.iteh.ai)

The following referenced documents are indispensable for the application of this document. For dated references, only the edition cited applies. For undated references, the latest edition of the referenced document (including any amendments) applies.

ISO 554, *Standard atmospheres for conditioning and/or testing — Specifications*

ISO 9862, *Geosynthetics — Sampling and preparation of test specimens*

ISO 9863-1, *Geosynthetics — Determination of thickness at specified pressure — Part 1: Single layers*

ISO 9864, *Geosynthetics — Test method for the determination of mass per unit area of geotextiles and geotextile-related products*

EN 12588, *Lead and lead alloys — Rolled lead sheet for building purposes*

## 3 Terms and definitions

For the purposes of this document, the following terms and definitions apply.

### 3.1 plate thickness

$s$   
thickness of the thin lead plate

NOTE Plate thickness is expressed in millimetres.

**3.2**  
**initial plate thickness**

$s_i$   
plate thickness under an applied pressure of 2 kPa

NOTE Initial plate thickness is expressed in millimetres.

**3.3**  
**residual plate thickness**

$s_r$   
plate thickness after an impact, in the centre of the impact area

NOTE Residual plate thickness is expressed in millimetres.

**3.4**  
**probe**  
hemispherical mass used to produce the impact on the geosynthetic specimen

NOTE The probe is shown in Figure 3.

**3.5**  
**nominal specimen thickness**

$t_n$   
thickness of the specimen when subjected to an applied normal stress of 2 kPa, when measured in accordance with ISO 9863-1

NOTE Nominal specimen thickness is expressed in millimetres.

**iTeh STANDARD PREVIEW**  
**(standards.iteh.ai)**

**4 Principle**

ISO 13428:2005

<https://standards.iteh.ai/catalog/standards/sist/0adda82b-9885-4e20-bc0f-61651d701c18/iso-13428-2005>

A geosynthetic test specimen is subjected to an impact load produced by a rigid probe with a hemispherical head. The probe hits the specimen with a known energy.

The specimen lies on a rigid support, consisting of a thick steel plate of set characteristics and dimensions. A thin lead plate is placed between the steel plate and the specimen.

The five specimens are each subjected to one impact. A single lead plate can be used for all five specimens.

The residual thickness of the lead plate is measured in the impacted areas and the average residual thickness is calculated.

The impact energy is given by:

$$E = F \times h \tag{1}$$

where

$E$  is the impact energy, in joules;

$F$  is the weight of the probe, in newtons;

$h$  is the distance between top surface of the specimen and bottom point of the probe, in metres.

## 5 Test specimens

### 5.1 Sampling

Take specimens in accordance with ISO 9862.

### 5.2 Number and dimensions of test specimens

Cut five specimens for each face from the test sample. A new set of specimens is required for each test.

Specimens shall meet the following criteria:

- the shape of the specimen shall be square (see Figure 2);
- the minimum size of the specimen shall be 100 mm × 100 mm (see Figure 2).

### 5.3 Conditioning

The test specimens shall be conditioned in the standard atmosphere for testing at  $(20 \pm 2) ^\circ\text{C}$  and  $(65 \pm 5) \%$  relative humidity as defined in ISO 554.

The specimens can be considered to be conditioned when the change in mass in successive weighings made at intervals of not less than 2 h does not exceed 0,25 % of the mass of the test specimen.

Conditioning and/or testing in the standard atmosphere may only be omitted when it can be shown that results obtained for the same specific type of product (both structure and polymer type) are not affected by changes in temperature and humidity exceeding the limits. This information shall be included in the test report.

ISO 13428:2005

## 6 Apparatus (see Figure 1)

<https://www.it-ebooks.info/catalog/standards/sist/0adda82b-9885-4f20-bc0f-616f31d761ef/iso-13428-2005>

### 6.1 Probe

The probe is made of a steel cylinder with a hemispherical head of 20 mm diameter. It is fixed to a trigger (Figure 3).

NOTE The probe may move inside a large tube, e.g. acrylic glass, to provide protection for the operator. For performance tests, weight and diameter of the probe and the falling height can be varied in order to model the real situation.

For index tests, the falling height shall be  $(1 \pm 0,01)$  m and the mass of the probe shall be  $(1\ 000 \pm 2)$  g.

### 6.2 Specimen support

The specimen support with all the relevant dimensions is shown in Figure 2.

It consists of a 40 mm thick steel plate, as shown in Figure 2. The steel plate shall have minimum dimensions equal to or exceeding those of the specimens.

The steel plate shall be put on a flat rigid support, like a concrete floor, which will not bend or settle during the impact. No soft or deformable base shall be used. Before starting the test, it shall be checked that the steel plate lays perfectly on the support and that no vibration occurs when the probe impacts the specimens.

NOTE For this test, the same tube and trigger system as for the cone drop test (EN 918) may be used.

6.3 Lead plate

A soft lead plate, grade 3 according to EN 12588, is placed on the top slab. The lead plate shall have a nominal thickness of 1,8 mm. Since the actual thickness of the lead plates can have local variations of up to 20 % compared to its nominal thickness, the initial thickness in each impact area shall be measured and reported. If the initial thickness of the plate is outside the limits of  $(1,8 \pm 0,2)$  mm, the plate shall be discarded. The lead plate shall have minimum dimensions of 60 mm × 60 mm. When the specimen is larger than 60 mm, the lead plate's size shall be increased accordingly. Then the specimen shall be placed on the metal plate as shown in Figure 2.

Dimensions in millimetres

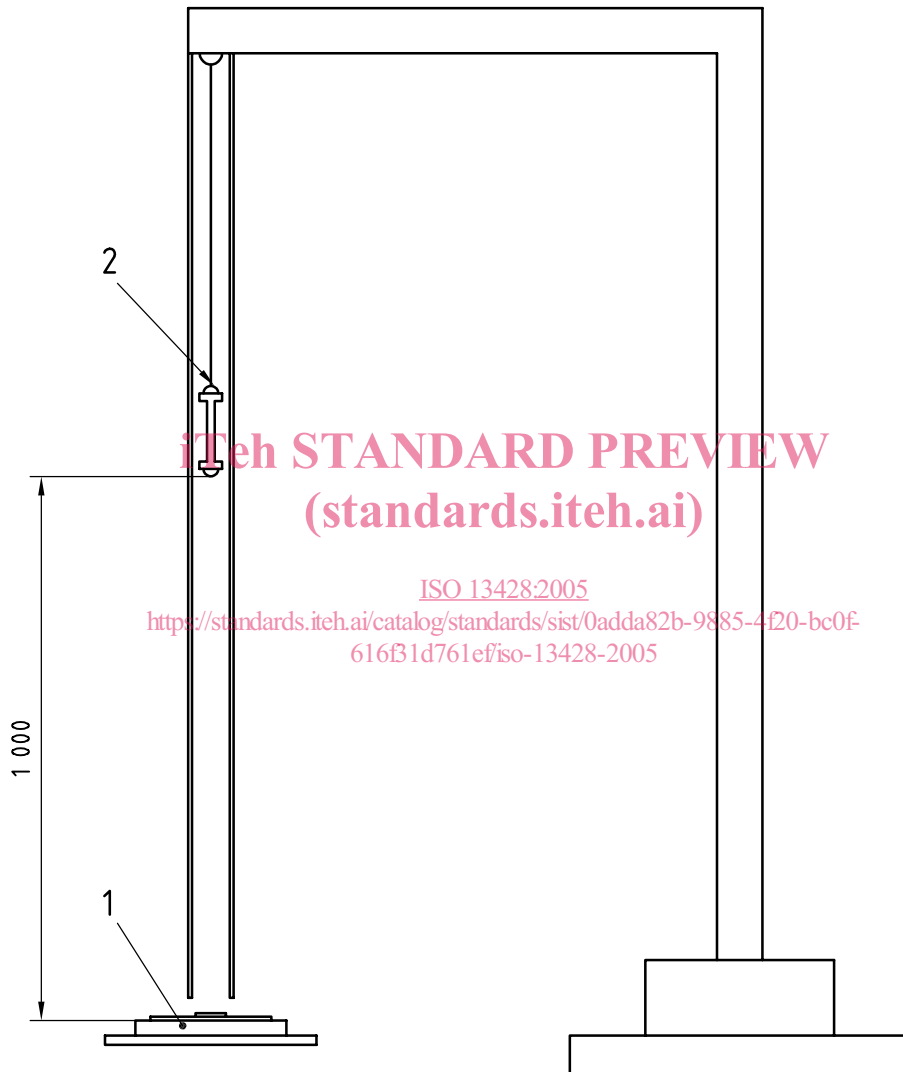

Key

- 1 specimen support
- 2 probe

Figure 1 — Scheme of the testing apparatus

6.4 Thickness gauge

The thickness gauge can be a comparator, or any device able to measure the thickness of a locally deformed metal plate with an accuracy of  $\pm 0,01$  mm.

The device shall be capable of measuring under an applied pressure of 2 kPa.

The contact element of the thickness gauge shall have rounded tips with a diameter of 0,50 mm.



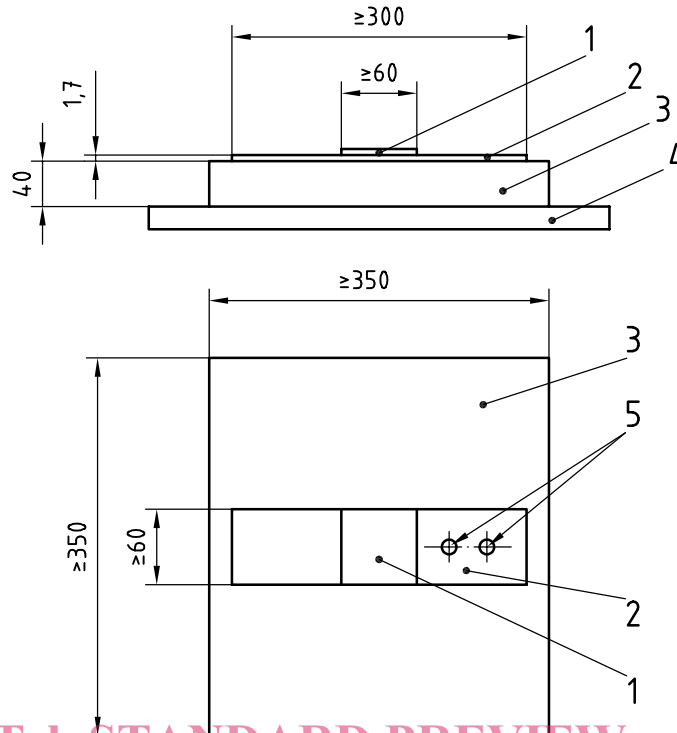

iTeh STANDARD PREVIEW  
(standards.iteh.ai)

#### Key

- 1 specimen
- 2 lead plate
- 3 steel platen
- 4 rigid base or floor
- 5 previous impacts

ISO 13428:2005

<https://standards.iteh.ai/catalog/standards/sist/0adda82b-9885-4f20-bc0f-616f31d761ef/iso-13428-2005>

Figure 2 — Specimen support

## 7 Test procedure

Measure the probe head diameter and the falling height of the probe from its lowest point when mounted in the guide tube.

Measure the initial thickness  $s_i$  of the lead plate, the nominal thickness  $t_n$  of each specimen, in accordance with ISO 9863-1, and mass per unit area  $\rho$  of each specimen in accordance with ISO 9864.

Assemble the steel plate, the lead plate and the first specimen.

Load the probe in the starting position and release the trigger.

Remove the specimen.

Place a new lead plate and a new specimen on the lead plate.

Impact the specimen with the probe.

Repeat for all specimens of the same face. Repeat for the specimens of the other face.

Measure the minimum residual thickness  $t_r$  of the lead plates in the impact areas with the thickness gauge.