



SLOVENSKI STANDARD

SIST ISO 5673-1:2015

01-april-2015

Nadomešča:
SIST ISO 5673:1995

**Kmetijski traktorji in stroji - Priključne gredi in namestitvev priključkov - 1. del:
Splošno proizvodne in varnostne zahteve**

Agricultural tractors and machinery - Power take-off drive shafts and power-input connection - Part 1: General manufacturing and safety requirements

iTeh STANDARD PREVIEW
(standards.iteh.ai)

Tracteurs et matériels agricoles - Arbres de transmission à cardans de prise de force et arbre récepteur de la machine - Partie 1: Exigences générales de fabrication et de sécurité

<https://standards.iteh.ai/catalog/standards/sist/bb3e2902-c50e-4292-8c5e-5028966daddb/sist-iso-5673-1-2015>

Ta slovenski standard je istoveten z: ISO 5673-1:2005

ICS:

65.060.10 Kmetijski traktorji in prikolice Agricultural tractors and
trailed vehicles

SIST ISO 5673-1:2015

en,fr

iTeh STANDARD PREVIEW
(standards.iteh.ai)

SIST ISO 5673-1:2015

<https://standards.iteh.ai/catalog/standards/sist/bb3e2902-c50e-4292-8c5e-5028966daddb/sist-iso-5673-1-2015>

INTERNATIONAL
STANDARD

ISO
5673-1

First edition
2005-02-15

**Agricultural tractors and machinery —
Power take-off drive shafts and power-
input connection —**

Part 1:
**General manufacturing and safety
requirements**

iTeh STANDARD PREVIEW
(standards.iteh.ai)

*Tracteurs et matériels agricoles — Arbres de transmission à cardans de
prise de force et arbre récepteur de la machine —*

Partie 1. Exigences générales de fabrication et de sécurité

<https://standards.iteh.ai/catalog/standards/sist/b63e2902-c50e-4292-8c5e-5028966daddb/sist-iso-5673-1-2015>



Reference number
ISO 5673-1:2005(E)

© ISO 2005

ISO 5673-1:2005(E)**PDF disclaimer**

This PDF file may contain embedded typefaces. In accordance with Adobe's licensing policy, this file may be printed or viewed but shall not be edited unless the typefaces which are embedded are licensed to and installed on the computer performing the editing. In downloading this file, parties accept therein the responsibility of not infringing Adobe's licensing policy. The ISO Central Secretariat accepts no liability in this area.

Adobe is a trademark of Adobe Systems Incorporated.

Details of the software products used to create this PDF file can be found in the General Info relative to the file; the PDF-creation parameters were optimized for printing. Every care has been taken to ensure that the file is suitable for use by ISO member bodies. In the unlikely event that a problem relating to it is found, please inform the Central Secretariat at the address given below.

iTeh STANDARD PREVIEW (standards.iteh.ai)

[SIST ISO 5673-1:2015](https://standards.iteh.ai/catalog/standards/sist/bb3e2902-c50e-4292-8c5e-5028966daddb/sist-iso-5673-1-2015)

<https://standards.iteh.ai/catalog/standards/sist/bb3e2902-c50e-4292-8c5e-5028966daddb/sist-iso-5673-1-2015>

© ISO 2005

All rights reserved. Unless otherwise specified, no part of this publication may be reproduced or utilized in any form or by any means, electronic or mechanical, including photocopying and microfilm, without permission in writing from either ISO at the address below or ISO's member body in the country of the requester.

ISO copyright office
Case postale 56 • CH-1211 Geneva 20
Tel. + 41 22 749 01 11
Fax + 41 22 749 09 47
E-mail copyright@iso.org
Web www.iso.org

Published in Switzerland

Contents

Page

Foreword	iv
1 Scope	1
2 Normative references	1
3 Terms and definitions	1
4 Manufacturing requirements	7
5 Safety requirements	9
6 Information for use	16
Bibliography	19

iTeh STANDARD PREVIEW
(standards.iteh.ai)

[SIST ISO 5673-1:2015](https://standards.iteh.ai/catalog/standards/sist/bb3e2902-c50e-4292-8c5e-5028966daddb/sist-iso-5673-1-2015)

<https://standards.iteh.ai/catalog/standards/sist/bb3e2902-c50e-4292-8c5e-5028966daddb/sist-iso-5673-1-2015>

ISO 5673-1:2005(E)

Foreword

ISO (the International Organization for Standardization) is a worldwide federation of national standards bodies (ISO member bodies). The work of preparing International Standards is normally carried out through ISO technical committees. Each member body interested in a subject for which a technical committee has been established has the right to be represented on that committee. International organizations, governmental and non-governmental, in liaison with ISO, also take part in the work. ISO collaborates closely with the International Electrotechnical Commission (IEC) on all matters of electrotechnical standardization.

International Standards are drafted in accordance with the rules given in the ISO/IEC Directives, Part 2.

The main task of technical committees is to prepare International Standards. Draft International Standards adopted by the technical committees are circulated to the member bodies for voting. Publication as an International Standard requires approval by at least 75 % of the member bodies casting a vote.

Attention is drawn to the possibility that some of the elements of this document may be the subject of patent rights. ISO shall not be held responsible for identifying any or all such patent rights.

ISO 5673-1 was prepared by Technical Committee ISO/TC 23, *Tractors and machinery for agriculture and forestry*, Subcommittee SC 4, *Tractors*.

This first edition of ISO 5673-1, together with ISO 5673-2, cancels and replaces ISO 5673:1993, of which it constitutes a technical revision.

ISO 5673 consists of the following parts, under the general title *Agricultural tractors and machinery — Power take-off drive shafts and power-input connection*:

- *Part 1: General manufacturing and safety requirements*
- *Part 2: Specification for use of PTO drive shafts, and position and clearance of PTO drive line and PIC for various attachments*

iTeh STANDARD PREVIEW
(standards.iteh.ai)

SIST ISO 5673-1:2015
<https://standards.iteh.ai/catalog/standards/sist/bb3e2902-c50e-4292-8c5e-5028966daddb/sist-iso-5673-1-2015>

Agricultural tractors and machinery — Power take-off drive shafts and power-input connection —

Part 1: General manufacturing and safety requirements

1 Scope

This part of ISO 5673 specifies the power take-off (PTO) drive shafts of a tractor or self-propelled machine used in agriculture and the power-input connection (PIC) of its implement, establishing a method for determining PTO static and dynamic torsional strength while giving manufacturing and safety requirements. It is applicable only to those PTO drive shafts and guards mechanically linked to the shaft by at least two bearings. It is not applicable to PTO drive shafts guarded by location or to the mechanical characteristics of overrun devices and torque limiters, nor are environmental aspects considered; neither is it applicable to PTO drive shafts and their guards manufactured before the date of its publication.

2 Normative references

The following referenced documents are indispensable for the application of this document. For dated references, only the edition cited applies. For undated references, the latest edition of the referenced document (including any amendments) applies.

ISO 500-3:2004, *Agricultural tractors — Rear mounted power take-off types 1, 2 and 3 — Part 3: Main PTO dimensions and spline dimensions, location of PTO*

ISO 4254-1, *Agricultural machinery — Safety — Part 1: General requirements*¹⁾

ISO 5674:2004, *Tractors and machinery for agriculture and forestry — Guards for power take-off (PTO) drive-shafts — Strength and wear tests and acceptance criteria*

ISO 11684:1995, *Tractors, machinery for agriculture and forestry, powered lawn and garden equipment — Safety signs and hazard pictorials — General principles*

3 Terms and definitions

For the purposes of this document, the following terms and definitions apply.

3.1

power take-off (PTO) drive shaft

assembly consisting of two joints, telescopic members and a guard which is mechanically linked to the shaft by at least two bearings used to transmit rotational power from the PTO of a tractor or self-propelled machine to an implement and/or between parts of the implement

1) To be published. (Revision of ISO 4254-1:1989)

ISO 5673-1:2005(E)

3.1.1 primary PTO drive shaft

detachable PTO drive shaft linking the PTO of the tractor or self-propelled machine to the PIC of an implement

See Figure 1.

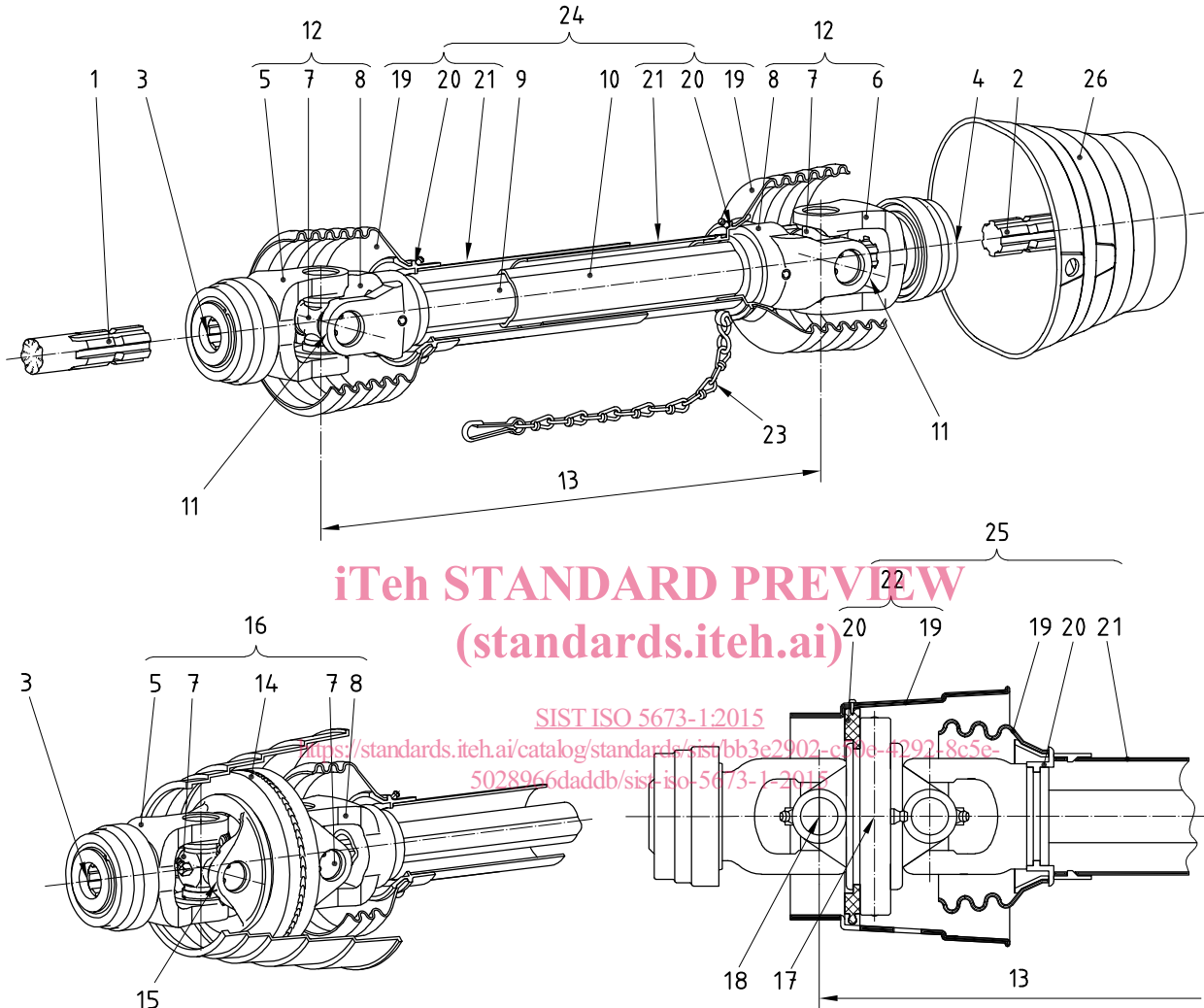

Key

- | | | | |
|----|---|----|--|
| 1 | power take off shaft (PTO) | 14 | double yoke |
| 2 | power-input connection (PIC) | 15 | end of double yoke of outer joint |
| 3 | PTO yoke bore | 16 | wide-angle universal joint |
| 4 | PIC yoke bore | 17 | centre of articulation of wide-angle universal joint |
| 5 | PTO yoke | 18 | centre of outer joint |
| 6 | PIC yoke | 19 | guard cone |
| 7 | journal cross-assembly | 20 | guard bearing |
| 8 | inner yoke | 21 | guard tube |
| 9 | inner telescopic member | 22 | separate guard of wide angle universal joint |
| 10 | outer telescopic member | 23 | restraining member (as an example) |
| 11 | end of inner yoke of universal joint | 24 | PTO drive shaft guard |
| 12 | universal joint | 25 | PTO wide-angle drive shaft guard |
| 13 | PTO drive shaft, closed and extended length | 26 | PIC guard |

Figure 1 — Primary PTO drive shaft, power-input connection and associated components

3.1.2**secondary PTO drive shaft**

PTO drive shaft, detachable or otherwise, following the PIC of an implement and having the same basic design as a primary PTO drive shaft

See Figure 2.

3.2**PTO drive shaft attachment**

shaft to which a PTO drive shaft is connected

3.2.1**power take-off shaft****PTO**

external shaft on the rear of the tractor providing rotational power to an implement by means of a primary PTO drive shaft

See Figure 2.

3.2.2**power input connection****PIC**

first power input connection, in the form of a shaft on the implement, to which a primary PTO drive shaft is connected

See Figure 2.

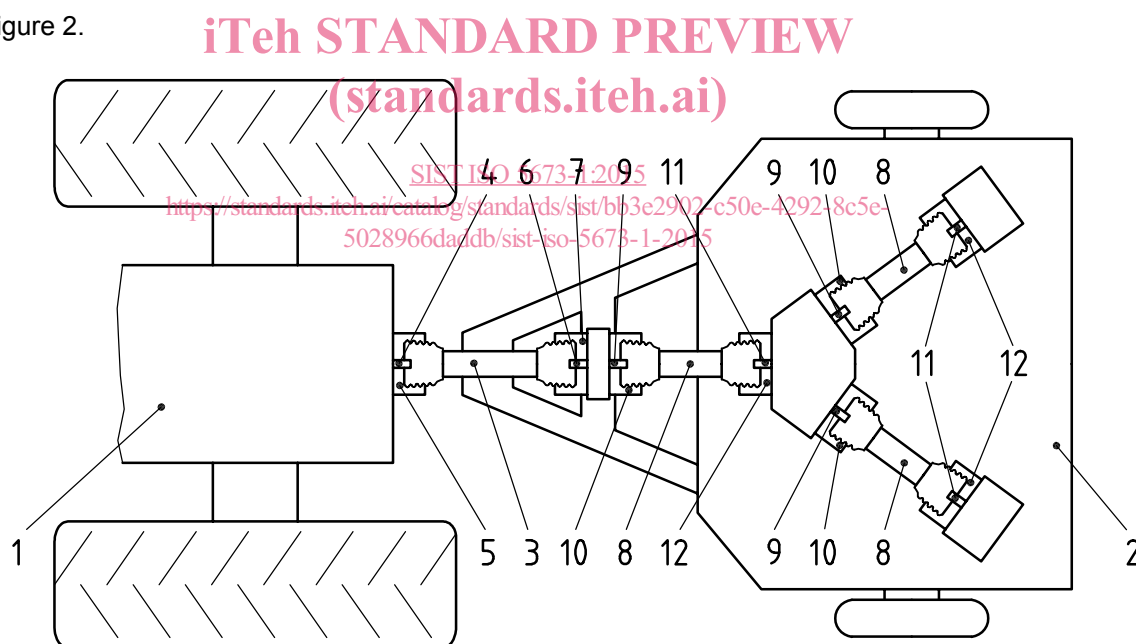
**Key**

1	tractor	7	PIC guard
2	implement	8	secondary PTO drive shaft
3	primary PTO drive shaft	9	SPTO
4	PTO	10	SPTO guard
5	PTO master shield	11	SPIC
6	PIC	12	SPIC guard

Figure 2 — Example of arrangement of PTO drive shafts

ISO 5673-1:2005(E)

3.2.3

secondary power take-off**SPTO**

external shaft on the implement drive line providing rotational power to parts of the implement by means of a secondary PTO drive shaft

See Figure 2.

3.2.4

secondary power input connection**SPIC**

secondary power input connection as a shaft on the implement to which a secondary PTO drive shaft is connected

See Figure 2.

3.3

closed length

⟨PTO drive shaft⟩ distance between the centres of the outermost journal cross-assemblies of the shaft as specified by the manufacturer, when the PTO drive shaft is fully closed

3.4

extended length

⟨PTO drive shaft⟩ distance between the centres of the outermost journal cross-assemblies of the shaft when the PTO drive shaft is extended to the maximum operational length as specified by the manufacturer

3.5

universal joint

mechanical device which can transmit torque and/or rotational motion from one shaft to another at fixed or varying angles of intersection of the shaft axes

iTeh STANDARD PREVIEW
(standards.iteh.ai)

[SIST ISO 5673-1:2015](https://standards.iteh.ai/catalog/standards/sist/bb3e2902-c50e-4292-8c5e-3966daddb/sist-iso-5673-1-2015)

3.6

wide-angle constant velocity universal joint

constant-velocity joint allowing operation with an articulation generally higher than 50°, while motion is transmitted uniformly

3.7

overrun device

device that permits the transmission of motion in only one direction, from the tractor towards the implement

See Figure 3.

NOTE It is normally used with a recipient machine having high-value inertia.

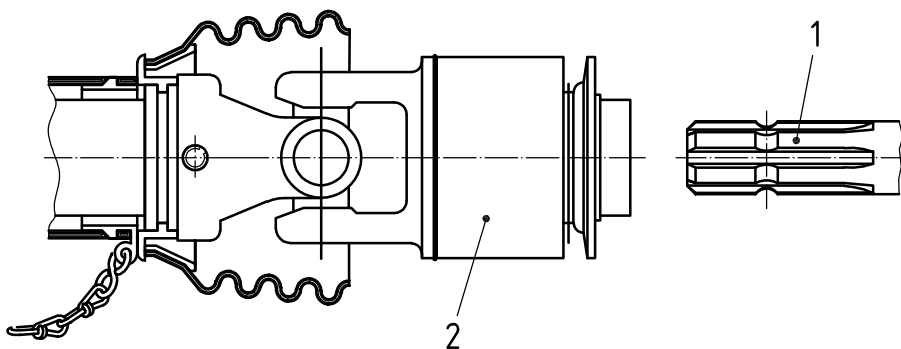
**Key**

- 1 PIC
- 2 overrun device

Figure 3 — Example of overrun device

3.8**torque limiter**

device that cuts or limits the transmission of motion between tractor and implement when the torque reaches a prefixed value

See Figure 4.

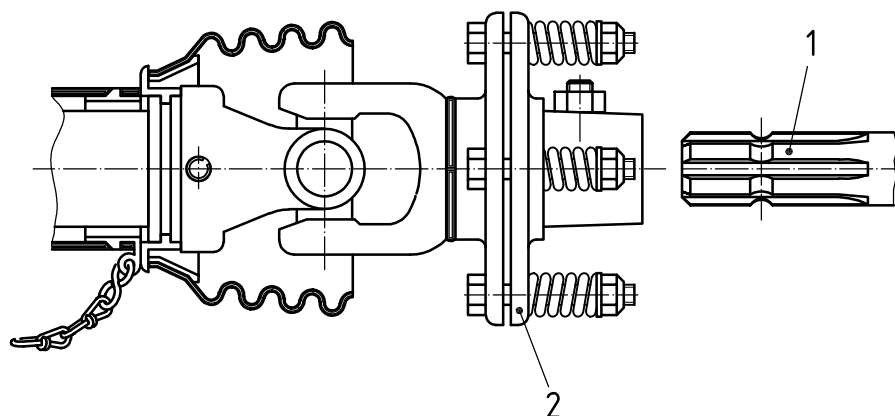
**Key**

- 1 PIC
- 2 torque limiter

Figure 4 — Example of torque limiter
(standards.iteh.ai)

3.9**non-rotating PTO drive shaft guard**

PTO drive shaft guard attached to the shaft by bearings, designed to be able to be held stationary by a restraining system while the shaft is rotating

3.10**PIC [SPTO] [SPIC] guard**

guard, fixed on the implement, which fully covers the PIC, SPTO and SPIC

3.11**restraining system**

part of the PTO drive shaft guard which prevents rotation of the guard when the PTO drive shaft rotates

See Figure 5.

3.12**rotating PTO drive shaft guard**

PTO drive shaft guard attached to the shaft by bearings, designed to be able to rotate with the shaft except when it comes into contact with some other object

3.13**maximum static torsional load**

static load limit without damage or permanent deformation of components

3.14**maximum dynamic torsional load**

dynamic load limit without damage or permanent deformation of components