



SLOVENSKI STANDARD

SIST EN 1075:2000

01-april-2000

Lesene konstrukcije - Metode preskušanja - Spoji s kovinskimi ježastimi ploščami

Timber structures - Test methods - Joints made with punched metal plate fasteners

Holzbauwerke - Prüfverfahren - Verbindungen mit Nagelplatten

Structures en bois - Méthodes d'essai - Assemblages réalisés avec des connecteurs métalliques à plaque emboutie

(standards.iteh.ai)

Ta slovenski standard je istoveten z: **EN 1075:1999**

<https://standards.iteh.ai/catalog/standards/sist/95ed3e08-6b98-47a0-9b00-da04405e9dd5/sist-en-1075-2000>

ICS:

91.080.20 Lesene konstrukcije Timber structures

SIST EN 1075:2000

en

iTeh STANDARD PREVIEW
(standards.iteh.ai)

SIST EN 1075:2000

<https://standards.iteh.ai/catalog/standards/sist/95ed3e08-6b98-47a0-9b00-da04405e9dd5/sist-en-1075-2000>

EUROPEAN STANDARD
NORME EUROPÉENNE
EUROPÄISCHE NORM

EN 1075

September 1999

ICS 91.080.20

English version

Timber structures - Test methods - Joints made with punched metal plate fasteners

Structures en bois - Méthodes d'essai - Assemblages réalisés avec des connecteurs métalliques à plaque emboutie

Holzbauwerke - Prüfverfahren - Verbindungen mit Nagelplatten

This European Standard was approved by CEN on 21 August 1999.

CEN members are bound to comply with the CEN/CENELEC Internal Regulations which stipulate the conditions for giving this European Standard the status of a national standard without any alteration. Up-to-date lists and bibliographical references concerning such national standards may be obtained on application to the Central Secretariat or to any CEN member.

This European Standard exists in three official versions (English, French, German). A version in any other language made by translation under the responsibility of a CEN member into its own language and notified to the Central Secretariat has the same status as the official versions.

CEN members are the national standards bodies of Austria, Belgium, Czech Republic, Denmark, Finland, France, Germany, Greece, Iceland, Ireland, Italy, Luxembourg, Netherlands, Norway, Portugal, Spain, Sweden, Switzerland and United Kingdom.

[SIST EN 1075:2000](https://standards.iteh.ai/catalog/standards/sist/95ed3e08-6b98-47a0-9b00-da04405e9dd5/sist-en-1075-2000)

<https://standards.iteh.ai/catalog/standards/sist/95ed3e08-6b98-47a0-9b00-da04405e9dd5/sist-en-1075-2000>



EUROPEAN COMMITTEE FOR STANDARDIZATION
COMITÉ EUROPÉEN DE NORMALISATION
EUROPÄISCHES KOMITEE FÜR NORMUNG

Central Secretariat: rue de Stassart, 36 B-1050 Brussels

Contents:

	Page
Foreword.....	3
1 Scope	3
2 Normative references.....	3
3 Definitions.....	4
4 Symbols	4
5 Materials.....	6
5.1 Timber	6
5.2 Fasteners.....	6
6 Test methods.....	6
6.1 General	6
6.2 Conditioning	6
6.3 Fabrication of test pieces.....	7
6.4 Preparation of test pieces.....	7
6.5 Procedure.....	10
6.6 Expression of results	11
6.7 Test report.....	13
Annex A (normative) Nail root test.....	14
Annex B (Informative) Derivation of rotational stiffness of the contact surface of the fastener and timber	16
Annex C (Informative) Examples of properly located transducers.....	18
Annex D (Informative) Examples of loading arrangement	19

iTech STANDARD PREVIEW
(standards.itech.ai)

SIST EN 1075:2000

Derivation of rotational stiffness of the contact surface of the fastener and timber
da04405e9dd5/sist-en-1075-2000

Foreword

This European Standard has been prepared by Technical Committee CEN/TC 124 "Timber structures", the secretariat of which is held by DS.

This European Standard shall be given the status of a national standard, either by publication of an identical text or by endorsement, at the latest by March 2000, and conflicting national standards shall be withdrawn at the latest by March 2000.

According to the CEN/CENELEC Internal Regulations, the national standards organizations of the following countries are bound to implement this European Standard: Austria, Belgium, Czech Republic, Denmark, Finland, France, Germany, Greece, Iceland, Ireland, Italy, Luxembourg, Netherlands, Norway, Portugal, Spain, Sweden, Switzerland and the United Kingdom.

This Standard is one of a series of standards for test methods for building materials and components. It was prepared by a working group under the convenorship of National Standards Authority of Ireland, (NSAI).

The standard includes a normative annex giving a method for the testing of nail root in alternate bending and three informative annexes dealing respectively with 1) the derivation of the rotational stiffness of the contact surface of the fastener and timber; 2) examples of properly located transducers and 3) examples of loading arrangement for fastener shear capacity determination.

1 Scope

iTeh STANDARD PREVIEW

(standards.iteh.ai)

This European Standard specifies the test methods for determining the strength capacity and stiffness of joints made with punched metal plate fasteners in load bearing timber structures, being used to join two or more pieces of timber of the same thickness in the same plane. The properties measured are

[https://standards.iteh.ai/catalog/standards/sist/95ed3e08-6b98-47a0-9b00-](https://standards.iteh.ai/catalog/standards/sist/95ed3e08-6b98-47a0-9b00-100495601105/EN-1075-1999)

- load-slip characteristics and maximum load resulting from the lateral resistance of the embedded projections, at various angles between the direction of the applied force and

the axis of the fastener (load-fastener angle α)

the direction of the grain of the timber (load-grain angle β)

- the tension capacity of the fastener at various angles α
- the compression capacity of the fastener at various angles α
- the shear capacity of the fastener at various angles α .

A nail root test method is shown in Annex A.

2 Normative references

This European Standard incorporates by dated or undated reference, provisions from other publications. These normative references are cited at the appropriate places in the text and the publications are listed hereafter. For dated references, subsequent amendments to or revisions of any of these publications apply to this European Standard only when incorporated in it by amendment or revision. For undated references the latest edition of the publication referred to applies.

- EN 26891 Timber structures - Joints made with mechanical fasteners - General principles for the determination of strength and deformation characteristics
- EN 28970 Timber structures - Testing of joints made with mechanical fasteners - Requirements for wood density.

3 Definitions

For the purposes of this standard, the following definitions apply.

3.1 punched metal plate fastener: Fastener made of metal plate of nominal thickness not less than 0,9 mm and not more than 2,5 mm, having integral projections punched out in one direction and bent perpendicular to the base of the metal plate.

3.2 major axis of fastener: Direction giving the highest tension capacity per unit width of the fastener. (In many cases the punching pattern of the fastener gives rise to two main directions, perpendicular to each other, with different capacity properties).

3.3 effective area of fastener: The contact area of fastener and timber member reduced by 5 mm from the edges and by 10 mm in the grain direction from the end of the timber member, see figure 1.

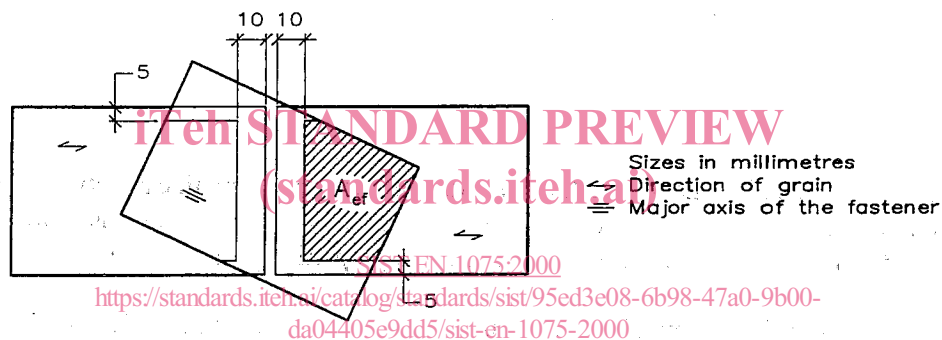

Figure 1: Definition of effective area of fastener

3.4 anchorage capacity per unit area: The maximum load resisted by the joint per effective unit area of the fastener.

3.5 characteristic density: the population 5-percentile value with the mass and volume corresponding to equilibrium moisture content at a temperature of 20 °C and a relative humidity of 65 %.

3.6 design core thickness of fastener: nominal thickness of the fastener, reduced by the thickness of the coating and further reduced by the minus tolerance of the core thickness.

4 Symbols

- A_{ef} effective area of fastener, in square millimetres
- b width of fastener perpendicular to the major axis of the fastener, in millimetres
- $f_{a,\alpha,\beta}$ fastener anchorage capacity, in newtons per square millimetre
- $f_{c,\alpha}$ fastener compression capacity, in newtons per millimetre

$f_{t,\alpha}$	fastener tension capacity, in newtons per millimetre
$f_{t,act}$	actual tension strength of the fastener material, in newtons per square millimetre
$f_{t,k}$	characteristic tension strength of the fastener material, in newtons per square millimetre
$f_{v,\alpha}$	fastener shear capacity, in newtons per millimetre
$f_{y,act}$	actual yield stress of the fastener material in newtons per square millimetre
$f_{y,k}$	characteristic yield stress of the fastener material in newtons per square millimetre
F	load, in newtons
F_{max}	maximum load, in newtons
$F_{max,est}$	estimated maximum load, in newtons
h	depth of timber, in millimetres
l	length of fastener parallel to the major axis of the fastener, in millimetres
l_1, l_2	lengths of area covered by the fastener (see figure 3), in millimetres
l_j	length of the fastener in the joint line, in millimetres
t	thickness of timber test piece, in millimetres
$t_{cor,d}$	design core thickness of fastener, in millimetres https://standards.iteh.ai/catalog/standards/sist/95ed3e08-6b98-47a0-9b00-3b1405c31d1d/en-1075-2000
t_{act}	actual core thickness of fastener, in millimetres
α	angle between the direction of the applied force and the major axis of the fastener, in degrees
β	angle between the direction of the applied force and the direction of the grain of the timber, in degrees
θ	angle between the gap line and the line through the load point and the centre point of the fastener (see figure 6), in degrees,
ρ	density of the timber member in which the failure took place, in kilogrammes per cubic metre.
ρ_k	characteristic density of the timber or timber grade, to which the test results shall be applied, in kilogrammes per cubic metre.

5 Materials

5.1 Timber

The timber shall be selected in accordance with either of the methods given in EN 28970 (see also 6.6.1).

5.2 Fasteners

The fastener specification, including the relevant characteristic mechanical properties (e.g., tensile strength, yield stress and elongation) of the steel used to manufacture the fasteners, determined using standard test procedures, shall be recorded. For the purpose of verifying such records, material shall be available which has been taken from the coil used in the manufacture of the fasteners.

The ductility of the fasteners at the root position of the projections shall be determined in accordance with annex A.

NOTE: The sizes (length and width) of fastener to be used for the various tests should be selected in such a way that capacity values for the complete range of sizes normally produced by the fastener manufacturer may be obtained by interpolation or extrapolation with adequate reliability.

6 Test methods

6.1 General

For the determination of the fastener tension capacity, the timber shall be sufficiently strong for failure to occur in the fastener. The timber used shall have a target size, see EN 336, of not less than 35 mm or twice the length of the projections plus 5 mm, whichever is the greater.

NOTE 1: In the tests specified in 6.4.1 and 6.4.2 the minimum timber thickness should be limited to that proposed for use in service.

<https://standards.iteh.ai/catalog/standards/sist/95ed3e08-6b98-47a0-9b00->

NOTE 2: Test data of anchorage capacity should not be applied to joints with members thinner than those tested, but may be applied to joints with thicker members.

NOTE 3: Examples of properly located transducers are given in Annex C (Informative).

If there are no special requirements, the timber shall be planed; the difference in thickness between adjoining pieces shall not exceed 0,5 mm. For each test piece, the two individual members to be joined shall be cut from adjacent positions on the same plank to ensure a test piece of balanced density. In each group of similar test pieces, the timber for each test piece shall be cut from a different plank.

Timber members for the test pieces shall be cut so that the areas to which the fasteners are embedded are free from knots, local grain disturbance, fissures and wane. Elsewhere the members shall be free from characteristics which could lead to premature failure in the timber.

The moisture content of the timber and its density shall be determined.

6.2 Conditioning

The test pieces shall be manufactured with the timber at an equilibrium moisture content corresponding to (20 ± 2) °C and (85 ± 5) % relative humidity and shall afterwards be conditioned for at least one week at (20 ± 2) °C and (65 ± 5) % relative humidity. The timber material is conditioned when it attains constant mass. Constant mass is considered to be attained when the results of two successive weighings, carried out at an interval of 6 h, do not differ by more than 0,1 % of the mass of the timber material. For certain investigations other moisture conditioning may be appropriate, and shall be reported.

NOTE: For some hardwoods a much longer conditioning period may be necessary.

6.3 Fabrication of test pieces

Test pieces shall be made with two fasteners positioned parallel to each other and symmetrically on opposite faces of the joint. The size and geometry of the test pieces will depend upon fastener size and the property being measured. The test pieces shall be assembled using the method (e.g. press or roller) normally used with the particular fasteners in the commercial production of structural timber components and the projections of the fastener shall be fully embedded in the timber so that the contact surface of the fastener is flush with the surface of the timber. If complementary nails are used to locate fasteners during the assembly of joints, such nails shall either be omitted from the test pieces or withdrawn prior to the test. The fasteners shall not be modified by the removal of any projections or by notching.

In the case of the testing of fastener compression capacity (see 6.4.4), the test piece shall be fabricated so that the pieces of timber in the test piece are separated by a gap of not less than 4 mm.

In the case of the other test series, the test piece shall be fabricated so that the pieces of timber in the test piece are separated by a gap of not less than 2 mm.

NOTE: The fastener size should be chosen so that no anchorage failure occurs in the determination of the tension, compression and shear capacity of the fastener. However, in testing for shear capacity, some buckling of the edge of the fastener may occur locally and this should be acceptable.

6.4 Preparation of test pieces

6.4.1 Anchorage capacity and load-slip characteristics of contact surface of fastener and timber: load parallel to grain The maximum load due to the lateral resistance of the fastener projections and the load-slip characteristics, with the load applied in the direction parallel to the grain of the timber, shall be determined using the test piece shown in figure 2.

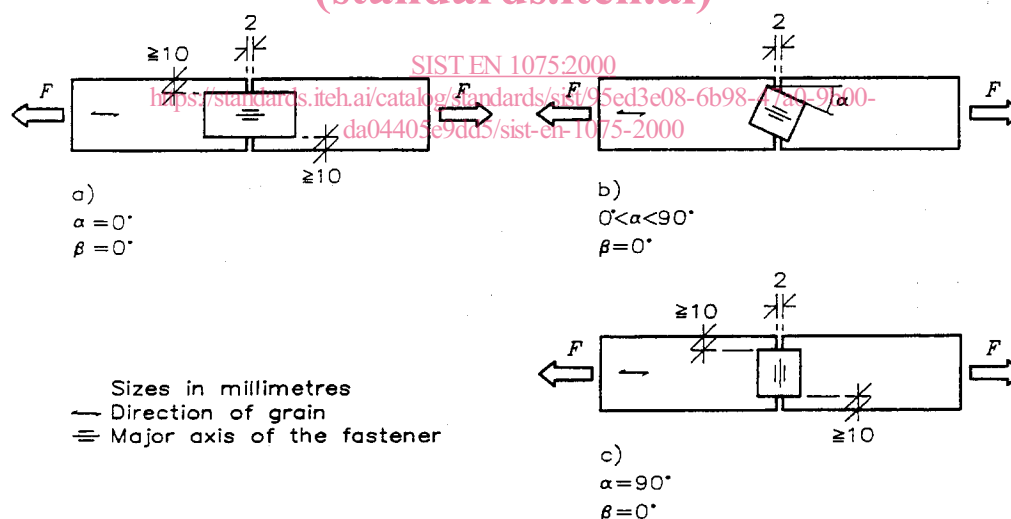

Figure 2: Test piece for anchorage capacity and load-slip characteristics of contact surface: load parallel to grain.

The length of the test piece shall be such that the ends of the test machine grips shall be not less than 200 mm from the ends of the fasteners. Where necessary, the ends of the test piece may be reinforced to avoid premature failure at the grips.

Generally fasteners have multiple projections in a modular arrangement and it will be sufficient to test one size of fastener at each value of the angle α . The size of the fastener shall be such that its dimension in the direction of the applied force is the largest for which failure at the embedded projections will occur.

NOTE: The selection of the appropriate size of fastener may often be made on the basis of experience with similar fasteners. However, preliminary tests may sometimes be required.

The fasteners shall be positioned on the members so as to minimise the effects of moment rotation. The corners of the fastener may cross the edges of timber members.

NOTE: With the results of the anchorage test and the shear test, the rotational stiffness of the contact surface of the fastener with the timber at various angles α may be derived by calculation as shown in annex B.

6.4.2 Anchorage capacity and load-slip characteristics of contact surface of fastener and timber: load not parallel to grain The maximum load due to the lateral resistance of the fastener projections and the load-slip characteristics, with the load applied other than parallel to the grain of the timber, shall be determined using the test piece shown in figure 3.

The length of the abutting timber loaded in tension shall be such that the end of the test machine grip shall be not less than 20 mm from the ends of the fasteners.

NOTE: The distance between the edge of the fastener and the edge of the support should be in the range $\frac{h}{4}$ to h .

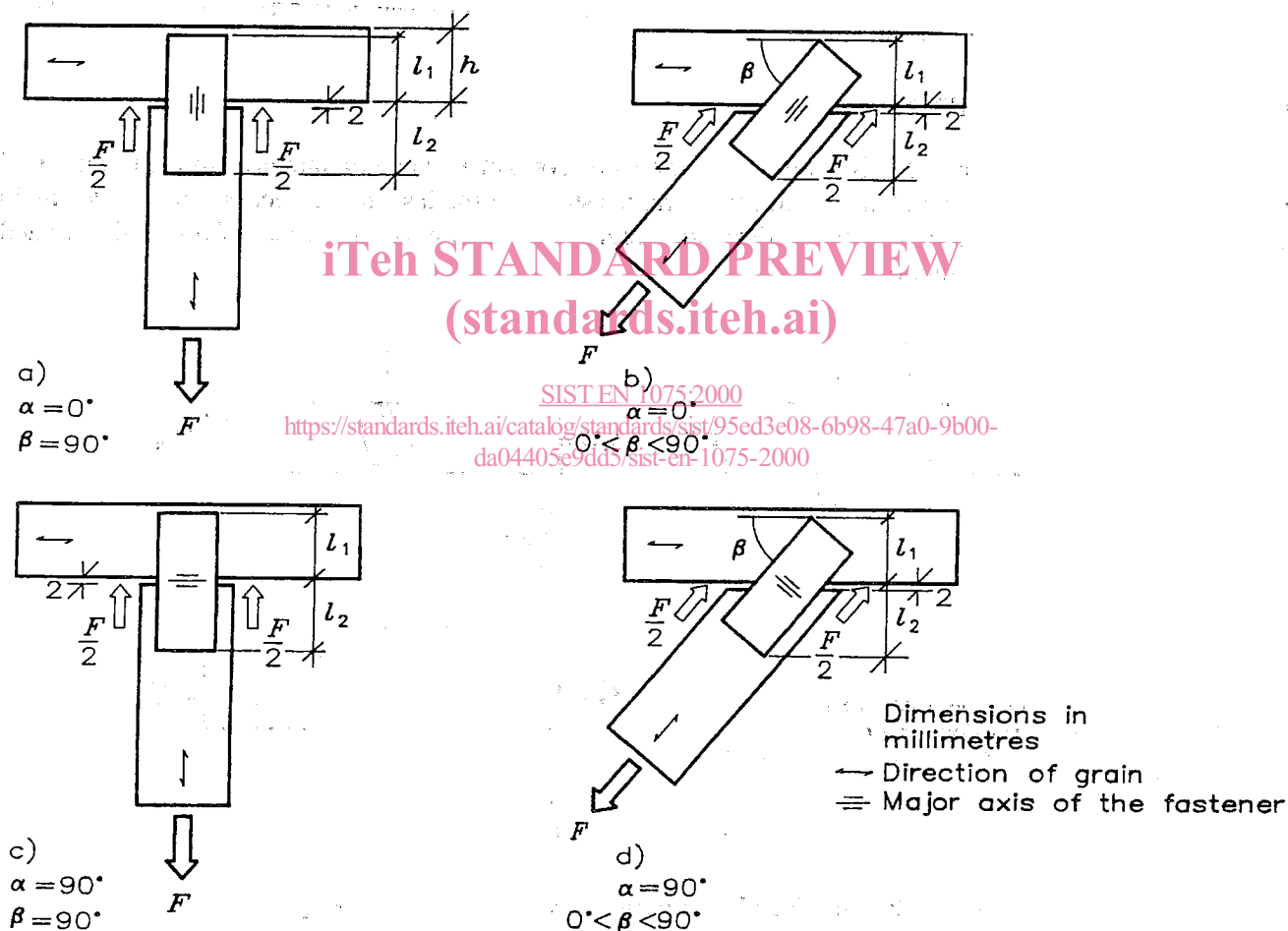

Figure 3: Test piece for anchorage capacity and load-slip characteristics of contact surface: load not parallel to grain.

The fasteners shall be positioned to favour failure at the fastener projections embedded in the member loaded not parallel to the grain of the member, i.e. in the cross member. This will normally occur when $l_1 < l_2$ and $l_1 \geq 0,7 h$.

NOTE: The selection of the appropriate size of fastener may be made on the basis of experience with similar fasteners. However, preliminary tests may sometimes be required.

6.4.3 Fastener tension capacity Fastener tension capacity shall be determined using the test piece shown in figure 4.

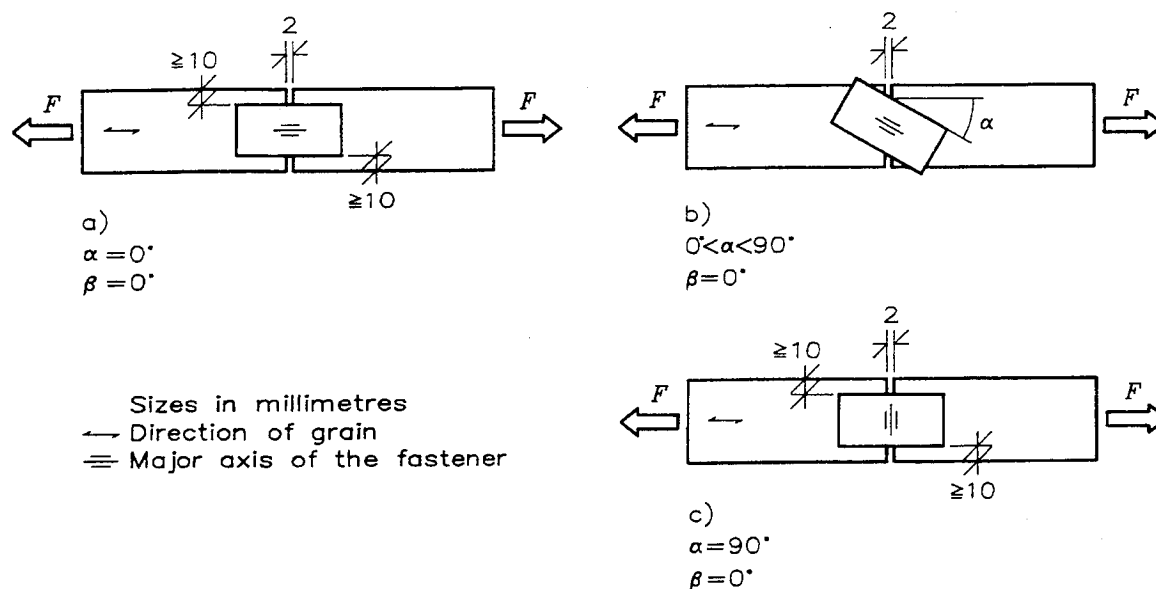

Figure 4: Test piece for fastener tension capacity.

The length of the fastener and the cross-section dimensions of the timber shall be chosen on the basis of the results found from testing the test pieces described in 6.4.1 to ensure that failure occurs in the fastener. The weakest cross-section near the fastener centreline shall be over the gap between the timber members of the joint.

SIST EN 1075:2000

6.4.4 Fastener compression capacity Fastener compression capacity shall be determined using the test piece shown in figure 5.

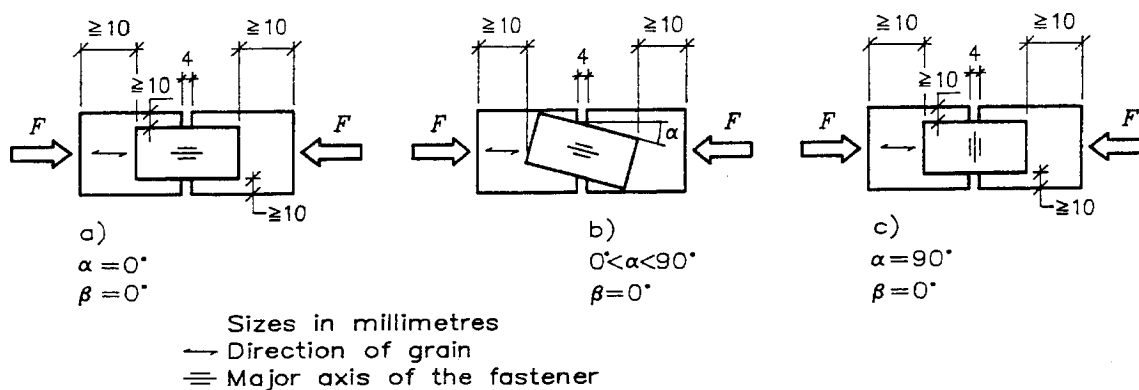

Figure 5: Test piece for fastener compression capacity.

The length of the fastener and the cross-section dimensions of the timber shall be chosen on the basis of the results found from testing the test pieces described in 6.4.1 to ensure that failure occurs in the fastener. The weakest cross-section near the fastener centreline shall be over the gap between the timber members of the joint.