

INTERNATIONAL STANDARD

ISO
45

Second edition
1990-12-01

Aircraft — Pressure refuelling connections

Aéronefs — Raccords de remplissage sous pression en combustible

iTeh Standards
(<https://standards.itih.ai>)
Document Preview

[ISO 45:1990](#)

<https://standards.itih.ai/catalog/standards/iso/6bab3fb-9802-4dcb-997e-74cca6d82d6/iso-45-1990>



Reference number
ISO 45:1990(E)

Foreword

ISO (the International Organization for Standardization) is a worldwide federation of national standards bodies (ISO member bodies). The work of preparing International Standards is normally carried out through ISO technical committees. Each member body interested in a subject for which a technical committee has been established has the right to be represented on that committee. International organizations, governmental and non-governmental, in liaison with ISO, also take part in the work. ISO collaborates closely with the International Electrotechnical Commission (IEC) on all matters of electrotechnical standardization.

Draft International Standards adopted by the technical committees are circulated to the member bodies for voting. Publication as an International Standard requires approval by at least 75 % of the member bodies casting a vote.

International Standard ISO 45 was prepared by Technical Committee ISO/TC 20, *Aircraft and space vehicles*.

This second edition cancels and replaces the first edition (ISO 45:1980), of which it constitutes a minor revision.

ISO 45:1990

<https://standards.iteh.ai/catalog/standards/iso/6bab3fb-9802-4dcb-997c-74cea6d82ef6/iso-45-1990>

© ISO 1990

All rights reserved. No part of this publication may be reproduced or utilized in any form or by any means, electronic or mechanical, including photocopying and microfilm, without permission in writing from the publisher.

International Organization for Standardization
Case Postale 56 • CH-1211 Genève 20 • Switzerland

Printed in Switzerland

Aircraft — Pressure refuelling connections

1 Scope

This International Standard specifies the basic dimensions and access clearance for aircraft pressure refuelling connections.

2 Requirements

2.1 Basic dimensions

The basic dimensions for aircraft pressure refuelling connections shall be in accordance with those shown in figure 1 and given in table 1.

2.2 Access clearance

The clearance allowed around the connector shall be in accordance with figure 2.

iTeh Standards

(<https://standards.itih.ai>)
Document Preview

ISO 45:1990

<https://standards.itih.ai/catalog/standards/iso/6bab3fb-9802-4dcb-997c-74cea6d82ef6/iso-45-1990>

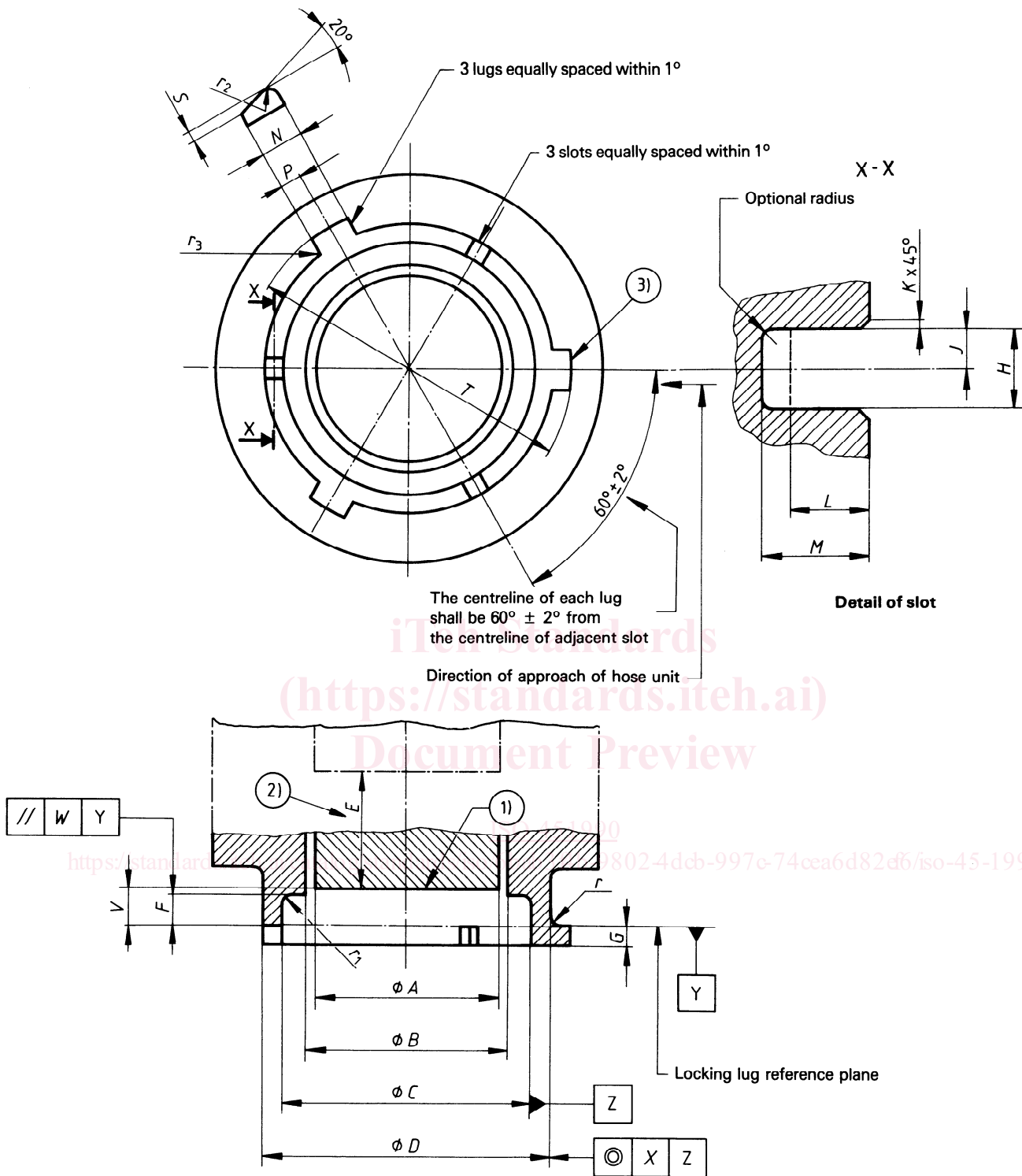

NOTES

- 1 The valve face shall be flat within diameter A and no part of the valve shall extend below this face. Configuration of the valve above this face is optional.
 - 2 The valve is spring-loaded. Loading at 36,52 mm (1,438 in) travel shall not exceed 222 N (50 lbf).
 - 3 When the connection is in an overhead horizontal surface (for example under the wing) one bayonet lug shall be centrally located towards the normal approach of the operator for the refuelling.
- Except where the aircraft connection is mounted on a horizontal surface, one of the three lugs shall be centrally located at the lowest point of the connection.

Figure 1 — Pressure refuelling connections