



SLOVENSKI STANDARD
SIST EN 1858:2009+A1:2011

01-oktober-2011

Nadomešča:
SIST EN 1858:2009

Dimniki - Sestavni deli - Betonski bloki za dimnike

Chimneys - Components - Concrete flue blocks

Abgasanlagen - Bauteile - Betonformblöcke

Conduits de fumée - Composants - Conduits de fumée simple et multiparois en béton

iTeh STANDARD PREVIEW
(standards.iteh.ai)

Ta slovenski standard je istoveten z: EN 1858:2008+A1:2011

<https://standards.iteh.ai/catalog/standards/sist/9d0198aa-e197-49b6-a32b-e485b8d74ded/sist-en-1858-2009a1-2011>

ICS:

91.060.40	Dimniki, jaški, kanali	Chimneys, shafts, ducts
91.100.30	Beton in betonski izdelki	Concrete and concrete products

SIST EN 1858:2009+A1:2011

en,fr,de

iTeh STANDARD PREVIEW
(standards.iteh.ai)

SIST EN 1858:2009+A1:2011

<https://standards.iteh.ai/catalog/standards/sist/9d0198aa-e197-49b6-a32b-c485b8d74ded/sist-en-1858-2009a1-2011>

EUROPEAN STANDARD

EN 1858:2008+A1

NORME EUROPÉENNE

EUROPÄISCHE NORM

June 2011

ICS 91.060.40; 91.100.30

Supersedes EN 1858:2008

English Version

Chimneys - Components - Concrete flue blocksConduits de fumée - Composants - Conduits de fumée
simple et multiparois en béton

Abgasanlagen - Bauteile - Betonformblöcke

This European Standard was approved by CEN on 1 November 2008 and includes Amendment 1 approved by CEN on 14 May 2011.

CEN members are bound to comply with the CEN/CENELEC Internal Regulations which stipulate the conditions for giving this European Standard the status of a national standard without any alteration. Up-to-date lists and bibliographical references concerning such national standards may be obtained on application to the CEN-CENELEC Management Centre or to any CEN member.

This European Standard exists in three official versions (English, French, German). A version in any other language made by translation under the responsibility of a CEN member into its own language and notified to the CEN-CENELEC Management Centre has the same status as the official versions.

CEN members are the national standards bodies of Austria, Belgium, Bulgaria, Croatia, Cyprus, Czech Republic, Denmark, Estonia, Finland, France, Germany, Greece, Hungary, Iceland, Ireland, Italy, Latvia, Lithuania, Luxembourg, Malta, Netherlands, Norway, Poland, Portugal, Romania, Slovakia, Slovenia, Spain, Sweden, Switzerland and United Kingdom.

[SIST EN 1858:2009+A1:2011](https://standards.iteh.ai/catalog/standards/sist/9d0198aa-e197-49b6-a32b-c485b8d74ded/sist-en-1858-2009a1-2011)

<https://standards.iteh.ai/catalog/standards/sist/9d0198aa-e197-49b6-a32b-c485b8d74ded/sist-en-1858-2009a1-2011>



EUROPEAN COMMITTEE FOR STANDARDIZATION
COMITÉ EUROPÉEN DE NORMALISATION
EUROPÄISCHES KOMITEE FÜR NORMUNG

Management Centre: Avenue Marnix 17, B-1000 Brussels

Contents

	Page
Foreword.....	4
1 Scope	5
2 Normative references	5
3 Terms and definitions	5
4 Materials	7
4.1 General.....	7
4.2 Reaction to fire.....	7
5 Reinforcement for handling.....	8
6 Surface treatment	8
7 Form, dimensions and tolerances	8
7.1 Form.....	8
7.2 Type B flue blocks	8
7.3 Tolerances	9
7.4 Straightness	10
7.5 Squareness of ends.....	10
8 Performance.....	10
8.1 Heat stress resistance.....	10
8.2 Heat shock resistance.....	10
8.3 Thermal resistance	11
8.4 Gas tightness	11
8.5 Abrasion resistance.....	12
8.6 Compressive strength.....	12
8.7 Corrosion resistance.....	12
8.8 Condensate resistance	13
8.9 Bulk density.....	13
8.10 Flexural strength under wind loading	13
8.11 Flow resistance.....	13
8.12 Freeze-thaw resistance	14
8.13 Resistance to fire external to external.....	14
8.14 Dangerous substances	14
9 Designation	14
9.1 General.....	14
9.2 Temperature class	15
9.3 Pressure class.....	15
9.4 Resistance to fire class.....	16
9.5 Resistance to condensate class	16
9.6 Corrosion resistance class.....	16
10 Marking	17
11 Product information.....	17
12 Evaluation of conformity.....	17
12.1 General.....	17
12.2 Initial type testing	18
12.3 Further type tests.....	18
12.4 Factory production control.....	18
Annex A (normative) Test methods	19



iTech STANDARD PREVIEW
(standards.iteh.ai)

[SIST EN 1858:2009+A1:2011](https://standards.iteh.ai/catalog/standards/sist/9d0196aa-c197-49b6-a52b-c485b8d74ded/sist-en-1858-2009a1-2011)

<https://standards.iteh.ai/catalog/standards/sist/9d0196aa-c197-49b6-a52b-c485b8d74ded/sist-en-1858-2009a1-2011>

A.1	Squareness of ends test.....	19
A.2	Straightness test	21
A.3	Heat stress resistance and heat shock test.....	22
A.4	Thermal resistance	27
A.5	Gas tightness test	29
A.6	Abrasion resistance test.....	31
A.7	Compressive strength test	32
A.8	Corrosion and condensate resistance test.....	33
A.9	Flexural strength under wind load.....	36
A.10	Bulk density	37
A.11	Ultimate compressive strength.....	38
Annex B (informative) Examples of concrete flue block shapes		39
B.1	Straight flue blocks	39
B.2	Flue block fittings - Tee/access/connection unit	40
B.3	Examples of Type B flue block shapes	41
Annex C (normative) Thermal resistance calculation method		43
C.1	Thermal resistance of the individual element	43
C.2	Thermal resistance of the chimney and of enclosures	43
Annex D (normative) Requirements of sampling plan according to ISO 2859-1:1999 at an Acceptable Quality Level (AQL) of 10 % and inspection level S2		44
D.1	Acceptability determination	44
D.2	Normal inspection	44
D.3	Reduced Inspection	46
D.4	Reduced to normal inspection.....	47
D.5	Tightened inspection.....	47
D.6	Tightened to normal inspection.....	47
D.7	Discontinuation of inspection.....	47
Annex E (informative) Recommended test sequence		48
Annex ZA (informative) Clauses of this European standard addressing the provisions of the EU Construction Products Directive		49
ZA.1	Relationship between EU Directives and this European Standard	49
ZA.2	Procedure of attestation of conformity of concrete flue blocks.....	51
ZA.3	CE Marking and labelling	52
Bibliography.....		55

EN 1858:2008+A1:2011 (E)**Foreword**

This document (EN 1858:2008+A1:2011) has been prepared by Technical Committee CEN/TC 166 “Chimneys”, the secretariat of which is held by  ASI .

This European Standard shall be given the status of a national standard, either by publication of an identical text or by endorsement, at the latest by December 2011, and conflicting national standards shall be withdrawn at the latest by March 2013.

Attention is drawn to the possibility that some of the elements of this document may be the subject of patent rights. CEN [and/or CENELEC] shall not be held responsible for identifying any or all such patent rights.

For the relationship with the EU Directives, see informative Annex ZA, which is an integral part of this standard.

In this European Standard, the Annexes A, C and D are normative (not forming part of the product specification) and Annexes E and ZA are informative.

This document includes Amendment 1 approved by CEN on 14 May 2011.

The start and finish of text introduced or altered by amendment is indicated in the text by tags  .

This document supersedes  EN 1858:2008 .

This Standard is one of a series of co-ordinated standards dealing with specification, design, testing and installation of chimneys, both single and multi wall.

The co-ordinated package of standards is further divided by material of construction and this European Standard is one of a series of specifications and execution documents dealing with design and installation of concrete chimney products and systems.

The standards in this series for concrete chimney products and systems are:

EN 1857, *Chimneys — Components — Concrete flue liners*;

EN 1858, *Chimneys — Components — Concrete flue blocks*;

EN 12446, *Chimneys — Components — Concrete outer wall elements*.

According to the CEN/CENELEC Internal Regulations, the national standards organizations of the following countries are bound to implement this European Standard: Austria, Belgium, Bulgaria, Croatia, Cyprus, Czech Republic, Denmark, Estonia, Finland, France, Germany, Greece, Hungary, Iceland, Ireland, Italy, Latvia, Lithuania, Luxembourg, Malta, Netherlands, Norway, Poland, Portugal, Romania, Slovakia, Slovenia, Spain, Sweden, Switzerland and the United Kingdom.

1 Scope

This European Standard specifies the materials, dimensional and performance requirements for precast concrete flue blocks as defined in Clause 3 for use in ~~EN~~ ^{A1} chimneys. The flue blocks may be of single wall or multi wall construction. The standard does not apply to flue blocks with back ventilation.

This standard does not cover products designated wet (W) in conjunction with corrosion class 3.

The standard also specifies a type of flue block to dimensionally co-ordinate with masonry unit coursing height, referred to as a type B (Bonding block).

This European Standard also applies to storey-height and flue blocks reinforced for handling.

NOTE Any reference to the term flue blocks implies both flue blocks and their fittings, except where otherwise indicated.

2 Normative references

The following referenced documents are indispensable for the application of this document. For dated references, only the edition cited applies. For undated references, the latest edition of the referenced document (including any amendments) applies.

EN 206-1: 2000, *Concrete — Part 1: Specification, performance, production and conformity*

EN 1443, *Chimneys — General requirements*

EN 10088-2, *Stainless steel — Part 2: Technical delivery conditions for sheet/plate and strip of corrosion resisting steels for general purposes*

EN 13216-1, *Chimneys — Test methods for system chimneys — Part 1: General test methods*

EN 13384-1, *Chimneys — Thermal and fluid dynamic calculation methods — Part 1: Chimneys serving one appliance*

EN 14297: 2004, *Chimneys — Freeze-thaw resistance test method for chimney products*

EN ISO 7500-1:2004, *Metallic materials — Verification of static uniaxial testing machines — Part 1: Tension/compression testing machines* ^{A1} (ISO 7500-1:2004) ^{A1}

ISO 2859-1:1999, *Sampling procedures for inspection by attributes — Part 1: Sampling schemes indexed by acceptance quality limit (AQL) for lot-by-lot inspection*

3 Terms and definitions

For the purposes of this European Standard, the terms and definitions given in EN 1443 and the following apply.

3.1

flue block fitting

element fitted to the flue block such as an access opening or offset

EN 1858:2008+A1:2011 (E)

3.2

hollow wall flue block

flue block having vertical cavities

NOTE Cavities may pass through both ends of the block.

3.3

manufacturer's declared internal transverse dimension

internal dimension of the flue block measured perpendicular to the longitudinal axis

3.4

manufacturer's declared height

internal height of the flue block

NOTE Examples of measurement are shown in Figure 1.

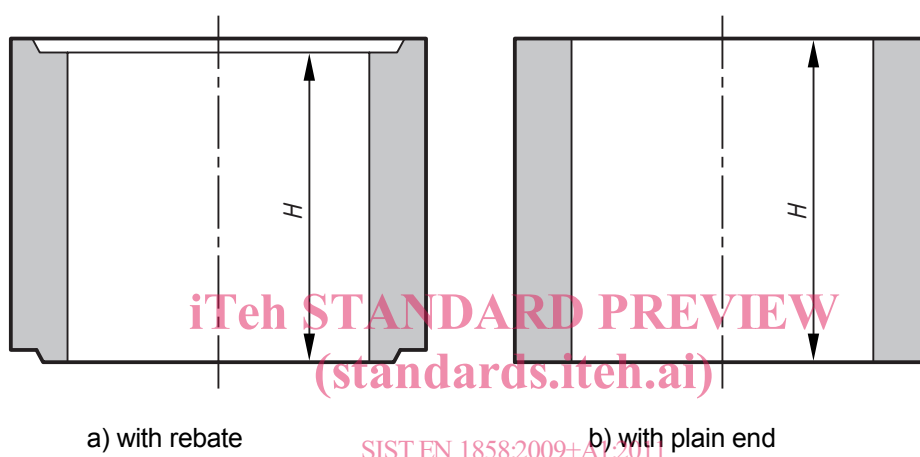

a) with rebate

b) with plain end

Key

H internal height

<https://standards.iteh.ai/catalog/standards/sist/9d0198aa-e197-49b6-a32b-c485b8d74ded/sist-en-1858-2009a1-2011>

Figure 1 — Manufacturer's declared height

3.5

manufacturer's declared structural height

maximum constructional height of the flue blocks as declared by the manufacturer

3.6

manufacturer's declared overall wall thickness

dimensions at its thinnest point, between the inside face of the flue and the outside face of the flue block, not measured at any joint feature, e.g. spigot/socket end

3.7

multi wall flue block

flue block consisting of a flue liner and at least one additional wall

3.8

reinforced flue block

flue block having reinforcement to assist handling (not for structural stability)

3.9

solid wall flue block

flue block without cavities in the thickness of its walls

3.10**straight flue block**

flue block designed to be used in a vertical section of a chimney, without having any special characteristics and having the ends perpendicular to the axis of the flue

3.11**storey-height flue block**

factory made flue block having an overall height relating to the floor to floor height of a building

3.12**transfer block**

flue block designed to facilitate connection to another chimney product

3.13**concrete**

material formed by mixing cement, aggregate and water and with or without the incorporation of admixtures or additions, which develops its properties by hydration of the cement

[EN 206-1:2000]

3.14**precast concrete**

concrete that is cast in a place other than its final location of use

3.15**type B flue block****type B (Bonding) block**

bonding block dimensionally co-ordinated with masonry unit coursing height, and having a designation T250, N, D1, O xx (see Clause 9).

iTeh STANDARD PREVIEW
(standards.iteh.ai)

[SIST EN 1858:2009+A1:2011](https://standards.iteh.ai/catalog/standards/sist/9d0198aa-e197-49b6-a32b-c485b8d74ded/sist-en-1858-2009a1-2011)

<https://standards.iteh.ai/catalog/standards/sist/9d0198aa-e197-49b6-a32b-c485b8d74ded/sist-en-1858-2009a1-2011>

4 Materials**4.1 General**

The wall or walls of flue blocks shall be precast concrete. For multiwall flue blocks the liner and outer wall may be separated by an air space or insulation.

Materials used in the manufacture of flue blocks shall be identified for factory production control purposes.

When insulation forms part of a flue block, it shall be of bonded material as specified by the manufacturer. If the insulation is supplied as a separate item, it shall be installed in accordance with the flue block manufacturer's installation instructions.

The manufacturer shall declare the bulk density of the flue block and when tested to A.10 the density shall be within ± 10 % of the declared value (see 8.9).

4.2 Reaction to fire

In accordance with Commission Decision 96/603/EC, as amended, flue blocks to this standard are classified as reaction to fire class A1 without test provided, they contain not more than a mass or volume fraction of 1 % (whichever is the more onerous) of homogeneously distributed organic materials.

EN 1858:2008+A1:2011 (E)**5 Reinforcement for handling**

5.1 Where a flue block is reinforced for handling, the reinforcement shall have a maximum diameter of 8 mm and a minimum concrete cover of 15 mm on all sides for temperature classes up to and including T250 and a minimum concrete cover of 20 mm on all sides for all other temperature classes.

5.2 In flue blocks having a bulk density of less than 2 000 kg/m³, when measured in accordance with Clause A.10, any reinforcement shall be protected against corrosion by one of the following means:

- a) use of stainless steel;
- b) by completely covering any mild steel reinforcement with a coating (e.g. typically Portland cement CEM I or CEM II mixed with water to form a slurry, or epoxy resin).

6 Surface treatment

Any surface treatment of the flue block, e.g. render, shall be applied, as described by the product manufacturer, before the product is tested.

7 Form, dimensions and tolerances**7.1 Form**

7.1.1 Single wall or multi-wall flue blocks shall be manufactured in one of the following forms:

- a) single flue;
- b) multi-flue;
- c) flue/ventilation combination.

iTeh STANDARD PREVIEW
(standards.iteh.ai)
[SIST EN 1858:2009+A1:2011
https://standards.iteh.ai/catalog/standards/sist/9d0198aa-e197-49b6-a32b-c485b8d74ded/sist-en-1858-2009a1-2011](https://standards.iteh.ai/catalog/standards/sist/9d0198aa-e197-49b6-a32b-c485b8d74ded/sist-en-1858-2009a1-2011)

NOTE See Annex B for examples of typical flue block types.

7.1.2 Flue blocks shall have a maximum of four flues or ventilation passages.

7.2 Type B flue blocks

7.2.1 The co-ordinating height of Type B flue blocks shall be declared by the manufacturer.

NOTE The co-ordinating height is the height of the flue block plus an allowance for jointing so that the flue block will align with one or more specified coursing heights in a brick or block wall. See Figure 2.

7.2.2 When measured perpendicular to the axis of the flue for Type B flue blocks, the minimum dimensions of the flue shall be not less than 90 mm and the cross-sectional flue area shall be not less than 16 500 mm². In transfer blocks, the flue shall taper to a diameter of not less than 125 mm.

7.2.3 The bonding extension on straight bonding Type B flue blocks shall not be less than 75 mm (see Clause B.3).

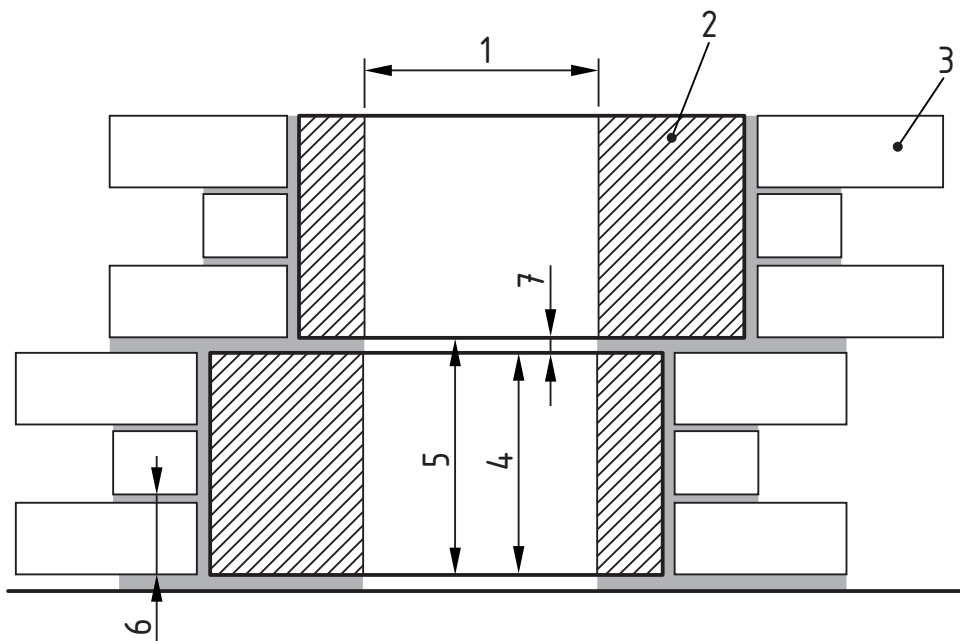
**Key**

- 1 flue
- 2 flue block
- 3 masonry unit
- 4 flue block height
- 5 co-ordinating height
- 6 coursing height
- 7 jointing allowance

iTeh STANDARD PREVIEW
(standards.iteh.ai)

SIST EN 1858:2009+A1:2011

[https://standards.iteh.ai/catalog/standards/sist/9d0198aa-e197-49b6-a32b-](https://standards.iteh.ai/catalog/standards/sist/9d0198aa-e197-49b6-a32b-e487b847464d/sist-en-1858-2009-a1-2011)

Figure 2 — Type B flue blocks jointing with masonry units

7.2.4 The angle of offset in any Type B flue block shall not exceed 30° (see Clause B.3).

7.2.5 Starter Type B flue blocks shall have internal transverse dimensions not less than 305 mm side × 115 mm deep (see Clause B.3).

7.2.6 When jointed together in accordance with the manufacturer's installation instructions, the flue in adjacent Type B flue blocks shall align to within 3 mm.

7.3 Tolerances

Tolerances on manufacturer's declared dimensions, including taper, shall be:

a) Declared internal transverse dimensions

- below 300 mm : ± 3 mm
- 300 mm and above : ± 1,5 %

b) Declared height

- below 300 mm : ± 5 mm
- 300 mm to 700 mm : ± 7 mm
- above 700 mm : ± 10 mm

EN 1858:2008+A1:2011 (E)

c) Declared overall wall thickness

below 10 mm	: +1 -2 mm
10 mm to 40 mm	: +5 -1,5 mm
above 40 mm	: +12 -5 %

7.4 Straightness

7.4.1 When tested as described in A.2, the limit deviation from straightness of a straight concrete flue block of manufacturer's declared height greater than 300 mm and less than 1 000 mm shall not be greater than 1 % of the declared height.

7.4.2 When tested as described in A.2 for flue blocks having a manufactured height equal to or greater than 1 000 mm, the limit deviation shall not be greater than 0,5 % of the manufacturers declared height.

7.5 Squareness of ends

When tested in accordance with either procedure described in A.1, the test sample shall not touch the upright for the first procedure and the dimension G shall not be greater than 5 mm for the second procedure.

iTeh STANDARD PREVIEW (standards.iteh.ai)

8 Performance**8.1 Heat stress resistance**

SIST EN 1858:2009+A1:2011

8.1.1 When flue blocks and fittings, including those designated soot fire resistant, are tested in accordance with A.3 at the test temperature appropriate to the designation specified in Table 1, the flue block shall subsequently meet the requirements of 8.4. In addition, flue blocks and fittings having a compressive strength less than 10 MPa, or having a temperature designation above T250 and/or designated soot fire resistant, shall meet the requirements of 8.5.

When a flue block is multi-flued with an equal wall thickness, the heat stress test shall be carried out on the flue with the highest designation and temperature.

8.1.2 Flue block bends, made of the same material mix and by the same method of manufacture as the tested straight flue block shall be deemed to comply with the requirement in 8.1.1.

8.1.3 Flue block bends and fittings, made of a different material mix or using a different method of manufacture from those described in 8.1.2, shall be checked for heat stress resistance by testing a special straight test sample in accordance with 8.1.1. This straight test sample shall be made using the same material mix and manufacturing method as the bend or fitting.

8.1.4 The distance to combustible material, xx, shall be declared. The maximum temperature measured on the surface of adjacent combustible materials shall not exceed 85 °C when related to an ambient temperature of 20 °C.

8.2 Heat shock resistance

8.2.1 Following the heat stress resistance test in 8.1, when a flue block designated as soot fire resistant is tested as described in A.3 at a flue gas temperature of 1 000 °C for a period of 30 min ± 1 min, the block shall subsequently meet the requirements of 8.4. In addition, flue blocks and fittings having a compressive strength

less than 10 MPa, or having a temperature designation above T250 and/or designated soot fire resistant shall meet the requirements of 8.5.

8.2.2 Flue block bends made of the same material mix and by the same method of manufacture as the tested straight flue block, shall be deemed to comply with the requirement in 8.4.

8.2.3 Flue block bends and fittings, made of a different material mix or using a different method of manufacture from those described in 8.2.1, shall be checked for heat shock by testing a special straight test in accordance with 8.1.1.

8.2.4 The distance to combustible material, xx, shall be declared. The maximum temperature measured on the surface of adjacent combustible materials shall not exceed 100 °C when related to an ambient temperature of 20 °C, when the test assembly is tested at the test temperature of 1 000 °C over a period of 30 min.

Table 1 — Heat stress test temperature

Temperature group	Temperature of flue gas °C
T600	700 ⁺⁵⁰ ₀
T450	550 ⁺⁵⁰ ₀
T400	500 ⁺⁵⁰ ₀
T300	350 ⁺³⁵ ₀
T250	300 ⁺³⁰ ₀
T200	250 ⁺²⁵ ₀
T160	190 ⁺¹⁹ ₀
T140	170 ⁺¹⁷ ₀
T120	150 ⁺¹⁵ ₀
T100	120 ⁺¹² ₀
T080	100 ⁺¹⁰ ₀

8.3 Thermal resistance

Thermal resistance shall be measured in accordance with the method given in A.4 (reference method) or calculated in accordance with the method given in Annex C and the value obtained declared.

8.4 Gas tightness

When tested in accordance with A.5, the gas tightness expressed as a leakage rate of the flue block shall not be greater than the values specified in Table 4 for the relevant gas tightness class before and after the thermal performance tests.

EN 1858:2008+A1:2011 (E)

8.5 Abrasion resistance

All flue blocks having satisfied the gas tightness requirements of 8.4, when tested as described in A.6, the weight of the deposit collected shall not exceed the values in Table 2, and shall subsequently meet the gas tightness requirements of 8.4.

Table 2 — Abrasion resistance

Dry density kg/m ³	Maximum abrasion of inner surface kg/m ²
1 000	1,000
1 100	1,100
1 200	1,200
1 300	1,300
1 400	1,400
1 500	1,500
1 600	1,600
1 700	1,700
1 850	1,850

iTeh STANDARD PREVIEW (standards.iteh.ai)

8.6 Compressive strength

8.6.1 The manufacturer shall declare the structural height. When tested as described in A.7, straight flue blocks and straight fittings shall withstand an intensity of loading equivalent to four times the manufacturer's declared structural height.

<https://standards.iteh.ai/catalog/standards/sist/9d0198aa-e197-49b6-a32b-c485b8d74ded/sist-en-1858-2009a1-2011>

NOTE The manufacturer's declared structural height can be derived from the ultimate compressive strength determined by the method in Clause A.11.

Type B flue blocks shall be tested as a complete element and shall not be cut.

8.6.2 Flue block bends and fittings, made of the same material mix and by the same method of manufacture as the tested straight flue block, shall be deemed to comply with the requirement in 8.6.1.

8.6.3 Flue block bends and fittings, made of a different material mix or using a different method of manufacture from those described in 8.6.2, shall be checked for compressive strength by testing a special straight test sample in accordance with 8.6.1.

The special straight test sample shall be made using the same material mix and manufacturing method as the bend or fitting.

8.7 Corrosion resistance

When flue blocks designated condensate resistance class W (suitable for use in wet operating conditions) are tested as described in Clause A.8, flue blocks shall be designated corrosion class 1 or class 2 depending on the test solution used, provided that the mass loss of the test pieces is not greater than 0,1 % of the initial mass.

Flue blocks designated condensate resistance class D (dry) and which meet the requirements of 8.1, 8.3, 8.5, and 8.6, may be assigned corrosion resistance class 3.

8.8 Condensate resistance

When flue blocks designated W (for use in wet operating conditions) are tested as described in Clause A.8, the maximum amount of test solution passing through the wall of the flue block during any 24_0^{+2} h test period shall not be greater than $0,5 \text{ gh}^{-1}\text{m}^{-2}$ of the flue block external surface.

8.9 Bulk density

When flue blocks are tested as described in Clause A.10, the lowest and highest bulk density value shall be within a limit deviation of $\pm 10 \%$ of the manufacturer's declared bulk density for the block.

8.10 Flexural strength under wind loading

The maximum free standing height of flue blocks shall be no greater than 4,5 times the least lateral overall dimension of the flue block from the last point of lateral support (see Figure 3).

Alternatively, the free standing part of the chimney above the last lateral support of the concrete flue block shall withstand a wind load of $1,5 \text{ kN/m}^2$ (or a value in accordance with national regulations), when tested in accordance with A.9.

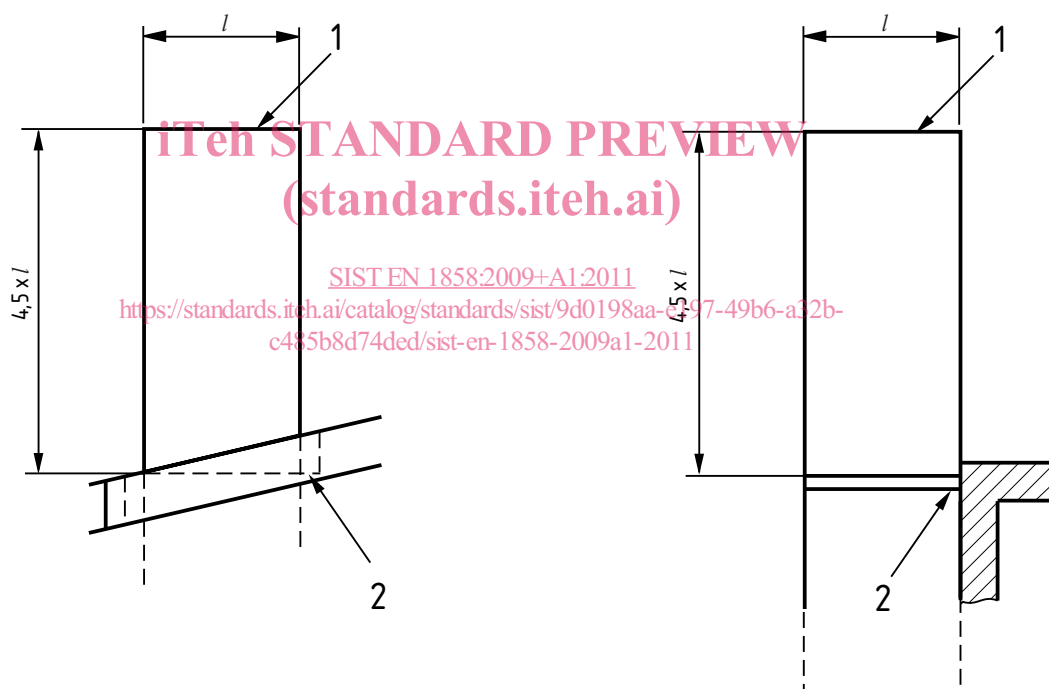

Key

- 1 top of chimney excluding any terminal or chimney pot
- 2 last point of support
- l least lateral overall external dimension of the flue block

Figure 3 — Explanation of last point of support

8.11 Flow resistance

8.11.1 Flow resistance of straight flue blocks

The mean value of roughness for a straight flue block shall be determined either: