

---

---

**Clothing for protection against heat and  
flame — Determination of contact heat  
transmission through protective clothing  
or constituent materials —**

Part 2:

**Test method using contact heat produced  
by dropping small cylinders**

(standards.iteh.ai)

*Vêtements de protection contre la chaleur et la flamme —*

*Détermination de la transmission thermique par contact à travers les  
vêtements de protection ou leurs matériaux constitutifs —*

*Partie 2: Méthode d'essai utilisant la transmission thermique par contact  
produite par des petits cylindres compte-gouttes*

<https://standards.iteh.ai/catalog/standards/sist/0cca6076-e12d-42d3-b663-f9119c920101>



**PDF disclaimer**

This PDF file may contain embedded typefaces. In accordance with Adobe's licensing policy, this file may be printed or viewed but shall not be edited unless the typefaces which are embedded are licensed to and installed on the computer performing the editing. In downloading this file, parties accept therein the responsibility of not infringing Adobe's licensing policy. The ISO Central Secretariat accepts no liability in this area.

Adobe is a trademark of Adobe Systems Incorporated.

Details of the software products used to create this PDF file can be found in the General Info relative to the file; the PDF-creation parameters were optimized for printing. Every care has been taken to ensure that the file is suitable for use by ISO member bodies. In the unlikely event that a problem relating to it is found, please inform the Central Secretariat at the address given below.

**iTeh STANDARD PREVIEW**  
**(standards.iteh.ai)**

[ISO 12127-2:2007](https://standards.iteh.ai/catalog/standards/sist/0cca6076-ef2d-42d3-b663-f5d89a9d0057/iso-12127-2-2007)

<https://standards.iteh.ai/catalog/standards/sist/0cca6076-ef2d-42d3-b663-f5d89a9d0057/iso-12127-2-2007>



**COPYRIGHT PROTECTED DOCUMENT**

© ISO 2007

All rights reserved. Unless otherwise specified, no part of this publication may be reproduced or utilized in any form or by any means, electronic or mechanical, including photocopying and microfilm, without permission in writing from either ISO at the address below or ISO's member body in the country of the requester.

ISO copyright office  
Case postale 56 • CH-1211 Geneva 20  
Tel. + 41 22 749 01 11  
Fax + 41 22 749 09 47  
E-mail [copyright@iso.org](mailto:copyright@iso.org)  
Web [www.iso.org](http://www.iso.org)

Published in Switzerland

## Foreword

ISO (the International Organization for Standardization) is a worldwide federation of national standards bodies (ISO member bodies). The work of preparing International Standards is normally carried out through ISO technical committees. Each member body interested in a subject for which a technical committee has been established has the right to be represented on that committee. International organizations, governmental and non-governmental, in liaison with ISO, also take part in the work. ISO collaborates closely with the International Electrotechnical Commission (IEC) on all matters of electrotechnical standardization.

International Standards are drafted in accordance with the rules given in the ISO/IEC Directives, Part 2.

The main task of technical committees is to prepare International Standards. Draft International Standards adopted by the technical committees are circulated to the member bodies for voting. Publication as an International Standard requires approval by at least 75 % of the member bodies casting a vote.

Attention is drawn to the possibility that some of the elements of this document may be the subject of patent rights. ISO shall not be held responsible for identifying any or all such patent rights.

ISO 12127-2 was prepared by Technical Committee ISO/TC 94, *Personal safety — Protective clothing and equipment*, Subcommittee SC 13, *Protective clothing*.

ISO 12127 consists of the following parts, under the general title *Clothing for protection against heat and flame — Determination of contact heat transmission through protective clothing or constituent materials*:

- *Part 1: Test method using contact heat produced by heating cylinder*
- *Part 2: Test method using contact heat produced by dropping small cylinders*

## Introduction

Protective clothing designed to protect the welders is exposed to high-temperature particles generated from the welding point into the welding environment. These hot particles are small splashes of molten metal, sparks and slag. When the small splashes of molten metal are scattered, they produce heat into the atmosphere, become oxidized and start to change from a molten state into a solidified state.

The diversity of the conditions in which splashes of molten metal and other hot particles may come into contact with materials used for welder's protective clothing makes it difficult to evaluate the hazards that may arise under conditions of use.

The most important protective function is resistance to heat transfer through the layers of clothing from high-temperature metal drops, sparks and solidified hot particles trapped on the fabric in folds or in seamed areas.

The test method described in this part of ISO 12127 allows this heat transfer to be assessed when a hot steel cylinder simulating a small hot particle is allowed to fall on the material. Furthermore, this method can be used to assess charring and hole formation in the material.

This part of ISO 12127 forms a part of a series of standards concerned with clothing designed to protect against heat and fire. This part of ISO 12127 is especially used to assess the consequences for protection of the impact of small hot metal particles on clothing materials.

ISO 12127-1 is a revision of ISO 12127:1996.

ISO 12127-2:2007  
<https://standards.iteh.ai/catalog/standards/sist/0cca6076-cf2d-42d3-b663-f5d89a9d0057/iso-12127-2-2007>

# Clothing for protection against heat and flame — Determination of contact heat transmission through protective clothing or constituent materials —

## Part 2: Test method using contact heat produced by dropping small cylinders

### 1 Scope

This part of ISO 12127 specifies a test method designed to evaluate the heat transfer and the behaviour of materials used for protective clothing when such materials are struck by high temperature metal particles, especially when these are trapped in the folds of the garment in working situations.

The results obtained by this method permit the comparison of the behaviour of different materials which have undergone this test under standardized conditions. They do not permit conclusions to be drawn with respect to contacts with large splashes of molten cast iron or other metal, nor do they allow the behaviour of complete garments under industrial conditions to be predicted.

<https://standards.iteh.ai/catalog/standards/sist/0cca6076-cf2d-42d3-b663-f5d89a9d0057/iso-12127-2-2007>

### 2 Terms and definitions

For the purposes of this document, the following terms and definitions apply.

#### 2.1

##### maximum temperature

$T_{\max}$

maximum temperature of the calorimeter after contact of the cylinder with the sample

#### 2.2

##### starting temperature

$T_0$

temperature of the calorimeter at the starting point of the temperature measurement

#### 2.3

##### start of the temperature measurement

start the temperature measurement at the exact time when the solenoid is switched on

#### 2.4

##### temperature difference

$\Delta T$

change in temperature between the maximum temperature reached and the temperature of the calorimeter at the start of temperature measurement ( $\Delta T = T_{\max} - T_0$ )

#### 2.5

##### cone temperature

$T_c$

temperature of the cone when removed from the oven

2.6

hole

scorched break in the test specimen caused by charring or melting of the material

NOTE The break is assessed as a hole if threads or construction of the material have been clearly diminished or deteriorated, when viewed with the aid of a magnifying glass, in which case a comparison is made of the new and test samples.

3 Principle

This test method consists of two phases, which are carried out in order.

In the first phase of this method, a hot steel cylinder is allowed to fall on a point on a horizontally oriented test specimen, which is then checked for the formation of a hole. The hole formation is assessed immediately after the sample is gently unfastened from the counterweights, if used. No mechanical stress shall be deliberately applied to the sample before examination.

In the second phase, the maximum temperature difference is measured for the materials that passed the first phase. Changes in appearance of the specimen are recorded. Figure 1 shows the overview of the dropping device.

For details and measurements, ask for technical engineering pictures<sup>1)</sup>.

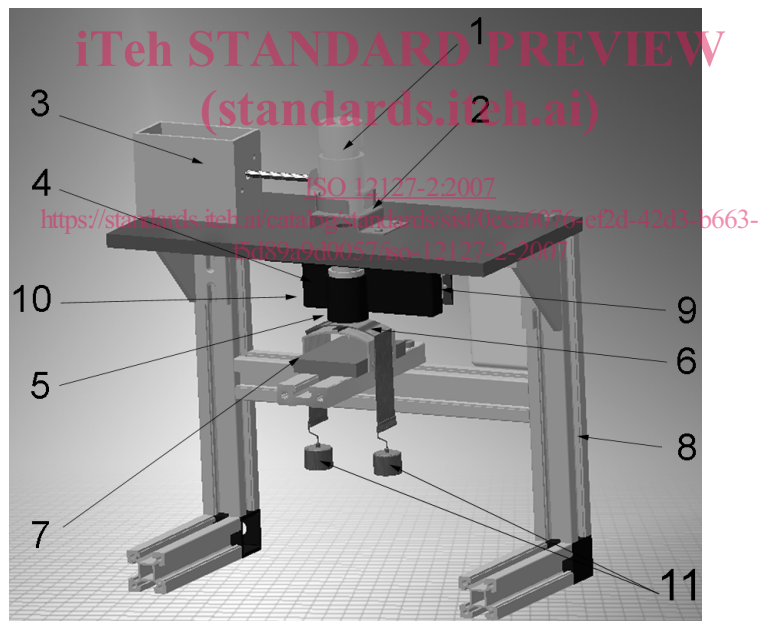

Key

- |                     |   |
|---------------------|---|
| 1 steel cone        | 7 support block for specimen                |
| 2 cone holder       | 8 framework                                 |
| 3 solenoid with rod | 9 aluminium block (connect to cooling unit) |
| 4 insulation brick  | 10 cooling unit                             |
| 5 drop guide        | 11 counterweight                            |
| 6 test specimen     |   |

Figure 1 — Overview of the dropping device

1) Technical engineering pictures are available from Finnish Institute of Occupational Health, Protection and Product Safety, Topeliuksenkatu 41 A, FIN-00320 Helsinki, Finland, Fax +358-30 474 2115.

## 4 Apparatus and materials

**4.1 Heating oven**, capable of reaching a temperature of at least 800 °C and with inside measurements adequate for heating the steel cone, e.g. (110 × 140 × 160) mm.

**4.2 Steel cylinder**, comprising a normal commercial cylindrical roller for roller bearings, with the following dimensions<sup>2)</sup>:

Material: Steel 58-65 HRC

Diameter: Ø 6,0 mm ± 11 µm

Height: 12 mm ± 11 µm

Mass: 2,6 g ± 20 mg

A new steel cylinder is used for every single drop. The flat circular end of the cylinder shall be in contact with the specimen.

**4.3 Steel cone** (Figure 2), in which the steel cylinders are heated and from which they are transferred to the test specimen. The cone is machined from heat resistant steel. A thin slot is machined through the cone for a sliding plate, which releases the cylinder to the specimen.

**4.4 Cone holder** (Figure 3), made from heat resistant steel and which locates the cone in position for releasing the steel cylinder.

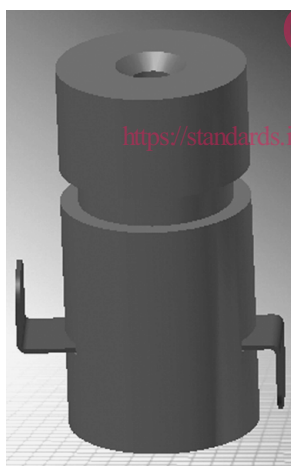

Figure 2 — Steel cone

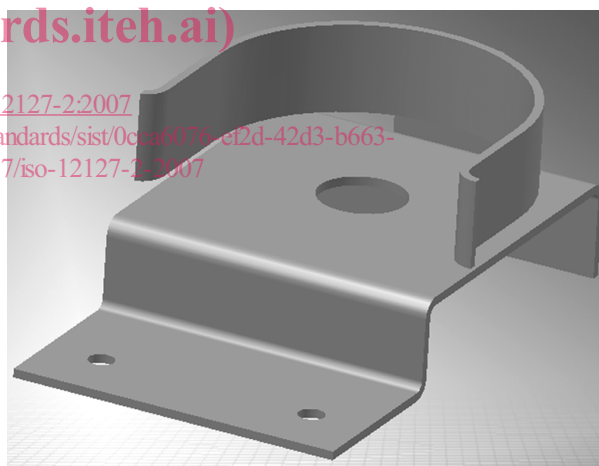

Figure 3 — Cone holder

**4.5 Support table** (Figure 1), which supports the cone on the metal holder, solenoid and cooling unit. The support table is made of heat resistant and thermo negative material.

**4.6 Solenoid with a rod**, used to push the sliding plate inside the cone to release the cylinder (Figure 1). The solenoid is located to one side of the support table so that the rod is able to push the sliding plate and release the cylinder from the cone.

2) Torrington product ZRO. 6 × 12\* PO/M6\* is an example of a suitable product available commercially ([www.torrington.com](http://www.torrington.com)). This information is given for the convenience of users of this document and does not constitute an endorsement by ISO of this product.

**4.7 Drop guide** (Figure 4), designed to guide the steel cylinder to the horizontally oriented test specimen. Drop guide part 1 (ceramic pipe covered with aluminium pipe) is fixed to the support table. Drop guide part 2 is separate and machined from the aluminium pipe. It is surrounded by glued neoprene cover and has inside ceramic pipe with a tapered throat. Part 2 is lowered on the sample.



Figure 4 — Parts of drop guide and assembly

**4.8 Support block for the specimen and calorimeter** (Figure 5), made of a curved aluminium sheet and fitted on a plastic base element. Two blocks are needed:

- one without calorimeter: plain curved aluminium sheet;
- one with the temperature calorimeter: glass-fibre strips are glued on both sides of the calorimeter on the top of the curved aluminium sheet, as shown in Figure 5.

The blocks can be moved forward and backward under the drop guide (see Figure 1).

**4.9 Calorimeter for measuring the temperature under the test specimen**, comprising a K-type thermocouple (Figure 6) inserted into the copper disc. The dimensions of the copper disc are:

- purity 99,9 %;
- thickness  $1,7 \text{ mm} \pm 0,02 \text{ mm}$ ;
- diameter  $8 \text{ mm} \pm 0,02 \text{ mm}$ ;
- mass  $766 \text{ mg} \pm 13 \text{ mg}$ .



The calorimeter manufactured in accordance with Figure 6 is mounted to a ceramic ferrule. This assembly is mounted tightly with a thin layer of heat resistant glue<sup>3)</sup> to the hole in the curved aluminium sheet of the support block. (Figure 5).

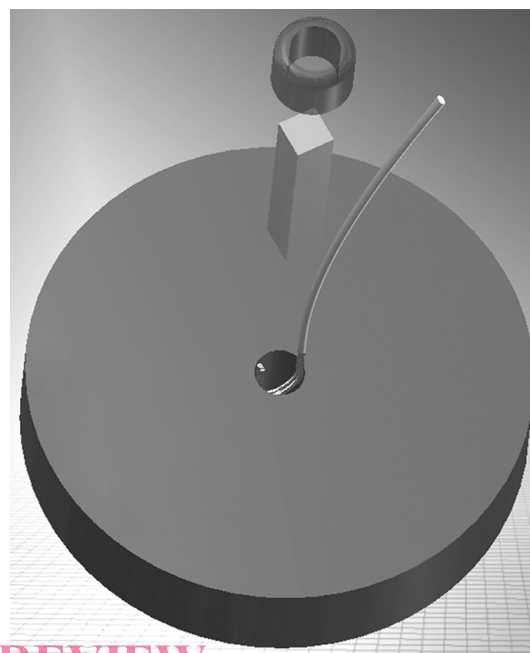
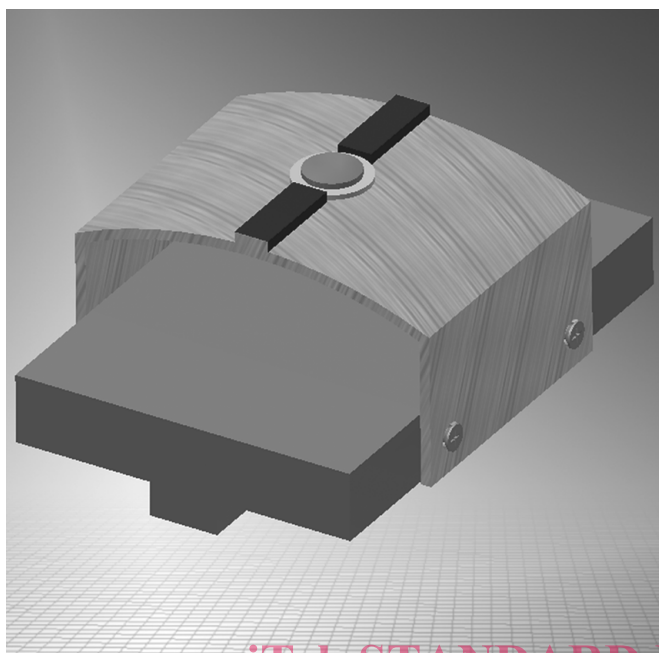

Figure 5 — Support block for the specimen and calorimeter

Figure 6 — Calorimeter, mounting the thermocouple to the copper disc

ISO 12127-2:2007

<https://standards.iteh.ai/catalog/standards/sist/0cca6076-ef2d-42d3-b663-bd89ad007180/iso-12127-2:2007>

**4.10 Thermo electric cooler** (Figure 7), attached to the support table to keep the temperature of the dropping device at constant level. The cooling unit is adjusted to cool the dropping device and calorimeter to  $(20 \pm 1) ^\circ\text{C}$  while the cylinder is heated in the oven. Figure 8 shows a block diagram of the thermo electric cooler.

3) Hottinger Baldwin Messtechnik GmbH, type X60 two component adhesive is an example of a suitable product available commercially

(<http://www.hbm.de/products/SEURLF/ASP/SFS/SUBCAT.15/CATEGORY.3/PROID.371/MM.3,33,140/SFE/ProductDataSheet.htm>). This information is given for the convenience of users of this document and does not constitute an endorsement by ISO of this product.