

SLOVENSKI STANDARD
SIST EN ISO 13628-4:2011/AC:2011
01-september-2011

Industrija za predelavo nafte in zemeljskega plina - Načrtovanje in delovanje podvodnih proizvodnih sistemov - 4. del: Podvodna oprema za glavo izvrtine in križ na ustjih vrtin - Tehnični popravek (ISO 13628-4:2010/Cor 1:2011)

Petroleum and natural gas industries - Design and operation of subsea production systems - Part 4: Subsea wellhead and tree equipment - Technical Corrigendum 1 (ISO 13628-4:2010/Cor 1:2011)

Erdöl- und Erdgasindustrie - Auslegung und Betrieb von Unterwasser-Produktionssystemen - Teil 4: Bohrloch- und E-Kreuz-Ausrüstungen für den Unterwassereinsatz (ISO 13628-4:2010/Cor 1:2011)

[SIST EN ISO 13628-4:2011/AC:2011](https://standards.iteh.ai/catalog/standards/sist/c1b773c8-6799-4960-970b-222222222222/iso-13628-4:2010-cor-1:2011)

[https://standards.iteh.ai/catalog/standards/sist/c1b773c8-6799-4960-970b-](https://standards.iteh.ai/catalog/standards/sist/c1b773c8-6799-4960-970b-222222222222/iso-13628-4:2010-cor-1:2011)

Industries du pétrole et du gaz naturel - Conception et exploitation des systèmes de production immergés - Partie 4: Équipements immergés de tête de puits et tête de production - Rectificatif technique 1 (ISO 13628-4:2010/Cor 1:2011)

Ta slovenski standard je istoveten z: EN ISO 13628-4:2010/AC:2011

ICS:

75.180.10	Oprema za raziskovanje in odkopavanje	Exploratory and extraction equipment
-----------	---------------------------------------	--------------------------------------

SIST EN ISO 13628-4:2011/AC:2011 **en,fr**

iTeh STANDARD PREVIEW
(standards.iteh.ai)

SIST EN ISO 13628-4:2011/AC:2011

<https://standards.iteh.ai/catalog/standards/sist/c1b773c8-6799-4960-970b-3ddaebff05ce/sist-en-iso-13628-4-2011-ac-2011>

EUROPEAN STANDARD

EN ISO 13628-4:2010/AC

NORME EUROPÉENNE

June 2011

EUROPÄISCHE NORM

Juin 2011

Juni 2011

ICS 75.180.10

English version
Version Française
Deutsche Fassung

Petroleum and natural gas industries - Design and operation of subsea production systems - Part 4: Subsea wellhead and tree equipment - Technical Corrigendum 1 (ISO 13628-4:2010/Cor 1:2011)

Industries du pétrole et du gaz naturel - Conception et exploitation des systèmes de production immergés - Partie 4: Équipements immergés de tête de puits et tête de production - Rectificatif technique 1 (ISO 13628-4:2010/Cor 1:2011)

Erdöl- und Erdgasindustrie - Auslegung und Betrieb von Unterwasser-Produktionssystemen - Teil 4: Bohrloch- und E-Kreuz-Ausrüstungen für den Unterwassereinsatz (ISO 13628-4:2010/Cor 1:2011)

iTeh STANDARD PREVIEW

This corrigendum becomes effective on 15 June 2011 for incorporation in the three official language versions of the EN.

Ce corrigendum prendra effet le 15 juin 2011 pour incorporation dans les trois versions linguistiques officielles de la EN.

Die Berichtigung tritt am 15. Juni 2011 zur Einarbeitung in die drei offiziellen Sprachfassungen der EN in Kraft.



EUROPEAN COMMITTEE FOR STANDARDIZATION
COMITÉ EUROPÉEN DE NORMALISATION
EUROPÄISCHES KOMITEE FÜR NORMUNG

Management Centre: Avenue Marnix 17, B-1000 Brussels

© 2011 CEN All rights of exploitation in any form and by any means reserved worldwide for CEN national Members.
Tous droits d'exploitation sous quelque forme et de quelque manière que ce soit réservés dans le monde entier aux membres nationaux du CEN.
Alle Rechte der Verwertung, gleich in welcher Form und in welchem Verfahren, sind weltweit den nationalen Mitgliedern von CEN vorbehalten.

Ref. No.: EN ISO 13628-4:2010/AC:2011 D/E/F

Contents

Page

Foreword.....3

**iTeh STANDARD PREVIEW
(standards.iteh.ai)**

[SIST EN ISO 13628-4:2011/AC:2011](https://standards.iteh.ai/catalog/standards/sist/c1b773c8-6799-4960-970b-3ddaebff05ce/sist-en-iso-13628-4-2011-ac-2011)
<https://standards.iteh.ai/catalog/standards/sist/c1b773c8-6799-4960-970b-3ddaebff05ce/sist-en-iso-13628-4-2011-ac-2011>

Foreword

This document (EN ISO 13628-4:2010/AC:2011) has been prepared by Technical Committee ISO/TC 67 "Materials, equipment and offshore structures for petroleum, petrochemical and natural gas industries" in collaboration with Technical Committee CEN/TC 12 "Materials, equipment and offshore structures for petroleum, petrochemical and natural gas industries" the secretariat of which is held by AFNOR.

Endorsement notice

The text of ISO 13628-4:2010/Cor 1:2011 has been approved by CEN as a EN ISO 13628-4:2010/AC:2011 without any modification.

iTeh STANDARD PREVIEW (standards.iteh.ai)

[SIST EN ISO 13628-4:2011/AC:2011](https://standards.iteh.ai/catalog/standards/sist/c1b773c8-6799-4960-970b-3ddaebff05ce/sist-en-iso-13628-4-2011-ac-2011)

<https://standards.iteh.ai/catalog/standards/sist/c1b773c8-6799-4960-970b-3ddaebff05ce/sist-en-iso-13628-4-2011-ac-2011>

iTeh STANDARD PREVIEW
(standards.iteh.ai)

[SIST EN ISO 13628-4:2011/AC:2011](https://standards.iteh.ai/catalog/standards/sist/c1b773c8-6799-4960-970b-3ddaebff05ce/sist-en-iso-13628-4-2011-ac-2011)

<https://standards.iteh.ai/catalog/standards/sist/c1b773c8-6799-4960-970b-3ddaebff05ce/sist-en-iso-13628-4-2011-ac-2011>



INTERNATIONAL STANDARD ISO 13628-4:2010
TECHNICAL CORRIGENDUM 1

Published 2011-06-15

INTERNATIONAL ORGANIZATION FOR STANDARDIZATION • МЕЖДУНАРОДНАЯ ОРГАНИЗАЦИЯ ПО СТАНДАРТИЗАЦИИ • ORGANISATION INTERNATIONALE DE NORMALISATION

**Petroleum and natural gas industries — Design and operation
of subsea production systems —**

**Part 4:
Subsea wellhead and tree equipment**

TECHNICAL CORRIGENDUM 1

*Industries du pétrole et du gaz naturel — Conception et exploitation des systèmes de production immergés —
Partie 4: Équipements immergés de tête de puits et tête de production*

RECTIFICATIF TECHNIQUE 1

(standards.iteh.ai)

[SIST EN ISO 13628-4:2011/AC:2011](https://standards.iteh.ai/catalog/standards/sist/c1b773c8-6799-4960-970b-3ddaebff05ce/sist-en-iso-13628-4-2011-ac-2011)

<https://standards.iteh.ai/catalog/standards/sist/c1b773c8-6799-4960-970b-3ddaebff05ce/sist-en-iso-13628-4-2011-ac-2011>

Technical Corrigendum 1 to ISO 13628-4:2010 was prepared by Technical Committee ISO/TC 67, *Materials, equipment and offshore structures for petroleum, petrochemical and natural gas industries*, Subcommittee SC 4, *Drilling and production equipment*.

Page 60, Table 11

Replace the existing table and figure with the following.

Table 11 — Hub and bore dimensions for type 17SV flanges for 34,5 MPa (5 000 psi) rated working pressure

Dimensions in millimetres (inches) unless otherwise indicated

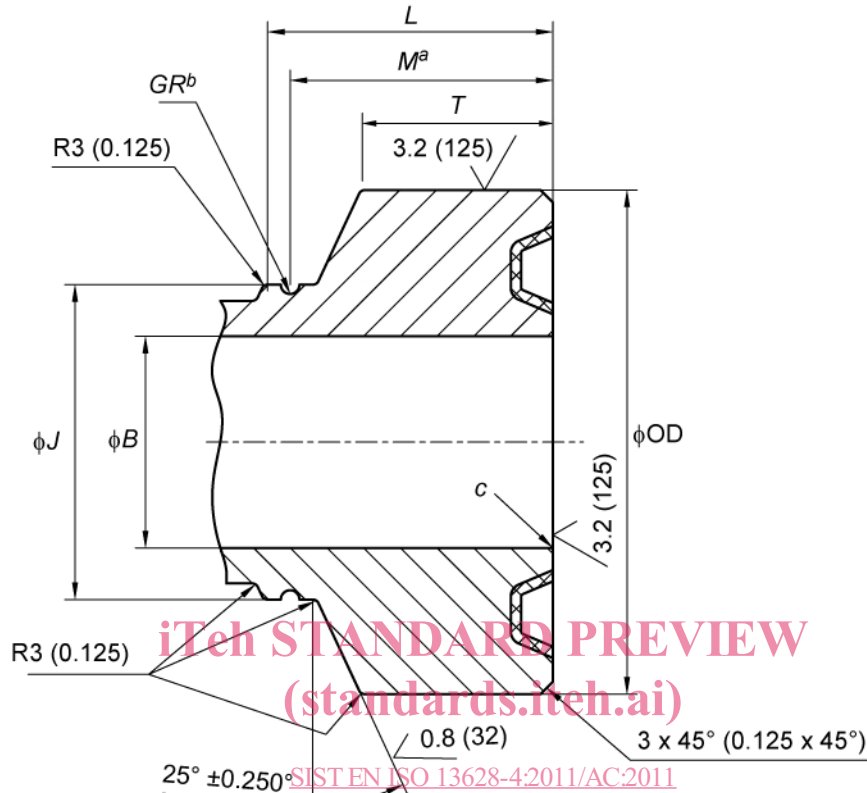

- a Groove location, $M \begin{matrix} +0,7 \\ 0 \end{matrix} \begin{pmatrix} +0,030 \\ 0 \end{pmatrix}$.
- b Groove radius, $GR \begin{matrix} +0,1 \\ 0 \end{matrix} \begin{pmatrix} +0,005 \\ 0 \end{pmatrix}$.
- c Break sharp corners.

Hub ^a and bore dimensions														
Nominal size and bore		Outside diameter		Total thickness		Large diameter of neck		Length of neck		Groove location		Retainer groove radius		Ring gasket no.
		OD		T		J		L		M		GR		BX
mm	(in)	mm	(in)	mm	(in)	mm	(in)	mm	(in)	mm	(in)	mm	(in)	
52	(2 1/16)	128	(5,031)	29,5	(1,166)	93	(3,656)	84	(3,282)	74	(2,907)	3	(0,125)	152
65	(2 9/16)	147	(5,781)	29,5	(1,166)	112	(4,406)	84	(3,282)	74	(2,907)	3	(0,125)	153
78	(3 1/8)	160	(6,312)	29,5	(1,166)	126	(4,938)	88	(3,432)	78	(3,067)	3	(0,125)	154
103	(4 1/16)	194	(7,625)	30,5	(1,197)	159	(6,250)	96	(3,757)	86	(3,382)	3	(0,125)	155
130	(5 1/8)	240	(9,380)	36,0	(1,410)	197	(7,755)	121	(4,732)	111	(4,357)	3	(0,125)	169
179	(7 1/16)	272	(10,700)	41,5	(1,622)	231	(9,075)	141	(5,541)	127	(4,979)	5	(0,188)	156
228	(9)	340	(13,250)	41,5	(1,622)	296	(11,625)	156	(6,113)	141	(5,551)	5	(0,188)	157
279	(11)	415	(16,250)	42,0	(1,654)	372	(14,625)	162	(6,932)	162	(6,370)	5	(0,188)	158
346	(13 5/8)	524	(20,625)	47,52	(1,871)	489	(19,000)	182	(7,150)	168	(6,614)	5	(0,188)	160

^a Hub material strength shall be equal to or greater than 517,1 MPa (75 000 psi).

Page 170, Figure A.3

Replace the existing figure with the following.

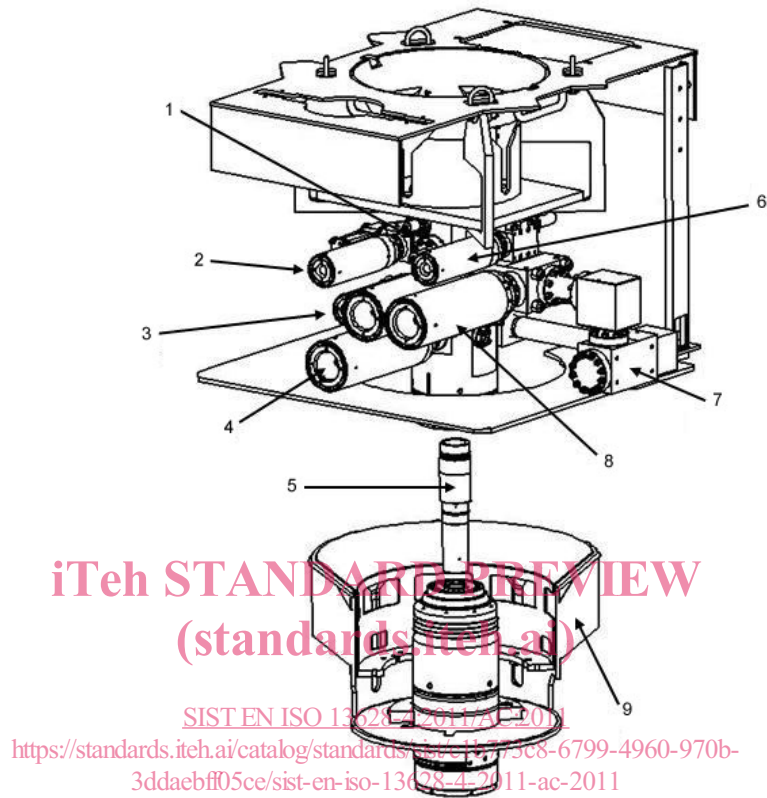

Key

1	swab valves	5	tubing hanger	9	GRA, CGB, or tubing head
2	annulus wing valve	6	crossover valve		
3	annulus master valve	7	production outlet		
4	master valve	8	wing valve		

Figure A.3 — Guidelineless style vertical tree