**Petroleum and related products —
Determination of the ageing behaviour of
inhibited oils and fluids — TOST test —**

**Part 4:
Procedure for industrial gear oils**

iTeh STANDARD PREVIEW

(standards.iteh.ai)

*Pétrole et produits connexes — Détermination du comportement au
vieillessement des fluides et huiles inhibés — Essai TOST —*

Partie 4: Méthode pour les huiles pour engrenages industriels

[ISO 4263-4:2006](#)

<https://standards.iteh.ai/catalog/standards/sist/c0648e6d-e46c-42cc-80a1-70775a4dfff3/iso-4263-4-2006>



PDF disclaimer

This PDF file may contain embedded typefaces. In accordance with Adobe's licensing policy, this file may be printed or viewed but shall not be edited unless the typefaces which are embedded are licensed to and installed on the computer performing the editing. In downloading this file, parties accept therein the responsibility of not infringing Adobe's licensing policy. The ISO Central Secretariat accepts no liability in this area.

Adobe is a trademark of Adobe Systems Incorporated.

Details of the software products used to create this PDF file can be found in the General Info relative to the file; the PDF-creation parameters were optimized for printing. Every care has been taken to ensure that the file is suitable for use by ISO member bodies. In the unlikely event that a problem relating to it is found, please inform the Central Secretariat at the address given below.

iTeh STANDARD PREVIEW
(standards.iteh.ai)

[ISO 4263-4:2006](#)

<https://standards.iteh.ai/catalog/standards/sist/c0648e6d-e46c-42cc-80a1-70775a4dfff3/iso-4263-4-2006>

© ISO 2006

All rights reserved. Unless otherwise specified, no part of this publication may be reproduced or utilized in any form or by any means, electronic or mechanical, including photocopying and microfilm, without permission in writing from either ISO at the address below or ISO's member body in the country of the requester.

ISO copyright office
Case postale 56 • CH-1211 Geneva 20
Tel. + 41 22 749 01 11
Fax + 41 22 749 09 47
E-mail copyright@iso.org
Web www.iso.org

Published in Switzerland

Contents

Page

Foreword.....	iv
1 Scope	1
2 Normative references	1
3 Terms and definitions.....	2
4 Principle.....	2
5 Reagents and materials	2
6 Apparatus	3
7 Sampling.....	3
8 Preparation of apparatus — Cleaning of glassware	5
9 Procedure	5
10 Expression of results	6
11 Precision.....	6
12 Test report	7
Annex A (normative) Liquid-in-glass thermometer specifications	8
Annex B (normative) Method for the determination of the insoluble content (precipitation number).....	9
Annex C (informative) Method for the determination of the sediment content by filtration.....	11
Annex D (informative) Method for the determination of the variation of the additives content.....	12
Annex E (informative) Method for the determination of the infra-red oxidation.....	13
Bibliography	15

Foreword

ISO (the International Organization for Standardization) is a worldwide federation of national standards bodies (ISO member bodies). The work of preparing International Standards is normally carried out through ISO technical committees. Each member body interested in a subject for which a technical committee has been established has the right to be represented on that committee. International organizations, governmental and non-governmental, in liaison with ISO, also take part in the work. ISO collaborates closely with the International Electrotechnical Commission (IEC) on all matters of electrotechnical standardization.

International Standards are drafted in accordance with the rules given in the ISO/IEC Directives, Part 2.

The main task of technical committees is to prepare International Standards. Draft International Standards adopted by the technical committees are circulated to the member bodies for voting. Publication as an International Standard requires approval by at least 75 % of the member bodies casting a vote.

Attention is drawn to the possibility that some of the elements of this document may be the subject of patent rights. ISO shall not be held responsible for identifying any or all such patent rights.

ISO 4263-4 was prepared by Technical Committee ISO/TC 28, *Petroleum products and lubricants*.

ISO 4263 consists of the following parts under the general title *Petroleum and related products — Determination of the ageing behaviour of inhibited oils and fluids — TOST test*:

— Part 1: Procedure for mineral oils

— Part 2: Procedure for category HFC hydraulic fluids

— Part 3: Anhydrous procedure for synthetic hydraulic fluids

— Part 4: Procedure for industrial gear oils

Petroleum and related products — Determination of the ageing behaviour of inhibited oils and fluids — TOST test —

Part 4: Procedure for industrial gear oils

WARNING — The use of this part of ISO 4263 may involve hazardous materials, operations and equipment. This part of ISO 4263 does not purport to address all of the safety problems associated with its use. It is the responsibility of the user of this part of ISO 4263 to establish appropriate safety and health practices and determine the applicability of regulatory limitations prior to use.

1 Scope

This part of ISO 4263 specifies a method for the determination of the ageing behaviour of gear oils of categories CKC, CKD, CKS and CKT as defined in ISO 6743-6^[5]. The ageing is accelerated by the presence of air and elevated temperatures, and the degradation of the oil is assessed by the change in kinematic viscosity at 100 °C, the insoluble content (precipitation number), and possibly the acid number increase, the sediment content by filtration, the additives content variation and the infra-red oxidation.

2 Normative references

ISO 4263-4:2006

[https://standards.iteh.ai/catalog/standards/sist/c0648e6d-e46c-42cc-80a1-](https://standards.iteh.ai/catalog/standards/sist/c0648e6d-e46c-42cc-80a1-70775a4d483/iso-4263-4-2006)

The following referenced documents are indispensable for the application of this document. For dated references, only the edition cited applies. For undated references, the latest edition of the referenced document (including any amendments) applies.

ISO 2977:1997, *Petroleum products and hydrocarbon solvents — Determination of aniline point and mixed aniline point*

ISO 3104:1994, *Petroleum products — Transparent and opaque liquids — Determination of kinematic viscosity and calculation of dynamic viscosity*

ISO 3170:2004, *Petroleum liquids — Manual sampling*

ISO 3405:2000, *Petroleum products — Determination of distillation characteristics at atmospheric pressure*

ISO 3696:1987, *Water for analytical laboratory use — Specification and test methods*

ISO 3734:1997, *Petroleum products — Determination of water and sediment in residual fuel oils — Centrifuge method*

ISO 12185:1996, *Crude petroleum and petroleum products — Determination of density — Oscillating U-tube method*

3 Terms and definitions

For the purposes of this document, the following terms and definitions apply.

3.1 insoluble content
precipitation number
number of millilitres of precipitate formed when 10 ml of lubricating oil are mixed with 90 ml of precipitation naphtha, and centrifuged under the conditions of the test

3.2 sediment by filtration
amount of insoluble matter, expressed in milligrams per 100 ml, retained on a filtration membrane of 1,2 µm pore size after filtration under vacuum

4 Principle

A test portion is reacted, in the absence of light, in the presence of air, and at a temperature appropriate to the type of industrial gear oil under test: 95 °C for CKC type; 121 °C for CKD type; 150 °C for CKS and CKT types. At the end of a 312 h period, the increase in kinematic viscosity at 100 °C, the insoluble content (precipitation number), the increase in acid number (if required), the sediment content by filtration, the additives depletion and the infra-red oxidation, are determined.

5 Reagents and materials

5.1 Water, unless otherwise specified, in accordance with the requirements of grade 2 as defined in ISO 3696:1987. Potable water means tap water, unless normal piped supplies are contaminated with particulate or highly soluble mineral content.

5.2 Heptane (C₇H₁₆), of reagent grade and of minimum purity 99,75 %.

5.3 Acetone, (CH₃COCH₃), of general purpose reagent grade (GPR).

5.4 Air, dried, oil-free, at constant pressure.

Supply from air cylinders or from a compressed air circuit is possible; this should be utilized via a regulation system to improve the consistency of the air flow.

5.5 Cleaning solutions

5.5.1 Strong oxidizing acid solution

The reference strong oxidizing cleaning solution on which precision was based, is chromosulfuric acid (see the following warning), but alternative non-chromium containing solutions, such as ammonium persulfate in concentrated sulphuric acid (8 g/l) have been found to give satisfactory cleanliness. A 10 % solution of three parts of hydrochloric acid (1 mol/l) and one part of orthophosphoric acid (concentrated GPR grade) removes iron oxide deposits.

WARNING — Chromosulfuric acid is a health hazard. It is toxic, a recognized carcinogen as it contains Cr(VI) compounds, highly corrosive and potentially hazardous in contact with organic materials. When using chromosulfuric acid cleaning solution, eye protection and protective clothing are essential. Never pipette the cleaning solution by mouth. After use, do not pour cleaning solution down the drain, but neutralize it with great care owing to the concentrated sulfuric acid present, and dispose of it in accordance with standard procedures for toxic laboratory waste (chromium is highly dangerous to the environment).

Strongly oxidizing acid cleaning solutions that are chromium-free are also highly corrosive and potentially hazardous in contact with organic materials, but do not contain chromium which has special disposal problems.

5.5.2 Surfactant cleaning fluid

A proprietary strong surfactant cleaning fluid is a preferred alternative to the strong oxidizing cleaning solution whenever the condition of the glassware permits this.

5.5.3 Laboratory detergent

The detergent shall be water soluble.

6 Apparatus

6.1 Oxidation cell, consisting of a large test tube of borosilicate glass, 600 mm in length, of 41 mm inside diameter, with a graduation mark to indicate a volume of 300 ml \pm 1 ml at 20 °C, an air-delivery tube and a slotted cork stopper. The design and dimensions shall be as illustrated in Figure 1.

New corks should be used for each test.

6.2 Heating bath, consisting of a thermostatically controlled bath capable of maintaining the test oil portion in the oxidation cell at the specified temperature \pm 0,2 °C. It shall be large enough to hold the required number of oxidation cells (6.1) immersed in the heat-transfer medium so that the bath liquid is at least 50 mm above the level of the oil sample. It shall be constructed to ensure that light is excluded from the test portions during the test. If a fluid bath is used, it shall be fitted with a suitable stirring system to provide a uniform temperature throughout the bath. If the fluid bath is fitted with a top, the total length of the oxidation cell within the bath shall be 390 mm \pm 10 mm.

6.3 Flowmeters, capable of measuring a flow of air of 10 l/h with an accuracy of \pm 0,5 l/h, one per oxidation cell is required.

6.4 Temperature-measurement devices

6.4.1 Heating bath. The temperature in liquid heating baths shall be measured by either a liquid-in-glass thermometer meeting the requirements of the specification given in Annex A, or an equivalent temperature-measurement system readable to \pm 0,2 °C and calibrated to better than \pm 0,2 °C.

6.4.2 Oxidation cell. The temperature in the oxidation cell shall be measured by either a liquid-in-glass thermometer meeting the requirements of the specification given in Annex A, or an equivalent temperature-measurement system readable to \pm 0,2 °C and calibrated to better than \pm 0,2 °C.

6.5 Air-supply tube. Flexible polyvinylchloride (PVC) tubing of approximately 6,4 mm inside diameter and 1,5 mm wall thickness, is required to deliver air to the oxidation cell.

6.6 Air dryer. Between the air supply and the flowmeters, the air shall pass through a drying tower packed with indicating grade anhydrous calcium sulfate or equivalent. The quantity of desiccant shall be sufficient to last for the entire test.

7 Sampling

Unless otherwise specified, samples shall be obtained in accordance with the procedures described in ISO 3170.

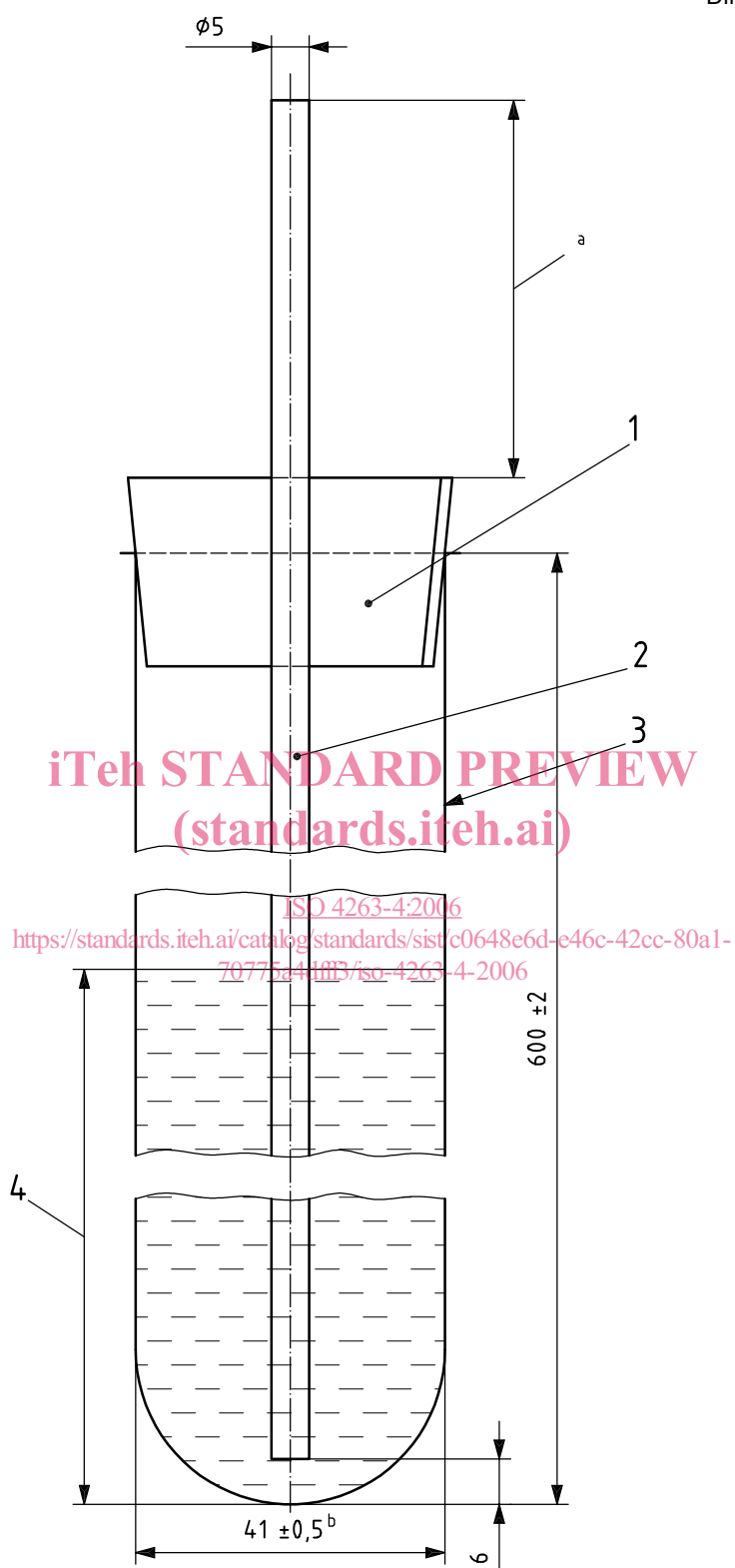

Key

- 1 slotted cork stopper
- 2 glass air-supply tube
- 3 borosilicate test tube
- 4 test sample, 300 ml

- a 60 to 80 mm.
- b Internal diameter.

Figure 1 — Oxidation cell

8 Preparation of apparatus — Cleaning of glassware

8.1 Cleaning new glassware

Wash new air-delivery tubes and oxidation cells with hot detergent solution (see 5.5.3) and rinse thoroughly with potable water (5.1). Clean the interior of the oxidation cells, and both interiors and exteriors of the air-delivery tubes by either soaking for 24 h in a 10 % solution of the surfactant cleaning fluid (5.5.2), or by washing in strong oxidizing acid solution (5.5.1). Rinse all parts thoroughly with potable water followed by water (5.1) and allow to air dry, either in an oven or by a final rinse of acetone (5.3) followed by air drying at ambient temperature.

8.2 Cleaning used glassware

Immediately following the termination of a test, after inspection of the tube, rinse all glassware with heptane (5.2) to remove all traces of oil. Wash with hot detergent solution (see 5.5.3) using a long-handled brush and rinse thoroughly with potable water. After all deposits have been removed, follow the cleaning procedure described in 8.1. Store all cleaned glassware in a dry, dust-free condition until required.

9 Procedure

9.1 On the fresh oil, determine the viscosity at 100 °C in accordance with ISO 3104, and the insoluble content (precipitation number) (see Annex B).

It is recommended that the additive content (see Annex D), and the acid number according to either ISO 6618^[3] or ISO 6619^[4], are determined; an infra-red (IR) spectrum can be recorded in the range 2 000 cm⁻¹ to 1 650 cm⁻¹, using a cell with a calibrated thickness (see Annex E).

9.2 Adjust the heating bath to a temperature high enough to maintain the test oil in the desired number of oxidation cells at the required temperature $\pm 0,2$ °C. The temperature shall be chosen according to the type of fluid tested: 95 °C for the CKO-type products; 121 °C for the CKD type, and 150 °C for the CKS and CKT types.

9.3 Connect the air-delivery tube to the air supply through the flowmeter (6.3) using flexible tubing (6.5). Adjust the flow of air to 10 l/h $\pm 0,5$ l/h. After 30 min, check the test oil temperature and adjust the heating bath temperature if necessary. Check the air-flow rate, make the necessary adjustments, and record the time at which this is carried out. Check the temperature of the test oil once every hour for at least 3 h, making the necessary adjustments each time, until a constant test oil temperature at $\pm 0,2$ °C is read twice in succession. Maintain the heating bath at a constant temperature, checking it daily throughout the duration of the test. The air-flow rate shall be checked at least twice a day, and adjusted whenever necessary.

9.4 After 312 h ± 2 h, disconnect the air-delivery tube and remove the cells from the heating bath. Mix the oil thoroughly, and remove sufficient sample for the determination of:

- a) the viscosity at 100 °C, in accordance with ISO 3104;
- b) the insoluble content (precipitation number) (see Annex B).

It is recommended that the sediment content by filtration (see Annex C), the additives content of the filtrate (see Annex D), and the acid number according to either ISO 6618^[3] or ISO 6619^[4], are determined on the sample. It is also recommended that the infra-red spectrum in the range from 2 000 cm⁻¹ to 1 650 cm⁻¹ is recorded, measuring the absorbance at 1 710 cm⁻¹, for the determination of the infra-red oxidation (see Annex E).

Rinse the outside of the oxidation cell to remove the heating fluid; then pour the oil from the oxidation cell into a beaker and place the oxidation cell vertically upside down in the beaker for 72 h to allow the oil to completely drain from it. Inspect qualitatively the oxidation cell in order to rate the deposits (see Clause 10) at the oil/air interface level, on the walls and in the bottom of the cell.

NOTE Washing of the tube with a solvent such as heptane (5.2) can facilitate the inspection of the cell.

10 Expression of results

The ageing resistance of the oil shall be expressed by:

- a) the increase in kinematic viscosity at 100 °C;
- b) the increase of the precipitation number;
- c) the appearance of the tube after the test, the presence of deposits and their adhesivity, recorded as appropriate as follows:

- deposits: — nil
— slight
— heavy
— very heavy
- adhesivity: — weak
— strong

NOTE The resistance to ageing can be also assessed by

- the variation of the acid number;
- the sediment content by filtration (see Annex C);
- the variation of the additives content (see Annex D);
- the infra-red oxidation (see Annex E).

11 Precision

11.1 General

The precision has only been established for a temperature of 95 °C, and was not determined in accordance with ISO 4259^[1]. For the other temperatures, the precision is not known.

11.2 Viscosity increase

11.2.1 Repeatability, *r*

The difference between two test results obtained by the same operator with the same apparatus under constant operating conditions on identical test material would in the long run, in the normal and correct operation of the test method, exceed the values shown in Figure 2 a) in only one case in twenty.

11.2.2 Reproducibility, *R*

The difference between two single and independent test results obtained by different operators working in different laboratories on identical test material would in the long run, in the normal and correct operation of the test method, exceed the values shown in Figure 2 a) in only one case in twenty.

11.3 Precipitation number increase

11.3.1 Repeatability, r

The difference between two test results obtained by the same operator with the same apparatus under constant operating conditions on identical test material would in the long run, in the normal and correct operation of the test method, exceed the values shown in Figure 2 b) in only one case in twenty.

11.3.2 Reproducibility, R

The difference between two single and independent test results obtained by different operators working in different laboratories on identical test material would in the long run, in the normal and correct operation of the test method, exceed the values shown in Figure 2 b) in only one case in twenty.

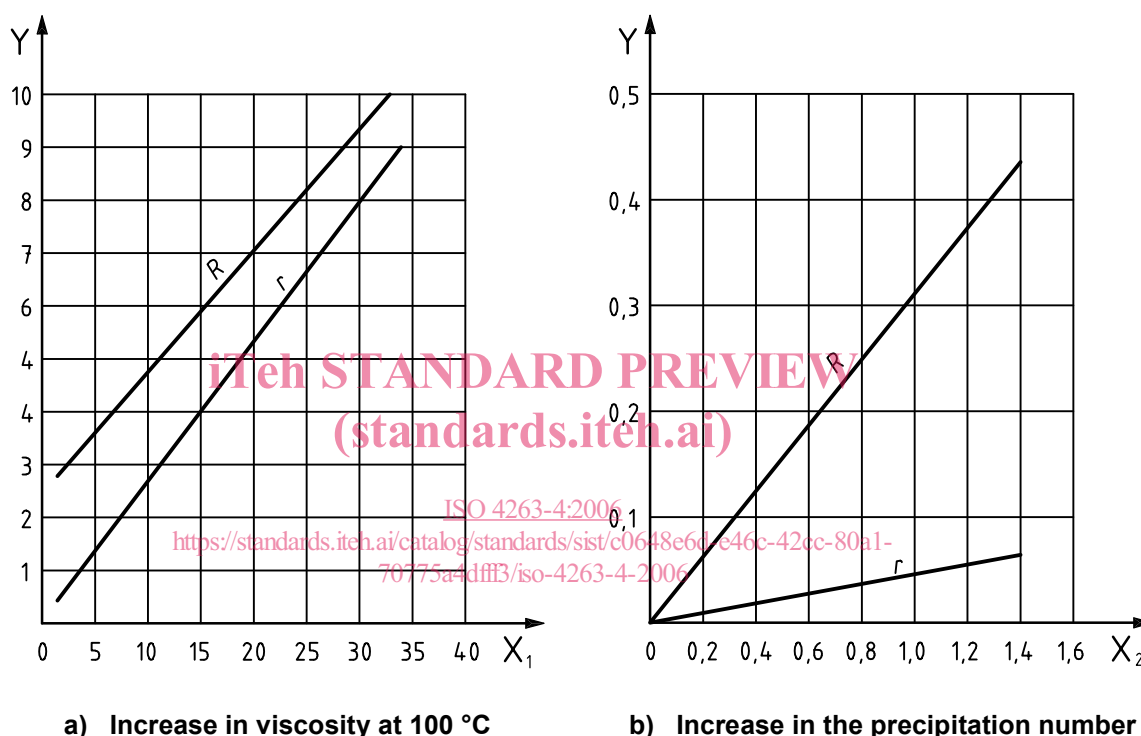

Key

- X₁ viscosity, in percent
- X₂ precipitation number, in millilitres
- Y maximum acceptable difference for paired results
- R reproducibility
- r reproducibility

Figure 2 — Precision data

12 Test report

The test report shall contain at least the following information:

- a) a reference to this part of ISO 4263;
- b) the type and complete identification of the product tested;
- c) the result of the test (see Clause 10);
- d) any deviation, by agreement or otherwise, from the procedure specified;
- e) the date of the test.