



SLOVENSKI STANDARD

SIST EN 14617-4:2012

01-julij-2012

Nadomešča:
SIST EN 14617-4:2005

Aglomeriran kamen - Preskusne metode - 4. del: Ugotavljanje obrabne obstojnosti

Agglomerated stone - Test methods - Part 4: Determination of the abrasion resistance

Künstlich hergestellter Stein - Prüfverfahren - Teil 4: Bestimmung der Abriebbeständigkeit

Pierre agglomérée - Méthodes d'essai - Partie 4: Détermination de la résistance à l'usure

Ta slovenski standard je istoveten z: EN 14617-4:2012

ICS:

91.100.15 Mineralni materiali in izdelki Mineral materials and products

SIST EN 14617-4:2012

en,fr,de

iTeh STANDARD PREVIEW
(standards.iteh.ai)

SIST EN 14617-4:2012

<https://standards.iteh.ai/catalog/standards/sist/99ff1438-7e94-41fa-a247-a76f7a9600e1/sist-en-14617-4-2012>

EUROPEAN STANDARD

EN 14617-4

NORME EUROPÉENNE

EUROPÄISCHE NORM

April 2012

ICS 91.100.15

Supersedes EN 14617-4:2005

English Version

Agglomerated stone - Test methods - Part 4: Determination of the abrasion resistance

Pierre agglomérée - Méthodes d'essai - Partie 4:
Détermination de la résistance à l'usure

Künstlich hergestellter Stein - Prüfverfahren - Teil 4:
Bestimmung der Abriebbeständigkeit

This European Standard was approved by CEN on 9 March 2012.

CEN members are bound to comply with the CEN/CENELEC Internal Regulations which stipulate the conditions for giving this European Standard the status of a national standard without any alteration. Up-to-date lists and bibliographical references concerning such national standards may be obtained on application to the CEN-CENELEC Management Centre or to any CEN member.

This European Standard exists in three official versions (English, French, German). A version in any other language made by translation under the responsibility of a CEN member into its own language and notified to the CEN-CENELEC Management Centre has the same status as the official versions.

CEN members are the national standards bodies of Austria, Belgium, Bulgaria, Croatia, Cyprus, Czech Republic, Denmark, Estonia, Finland, France, Germany, Greece, Hungary, Iceland, Ireland, Italy, Latvia, Lithuania, Luxembourg, Malta, Netherlands, Norway, Poland, Portugal, Romania, Slovakia, Slovenia, Spain, Sweden, Switzerland, Turkey and United Kingdom.

[SIST EN 14617-4:2012](https://standards.iteh.ai/catalog/standards/sist/99ff1438-7e94-41fa-a247-a76f7a9600e1/sist-en-14617-4-2012)

<https://standards.iteh.ai/catalog/standards/sist/99ff1438-7e94-41fa-a247-a76f7a9600e1/sist-en-14617-4-2012>



EUROPEAN COMMITTEE FOR STANDARDIZATION
COMITÉ EUROPÉEN DE NORMALISATION
EUROPÄISCHES KOMITEE FÜR NORMUNG

Management Centre: Avenue Marnix 17, B-1000 Brussels

Contents

Page

Foreword.....	3
1 Scope	4
2 Normative references	4
3 Principle of the test method	4
4 Abrasive material	4
5 Apparatus	4
6 Calibration	7
7 Test specimen preparation	7
7.1 Sampling	7
7.2 Specimens preparation	7
8 Procedure	8
8.1 Test method.....	8
8.2 Groove measurement.....	8
9 Test results	8
10 Test report	9
Bibliography	10

iTeh STANDARD PREVIEW
(standards.iteh.ai)

[SIST EN 14617-4:2012](https://standards.iteh.ai/catalog/standards/sist/99ff1438-7e94-41fa-a247-a76f7a9600e1/sist-en-14617-4-2012)

<https://standards.iteh.ai/catalog/standards/sist/99ff1438-7e94-41fa-a247-a76f7a9600e1/sist-en-14617-4-2012>

Foreword

This document (EN 14617-4:2012) has been prepared by Technical Committee CEN/TC 246 "Natural stones", the secretariat of which is held by UNI.

This European Standard shall be given the status of a national standard, either by publication of an identical text or by endorsement, at the latest by October 2012, and conflicting national standards shall be withdrawn at the latest by October 2012.

Attention is drawn to the possibility that some of the elements of this document may be the subject of patent rights. CEN [and/or CENELEC] shall not be held responsible for identifying any or all such patent rights.

This document supersedes EN 14617-4:2005.

Clause 6 has been modified since the last edition of this European Standard.

This European Standard is one of a series of standards for test methods for agglomerated stones which includes the following:

EN 14617-1, *Agglomerated stone — Test methods — Part 1: Determination of apparent density and water absorption*

EN 14617-2, *Agglomerated stone — Test methods — Part 2: Determination of flexural strength (bending)*

EN 14617-4, *Agglomerated stone — Test methods — Part 4: Determination of the abrasion resistance*

EN 14617-5, *Agglomerated stone — Test methods — Part 5: Determination of freeze and thaw resistance*

EN 14617-6, *Agglomerated stone — Test methods — Part 6: Determination of thermal shock resistance*

EN 14617-8, *Agglomerated stone — Test methods — Part 8: Determination of resistance to fixing (dowel hole)*

EN 14617-9, *Agglomerated stone — Test methods — Part 9: Determination of impact resistance*

EN 14617-10, *Agglomerated stone — Test methods — Part 10: Determination of chemical resistance*

EN 14617-11, *Agglomerated stone — Test methods — Part 11: Determination of linear thermal expansion coefficient*

EN 14617-12, *Agglomerated stone — Test methods — Part 12: Determination of dimensional stability*

EN 14617-13, *Agglomerated stone — Test methods — Part 13: Determination of electrical resistivity*

EN 14617-15, *Agglomerated stone — Test methods — Part 15: Determination of compressive strength*

EN 14617-16, *Agglomerated stone — Test methods — Part 16: Determination of dimensions, geometric characteristics and surface quality of modular tiles*

According to the CEN/CENELEC Internal Regulations, the national standards organizations of the following countries are bound to implement this European Standard: Austria, Belgium, Bulgaria, Croatia, Cyprus, Czech Republic, Denmark, Estonia, Finland, France, Germany, Greece, Hungary, Iceland, Ireland, Italy, Latvia, Lithuania, Luxembourg, Malta, Netherlands, Norway, Poland, Portugal, Romania, Slovakia, Slovenia, Spain, Sweden, Switzerland, Turkey and the United Kingdom

EN 14617-4:2012 (E)**1 Scope**

This European Standard specifies a method for determining the abrasion resistance of agglomerated stone products.

2 Normative references

The following documents, in whole or in part, are normatively referenced in this document and are indispensable for its application. For dated references, only the edition cited applies. For undated references, the latest edition of the referenced document (including any amendments) applies.

EN 13373, *Natural stone test methods — Determination of geometric characteristics on units*

ISO 8486-1, *Bonded abrasives — Determination and designation of grain size distribution — Part 1: Macrogrits F4 to F220*

3 Principle of the test method

The test method is based on scraping off the upper face of the agglomerated stone specimen using an abrasive material under standard conditions.

iTeh STANDARD PREVIEW
(standards.iteh.ai)

4 Abrasive material

The abrasive required for this test is corundum (white fused aluminium oxide, i.e. alumina) with grit size of F80 according to standard ISO 8486-1. It shall not be ~~used more than three times~~.

<https://standards.iteh.ai/catalog/standards/sist/99ff1438-7e94-41fa-a247-a76f7a9600e1/sist-en-14617-4-2012>

5 Apparatus

The wearing machine is of the type of Figure 1, which consists of a rotating abrasion wheel, a storage hopper with one or two control valves to regulate the feed of the abrasive material into a flow guidance hopper, a clamping trolley, a counterweight and a device measuring the number of revolutions.

Whenever two valves are used, one, which can be permanently set, shall be used to control the flow rate of corundum, while the other one is used to turn the flow on and off.

The hardness of the steel shall be 203 HB to 245 HB. Its diameter shall be (200 ± 1) mm and its edge thickness (10 ± 1) mm. It shall be driven to a rotation speed of 75 rotations in (60 ± 3) s.

A mobile clamping trolley is mounted on bearings and forced to press the test specimen against the wheel by a counterweight of constant mass.

The storage hopper containing the abrasive material feeds a flow guidance hopper.

The flow guidance hopper (cylindrical or rectangular) shall have a slotted outlet: the length of the slot shall be (9 ± 1) mm and the width shall be adjustable. The body of the flow guidance hopper shall be at least 10 mm bigger than the slot in all directions (though this is not required in the case of a rectangular hopper with at least one of the sides inclined down to the length (see Figure 2, Example B)).

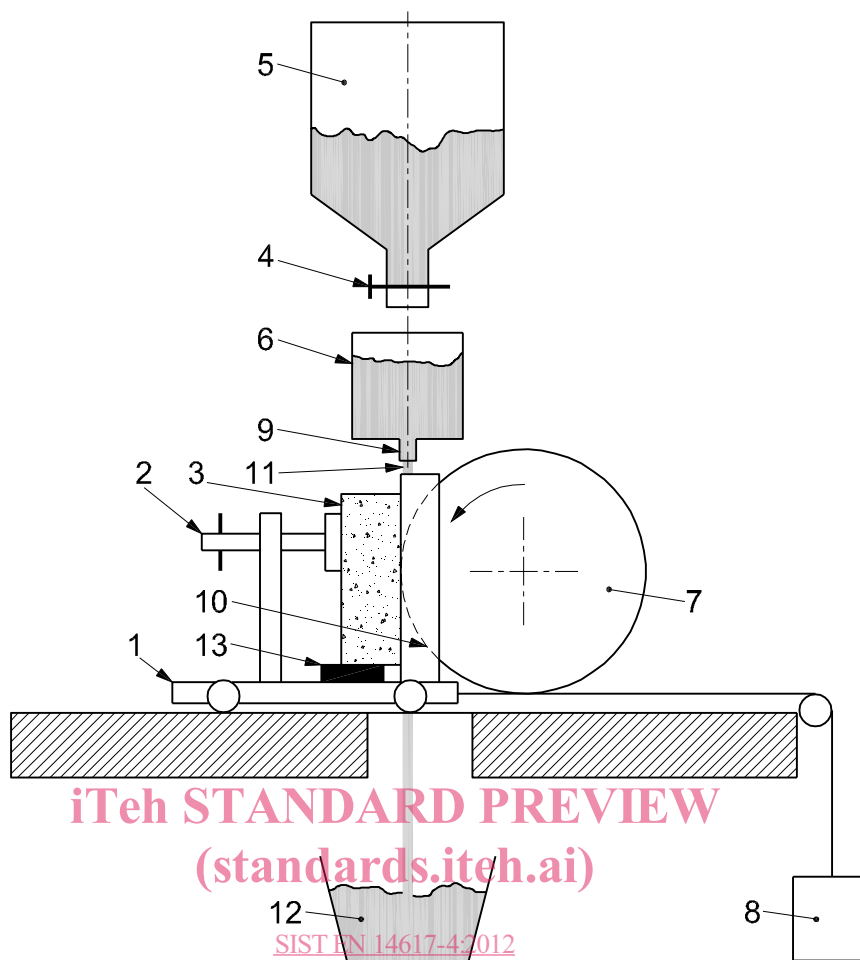

iTeh STANDARD PREVIEW
(standards.iteh.ai)

SIST EN 14617-4:2012

<https://standards.iteh.ai/catalog/standards/sist/99ff1438-7e94-41fa-a247-a76f7a9600e1/sist-en-14617-4-2012>

Key

- 1 clamping trolley
- 2 fixing screw
- 3 specimen
- 4 control valve
- 5 storage hopper
- 6 flow guidance hopper
- 7 abrasion wheel
- 8 counterweight
- 9 flow guidance slot
- 10 groove
- 11 abrasive material flow
- 12 abrasive collector
- 13 wedge

Figure 1 — Principle of wearing machine

The distance of the fall between the slot and the axle of the abrasion wheel shall be (100 ± 5) mm, and the flow of abrasive material shall be 1 mm to 5 mm behind the leading edge of the wheel (see Figure 3).

The minimum flow rate of the abrasive material through the flow guidance slot shall be 100 g/100 revolutions onto the abrasion wheel. The flow rate of abrasive material shall be constant, and the minimum level of the abrasive in the flow guidance hopper shall be 25 mm (see Figure 3).

In addition, the following apparatuses are needed: a magnifying glass (preferably equipped with a light), a steel ruler and a digital calliper.

Dimensions in millimetres

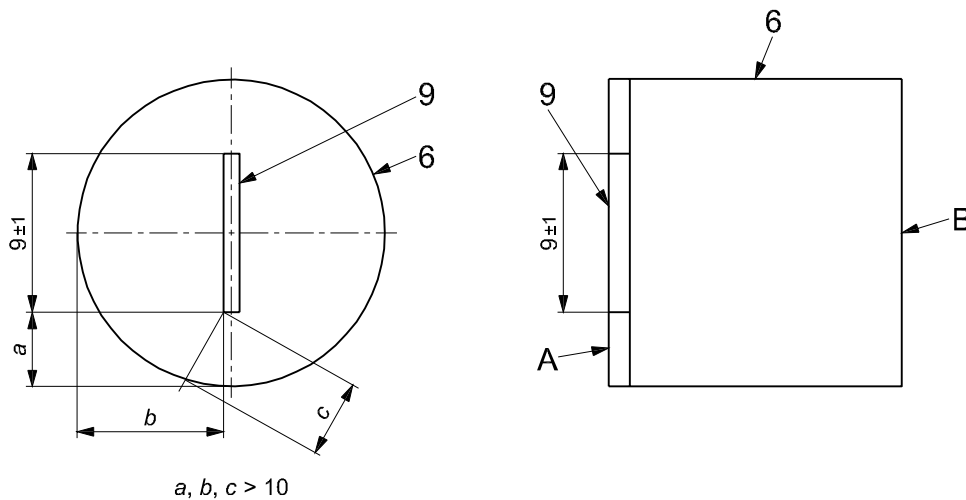

Key

- A inclined side
- B vertical side (for key see Figure 1)

Figure 2 — Slot position in the flow guidance hopper (for key see Figure 1)
 (standards.iteh.ai)

Dimensions in millimetres

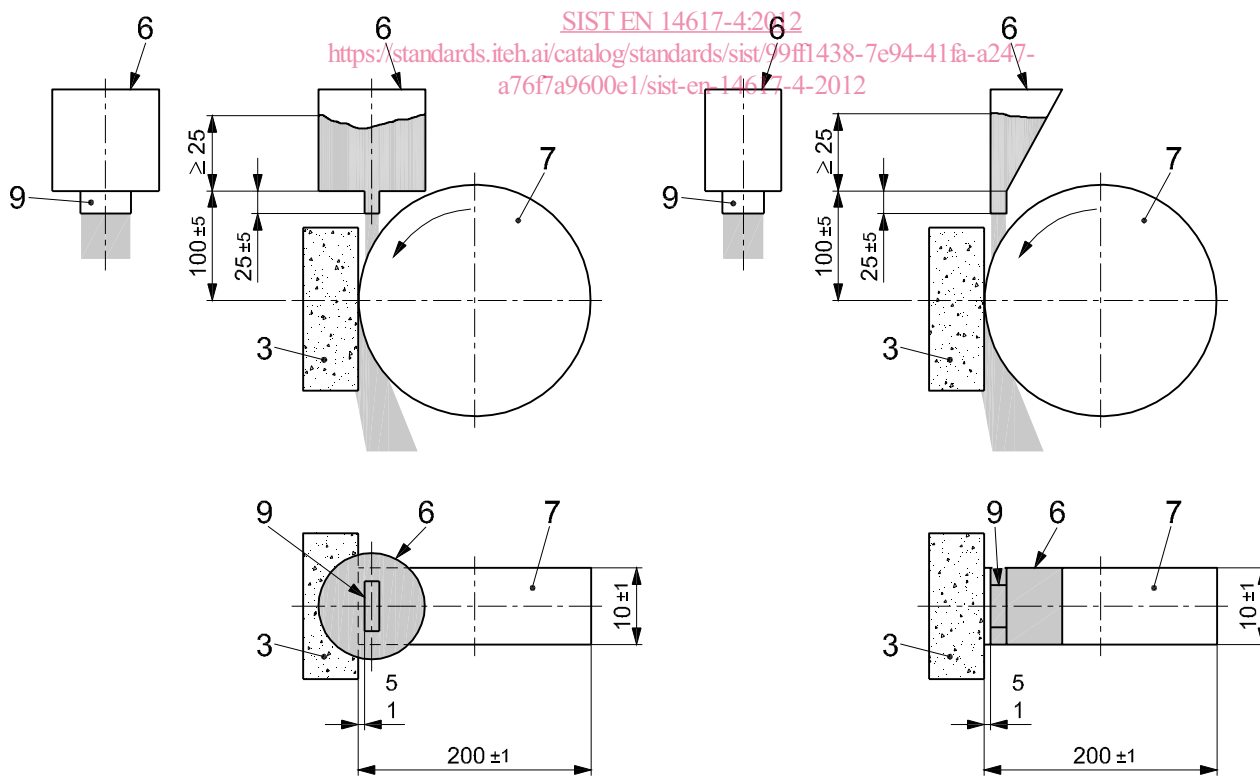

Figure 3 — Position slot relative to abrasion wheel (for key see Figure 1)

6 Calibration

The apparatus shall be calibrated either after grinding 400 grooves or after every two months, whichever is the lesser and every time there is a new operator, a new abrasive batch or a new abrasion wheel.

The abrasive flow rate shall be verified by pouring the abrasive material from a height of approximately 100 mm into a pre-weighed rigid container with a smooth rim, a height of (90 ± 10) mm and a known volume (approximately 1 litre). As the container fills, the pourer shall be raised so as to approximately maintain the 100 mm fall. When the container is filled, the top shall be struck off level and weighed to determine the mass of abrasive for a known volume, i.e. the density. The abrasive shall then be run through the wearing machine and collected below the abrasion wheel in a pre-weighed container, the regularity of the corundum flow during the test checked approximately every 100 g/100 revolutions.

The apparatus shall be calibrated against a reference sample of "glass float" using the procedure in 8.1 with the counterweight adjusted so that after 150 revolutions of the wheel at a rotation rate of 75 rotations in (60 ± 3) s the length of the groove produced is $31,5 \text{ mm} \pm 0,5 \text{ mm}$. The counterweight should be increased or decreased to increase or decrease the groove length respectively. The clamping trolley/counterweight assembly should be checked for undue friction.

The groove shall be measured using the procedure in 8.2 to the nearest 0,1 mm, and the three results averaged to give the calibration value.

An alternative material, such as fused quartz, may be used for the reference sample if a good correlation is established with a reference sample of "glass float".

At every calibration of the apparatus, the squareness of the sample supports shall be checked.

The groove on the reference sample shall be rectangular with a difference between the measured length of the groove at either side not exceeding 0,5 mm. If necessary, check that:

- the sample has been held perpendicular to the wheel;
- the clamping trolley and the flow guidance slot are parallel to the wheel axle;
- the flow of abrasive is even across the slot;
- the friction in the trolley/counterweight assembly is not excessive.

7 Test specimen preparation

7.1 Sampling

Sampling is not the responsibility of the test laboratory, unless otherwise agreed. It shall be appropriately assigned to the agglomerated stone consignment. Whenever possible, the random sampling method shall be used. Test specimens shall be, however, representative of the agglomerated stone sample: they shall be taken from manufactured slabs incorporating the upper face of the sample and cut to the proper size for the measuring apparatus (minimum size $100 \text{ mm} \times 70 \text{ mm}$). At least six specimens shall be selected from a homogeneous batch consisting of the same material and geometric shape.

7.2 Specimens preparation

The test specimen shall be clean and dry.

The upper face, which shall be tested, shall be flat within a tolerance of $\pm 1 \text{ mm}$ and measured according to EN 13373 in two perpendicular directions over 100 mm.