



Designation: D 2013 – 01

Standard Practice for Preparing Coal Samples for Analysis¹

This standard is issued under the fixed designation D 2013; the number immediately following the designation indicates the year of original adoption or, in the case of revision, the year of last revision. A number in parentheses indicates the year of last approval. A superscript epsilon (ϵ) indicates an editorial change since the last revision or reapproval.

1. Scope

1.1 This practice² covers the reduction and division of gross or divided samples up to and including the individual portions for laboratory analysis.

1.2 Reduction and division procedures are prescribed for coals of the following groups:

1.2.1 *Group A* includes coals that have been cleaned in all sizes.

1.2.2 *Group B* includes all other coals. Unknown coals are to be considered under Group B.

1.2.3 Group A allows smaller weight laboratory samples to be retained than Group B. These lower weights may be used for particular coals if they have been shown, by using the procedures of Annex A1.2, to give a sample preparation and analysis variance which is no more than 20 % of the total analysis variance.

1.3 *This standard does not purport to address all of the safety concerns, if any, associated with its use. It is the responsibility of the user of this standard to establish appropriate safety and health practices and determine the applicability of regulatory limitations prior to use.*

1.4 The values stated in SI units are to be regarded as standard. The values given in parentheses are provided for information purposes only.

2. Referenced Documents

2.1 ASTM Standards:

D 121 Terminology of Coal and Coke³

D 197 Test Method for Sampling and Fineness Test of Pulverized Coal³

D 2234 Practice for Collection of a Gross Sample of Coal³

D 3174 Test Method for Ash in the Analysis Sample of Coal and Coke from Coal³

D 3302 Test Method for Total Moisture in Coal³

D 4749 Test Method for Performing the Sieve Analysis of

Coal and Designating Coal Size³

E 11 Specification for Wire-Cloth Sieves for Testing Purposes⁴

E 177 Practice for Use of the Terms Precision and Bias in ASTM Test Methods⁴

E 456 Terminology Relating to Quality and Statistics⁴

3. Terminology

3.1 *Definitions of Terms Specific to This Standard*—No terms are used which are specific to this practice. Many terms used in this practice may be found in Terminologies D 121 and E 456 and in Practice E 177.

4. Summary of Practice

4.1 Three processes of sample division and reduction are covered as follows:

4.1.1 *Procedure A*—Manual riffles are used for division of the sample and mechanical crushing equipment for the reduction of the sample.

4.1.2 *Procedure B*—Mechanical sample dividers are used for the division of the sample and mechanical crushing equipment for the reduction of the sample.

4.1.3 *Combined Procedure A and B*—The two procedures may be combined at any stage.

5. Significance and Use

5.1 Other standards are used to collect the gross sample: Practice D 2234 allows for one division of the gross sample before crushing. The mass and top size of the gross or divided sample collected by using these guides and practices are usually too large for chemical or physical testing. Practice D 2013 provide instructions for reducing and dividing the gross or divided sample, by on-line or off-line processes, or both, to a top size and mass suitable to the performance of testing. Any bias in the gross or divided sample before adherence to this practice will remain in the final sample resulting from use of this practice. Therefore, carefully select the standard to be used to collect the gross sample.

5.2 Division and reduction of a sample may occur at more than one location. Most often, the sample is collected, reduced,

¹ This practice is under the jurisdiction of ASTM Committee D05 on Coal and Coke and is the direct responsibility of Subcommittee D05.23 on Sampling.

Current edition approved Nov. 10, 2001. Published January 2002. Originally published as D 2013 – 62 T. Last previous edition D 2013 – 00a^{ε1}.

² For more detailed explanation of this practice see Keller, G. E., "Determination of Quantities Needed in Coal Sample Preparation and Analysis," *Transactions*, Vol 232, 1965, pp. 218-226.

³ *Annual Book of ASTM Standards*, Vol 05.06.

⁴ *Annual Book of ASTM Standards*, Vol 14.02.

and divided (one or more times) by use of a mechanical sampling system. The remaining sample may be further divided on-site to facilitate transporting it to the laboratory where further reduction and division likely occurs before analysis.

5.3 In places, this practice requires air drying the sample before subsequent reduction. Procedures for air drying and air-dry loss determination are provided in Test Method D 3302.

5.4 Most often, samples are reduced and divided to an analysis sample. However, some tests may require a sample of different mass or top size. This procedure may be used to provide a sample of any mass and size consist from the gross or divided sample to, and including, the analysis sample.

6. Apparatus

6.1 *Crushers or Grinders*—Jaw, cone, or rotary crusher; hammer mill; roll; or other suitable crusher to reduce the sample to pass the sieve designated in 6.4. Hard steel or chilled iron plate with tamper, sledge, or hand bar may be used for preliminary crushing of any large lumps in the sample before feeding into the crusher. Crushers should be designed and operated in a manner to minimize the effect of induced air circulation and thus the potential for drying the coal.

6.1.1 *Pulverizer or Mill*—For final reduction of laboratory sample to the 250- μm (No. 60) sieve size, the following equipment may be used:

6.1.2 *Hammer Mill*—Completely enclosed to avoid loss of dust or moisture.

6.1.3 *Porcelain-Jar Ball Mill*—This mill shall be approximately 230 mm (9.0 in.) in diameter and 250 mm (10.0 in.) in height with smooth, hard, well-rounded, flint pebbles, or equivalent, that do not increase ash content of the sample.

6.1.4 *Bucking Board (Chrome Steel) or Mortar (Agate or Equivalent) and Pestle*—Only for reducing the small fraction of sample, not passing a 250- μm (No. 60) sieve after pulverization.

6.2 *Sample Dividers:*

6.2.1 *Mechanical*—A mechanical sample divider using a reciprocating or rotating cutter, a rotating hopper and spout, a rotating slotted cone, a reciprocating hopper and fixed cutter, bucket cutter with either bottom dump or inverting discharge, slotted belt, rotary disk divider, mechanical stopped or moving belt sweeper, or other acceptable devices for dividing the sample. Typical mechanical sample dividers are shown in Fig. 1. These illustrate various designs, but other acceptable designs are available.

6.2.2 *Riffle*—A manual sample divider that splits the coal stream into a number of alternate elements. Riffle slots should be at least three times the top size of coal being divided. A typical riffle is shown in Fig. 2. It is preferable that feed chutes and enclosed riffles be used. The slope of feed chutes and riffles must be at least 60°.

6.2.2.1 *Feed Scoop*—A feed scoop or pan having straight sides and a width equal to the effective width of the riffle shall be used to feed the riffle.

6.2.2.2 *Feed Chute*—A feed chute shall be used as shown in Fig. 2. The minimum discharge opening of the feed chute shall be the same width as the riffle slot opening.

6.3 *Mixing Wheel*—One type of a mechanical device used for mixing the analysis sample. In this device, the samples are

in closed containers attached to the rim of a wheel at an angle of 45° with the horizontal wheel shaft. The wheel provides space for a number of containers depending on its diameter and is turned slowly by a small motor and reduction gear. The wheel should be rotated at a speed so that the particles fall gently from top to bottom of the container, mixing the sample thoroughly. The container should be about half full and never more than two thirds full to obtain good mixing of the sample.

6.4 *Sieves*—A set of sieves whose dimensions are in accordance with Specification E 11, of the following sizes, with cover and receiver:

No.	Size
4	4.75 mm
8	2.36 mm
20	850 μm
60	250 μm

6.5 *Laboratory Sample Containers*—Heavy vapor-impervious bags, properly sealed, or noncorroding cans such as those with an airtight top, friction top, or screwtop sealed with a rubber gasket and pressure-sensitive tape for use in storage and transport of the laboratory sample. Glass containers, sealed with rubber gaskets, may be used, but care must be taken to avoid breakage in transport.

7. Precautions

7.1 *General*—The preparation of the gross or divided sample shall be performed by, or under the direct supervision of, personnel knowledgeable of proper sample handling practices. Sample preparation should be checked at intervals by the methods described in Annex A1 or Annex A2. It is necessary that the variance of sample division and analysis S_{da}^2 be not more than 20 % of the total variance of sampling, division, and analysis S_o^2 .

7.1.1 The sample preparation operations should be performed in an enclosed space, roofed, cool, and free from excessive air movements.

7.2 *Number of Tests*—Before preparing the gross or divided sample, the number and nature of the analysis and tests should be considered. A separate moisture laboratory sample may be required, and portions may be required for grindability and other tests. Also, a reserve sample may be desired in case a check analysis or test is required.

7.3 This practice specifies situations when air drying the sample is necessary during sample preparation. Test Method D 3302 specifies procedures for air drying and calculation of percent air dry loss.

7.3.1 Calculate and record air-dry loss determination each time air drying is performed.

7.3.2 In handling, reducing, and dividing the sample, all operations shall be done rapidly and in as few operations as possible, since moisture loss depends on several factors other than total moisture content, such as time required for crushing, atmospheric temperature and humidity, and type of crushing equipment.

7.3.3 While awaiting preparation, the gross or divided sample shall be protected from moisture change as a result of exposure to rain, snow, wind, and sun on contact with absorbent materials.

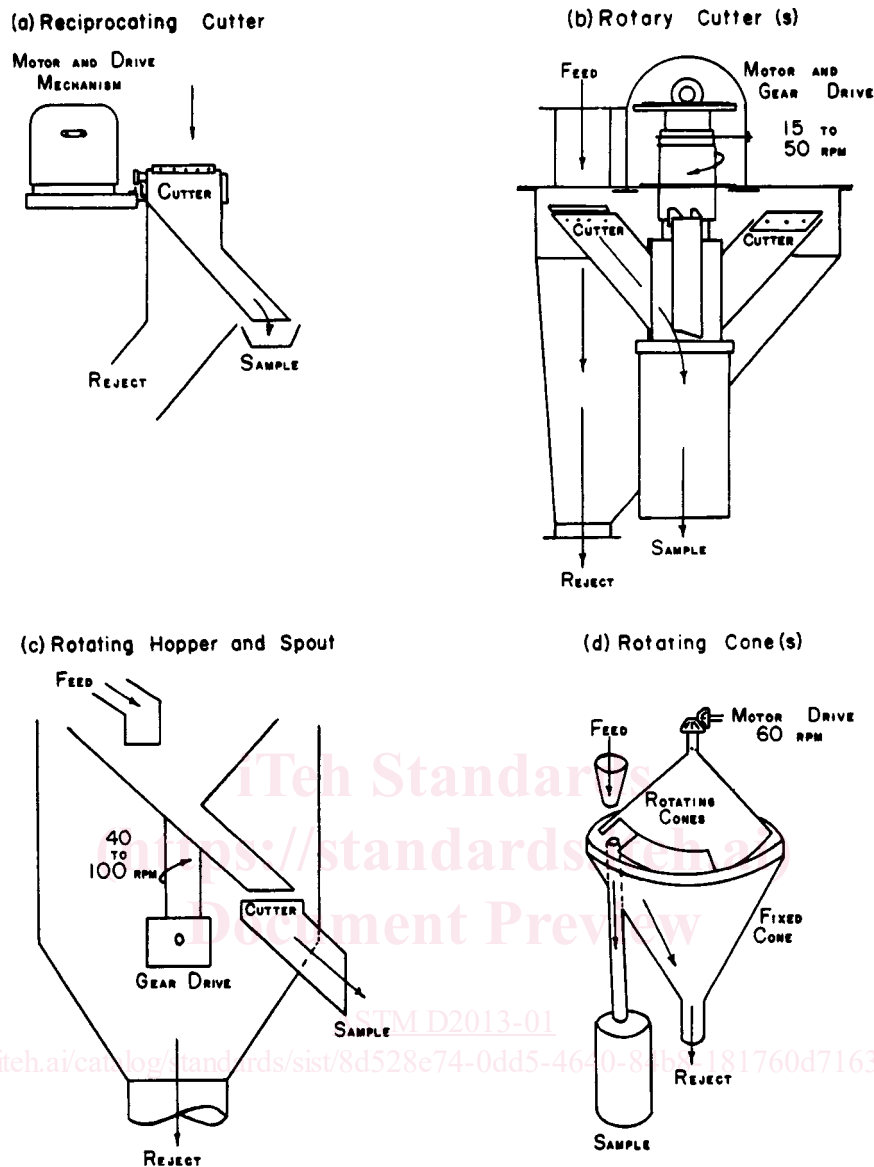

(a) *Reciprocating Cutter*—Fig. 1(a) shows a section of a cutter which is moved across a stream of coal. At regular intervals, the cutter movement is reversed and a sample increment is collected on each trip through the coal stream.

(b) *Rotating Cutter*—Fig. 1(b) shows two cutters attached to a hollow, rotating shaft. Each cutter is designed to extract increments from the feed and to discharge these into the hollow shaft. One or more cutters may be used.

(c) *Rotating Hopper and Spout*—Fig. 1(c) shows the totaling hopper that receives the crushed sample and discharges it through a spout over one or more stationary cutters.

(d) *Rotating Cone*—A sampler developed by the British National Coal Board. Two slotted cones are locked together and rotated on a vertical shaft so that on each revolution the common slot operating intercepts the falling stream of coal and collects an increment.

FIG. 1 Mechanical Sample Dividers

7.3.4 Whenever subsamples are stored or transported, the containers and subsample shall be weighed and equilibrated to the new atmosphere by air drying, and the weight loss or gain shall be used in the calculation of moisture content.

7.4 Whenever a distinct change of humidity occurs during the course of preparation of an air-dried subsample, the subsample shall be weighed and its moisture equilibrated with the new atmosphere, and the loss or gain in mass shall be used in the calculation of moisture content.

8. Sieve Tests

8.1 The errors of sample division are sensitive to the top size, and therefore, it is important to make a periodic sieve test

of the product of the sample crusher. Sieve tests shall be made and reported in accordance with Test Method D 4749, except when more than 50 % passes the No. 8 (2.36-mm) sieve. Sieve tests on the portions passing the No. 8 sieve shall be made in accordance with Test Method D 197.

9. Procedure

9.1 *Mass*—The minimum allowable mass of the sample at any stage depends on the top size, the variability of the constituent sought, and the degree of precision desired (Table 1).

9.2 *Reduction and Division* (See Fig. 3 for flowchart):

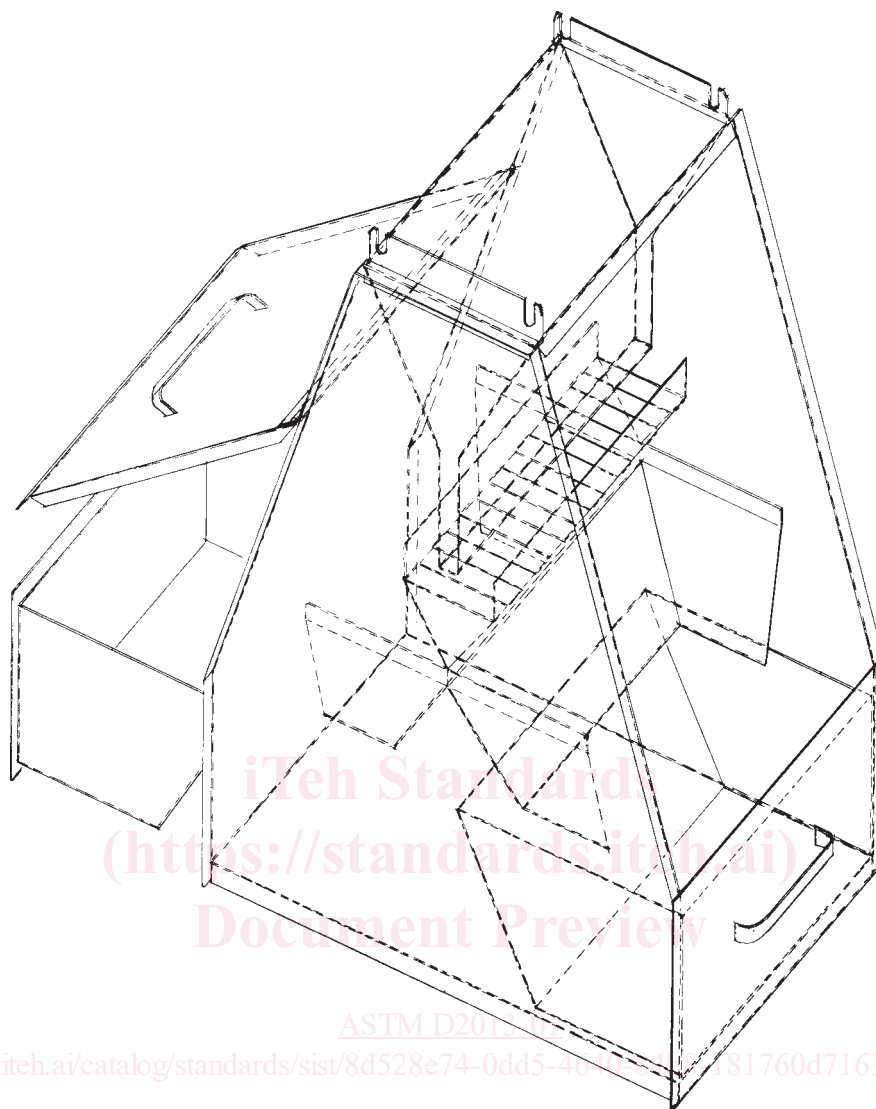

FIG. 2 Sample Divider (Riffle)

TABLE 1 Preparation of Laboratory Sample

Crush to pass at least 95 % through sieve	Divide to a minimum weight of, g ^A	
	Group A	Group B
No. 4 (4.75-mm)	2000	4000
No. 8 (2.36-mm)	500	1000
No. 20 (850 µm)	250	500
No. 60 (250 µm) (100 % through)	50	50

^A If a moisture sample is required, increase the quantity of No. 4 (4.75-mm) or No. 8 (2.36-mm) sieve subsample by 500 g.

9.2.1 It is permissible to air dry the sample before crushing. Samples may require air drying to feed properly through the reduction and dividing equipment. Sometimes there is an interest in determining the air-dry loss value before crushing. Air dry in accordance with Test Method D 3302.

9.2.2 In the reduction and division of gross or divided samples for which total moisture content is to be determined, the precautions in 7.3 and 7.4 must be followed.

9.2.3 Procedure A—Manual Riffling:

9.2.3.1 Reduce the gross or divided sample to a top size of 4.75-mm (No. 4) or 2.36-mm (No. 8) sieve taking precautions in accordance with Section 7.

9.2.3.2 Determine the number of passes required in the riffling operation from the total mass of the gross sample and the minimum permissible mass in accordance with Table 1.

9.2.3.3 Divide the crushed sample by using a large riffle. Riffles properly used will reduce sample variability but cannot eliminate it. A typical enclosed riffle is shown in Fig. 2 and described in 6.2.2. Pass the coal through the riffle from a feed scoop, feed bucket, or riffle pan having a lip or opening the full width of the riffle. When using any of the preceding containers to feed the riffle, spread the coal evenly in the container, raise the container, and hold it with its front edge resting on top of the feed chute, then slowly tilt it so that the coal flows in a uniform stream through the hopper straight down over the center of the riffle into all the slots, then into the riffle pans, one half of the sample being collected in each pan. Under no circumstances shovel the sample into the riffle or dribble into the riffle from a small-mouthed container. Do not allow the

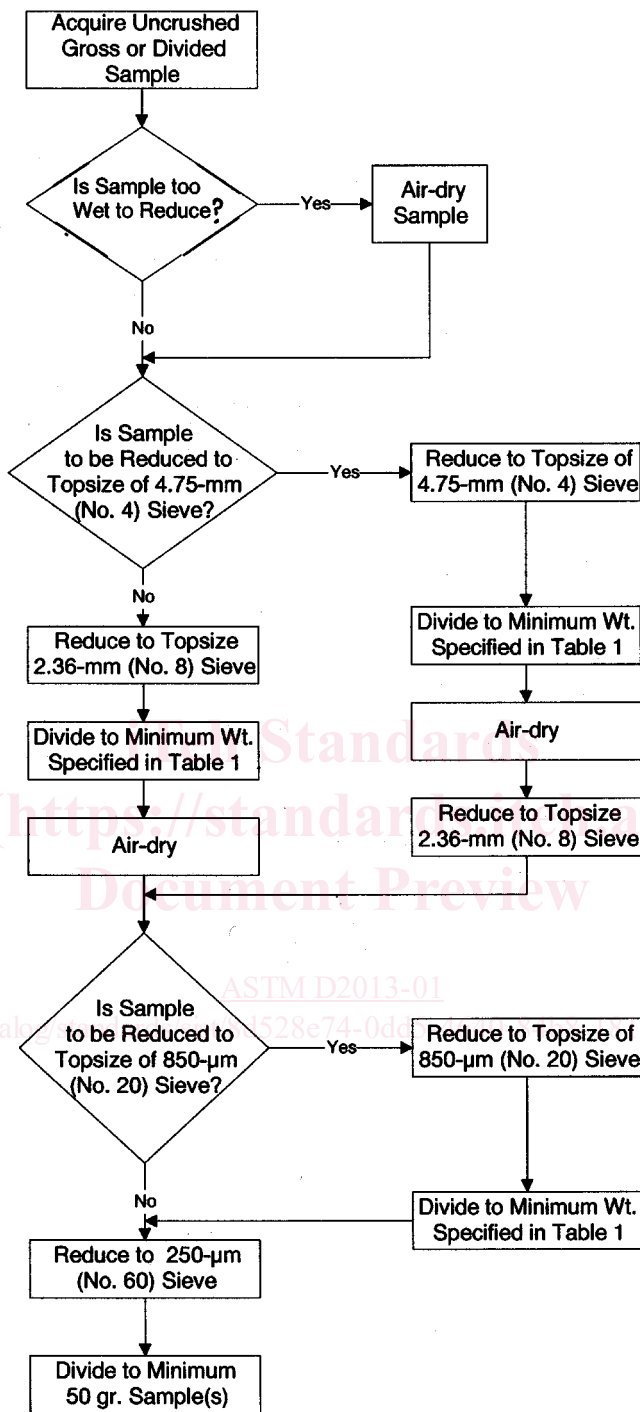

FIG. 3 Sample Preparation Flowchart

coal to build up in or above the riffle slots. If it does not flow freely through the slots, shake or vibrate the riffle to facilitate even flow.

9.2.3.4 If the initial crushing was only to 4.75-mm (No. 4) sieve size, reduce to 2.36-mm (No. 8) sieve size after dividing to no less than the quantity specified in Table 1 for a 4.75-mm (No. 4) sieve size.

9.2.3.5 After reducing to 2.36-mm (No. 8) sieve size, divide the subsample by riffing to no less than the quantity specified in Table 1 for a 2.36-mm sieve size.

9.2.3.6 With suitable pulverizing equipment (see 6.1), reduce the 2.36-mm (No. 8) sieve size subsample to a 250-µm (No. 60) sieve size. Divide the ground subsample by riffing, using the small riffle (see 6.2.2) until a minimum of 50 g is



obtained. Quickly pass the subsample through a 250- μm (No. 60) sieve. Reduce the particles retained on the screen, on a bucking board or mortar and pestle to pass the sieve, and add to what passed through the sieve and mix thoroughly. This is the analysis sample.

9.2.3.7 As an alternative to the procedure of 9.2.3.6, the 2.36-mm (No. 8) sieve size subsample may be reduced to pass 95 % through a 850- μm (No. 20) sieve. Divide this subsample by riffing with the small riffle to not less than the quantity specified in Table 1, and then reduce to 250- μm (No. 60) sieve size in accordance with 9.2.3.6.

9.2.3.8 Thoroughly mix, preferably by mechanical means, the analysis sample, weighing not less than 50 g, before extracting portions for analysis (see 6.3).

9.2.4 *Procedure B—Mechanical Division:*

9.2.4.1 Reduce the gross or divided sample in stages and divide by suitable mechanical sample dividers (see 6.2.1) to quantities not less than those shown in Table 1.

9.2.4.2 Mechanical division of the sample consists of automatically collecting a large number of increments of the properly reduced sample. Distribute this large number of

increments equally throughout the entire discharge from the sample crusher because crushers can introduce appreciable segregation. At each stage of division, take at least 60 increments.

NOTE 1—It is recommended that, in the case of mechanical division in which an increment is not thoroughly mixed with other increments before division, a portion of each increment be collected by the subsequent stage increment collection process.

9.2.4.3 Thoroughly mix the analysis sample, 100 % through 250- μm (No. 60) sieve and weighing not less than 50 g, in accordance with 9.2.3.8 before extracting portions for analysis.

10. Precision and Bias

10.1 The precision of sample preparation (and analysis) can be checked by Annex A1 and Annex A2. Since this practice does not produce a numerical result, determination of bias is not applicable.

11. Keywords

11.1 coal; division; reduction

iTeh Standards (<https://standards.iteh.ai>) Document Preview

[ASTM D2013-01](#)

<https://standards.iteh.ai/catalog/standards/sist/8d528e74-0dd5-4640-84b8-181760d71636/astm-d2013-01>