



SLOVENSKI STANDARD

SIST EN 16430-3:2015

01-marec-2015

Končni prenosniki toplote z ventilatorjem, konvektorji in talni konvektorji - 3. del: Preskusne metode in vrednotenje hladilne moči

Fan assisted radiators, convectors and trench convectors - Part 3: Test method and rating for cooling capacity

Gebälseunterstützte Heizkörper, Konvektoren und Unterflurkonvektoren - Teil 3:
Prüfverfahren und Bewertung der Kühlleistung

Radiateurs assistés par ventilateur, convecteurs et convecteurs de caniveaux - Partie 3:
Méthode d'essais et d'évaluation de la puissance thermique en mode rafraîchissement

[https://standards.iteh.ai/catalog/standards/sist/79b2b3d0-4574-441d-](https://standards.iteh.ai/catalog/standards/sist/79b2b3d0-4574-441d-a917-c3834af8183f/sist-en-16430-3-2015)

Ta slovenski standard je istoveten z: **EN 16430-3:2014**

ICS:

91.140.10	Sistemi centralnega ogrevanja	Central heating systems
-----------	-------------------------------	-------------------------

SIST EN 16430-3:2015

en,fr,de

iTeh STANDARD PREVIEW
(standards.iteh.ai)

SIST EN 16430-3:2015

<https://standards.iteh.ai/catalog/standards/sist/79b2b3d0-4574-441d-a917-c3834af8183f/sist-en-16430-3-2015>

EUROPEAN STANDARD

EN 16430-3

NORME EUROPÉENNE

EUROPÄISCHE NORM

December 2014

ICS 91.140.10

English Version

Fan assisted radiators, convectors and trench convectors - Part 3: Test method and rating for cooling capacity

Radiateurs assistés par ventilateur, convecteurs et convecteurs de caniveaux - Partie 3: Méthode d'essais et d'évaluation de la puissance thermique en mode rafraîchissement

Gebläseunterstützte Radiatoren, Konvektoren und Unterflurkonvektoren - Teil 3: Prüfverfahren und Bewertung der Kühlleistung

This European Standard was approved by CEN on 9 November 2014.

CEN members are bound to comply with the CEN/CENELEC Internal Regulations which stipulate the conditions for giving this European Standard the status of a national standard without any alteration. Up-to-date lists and bibliographical references concerning such national standards may be obtained on application to the CEN-CENELEC Management Centre or to any CEN member.

This European Standard exists in three official versions (English, French, German). A version in any other language made by translation under the responsibility of a CEN member into its own language and notified to the CEN-CENELEC Management Centre has the same status as the official versions.

CEN members are the national standards bodies of Austria, Belgium, Bulgaria, Croatia, Cyprus, Czech Republic, Denmark, Estonia, Finland, Former Yugoslav Republic of Macedonia, France, Germany, Greece, Hungary, Iceland, Ireland, Italy, Latvia, Lithuania, Luxembourg, Malta, Netherlands, Norway, Poland, Portugal, Romania, Slovakia, Slovenia, Spain, Sweden, Switzerland, Turkey and United Kingdom.

<https://standards.iteh.ai/catalog/standards/sist/79b2b3d0-4574-441d-a917-c3834af8183f/sist-en-16430-3-2015>



EUROPEAN COMMITTEE FOR STANDARDIZATION
COMITÉ EUROPÉEN DE NORMALISATION
EUROPÄISCHES KOMITEE FÜR NORMUNG

CEN-CENELEC Management Centre: Avenue Marnix 17, B-1000 Brussels

Contents	Page
Foreword.....	3
1 Scope	4
2 Normative references	4
3 Terms and definitions	4
4 Testing of dry cooling capacity.....	5
4.1 Short description	5
4.2 Test booth.....	5
4.3 Test methods.....	7
4.3.1 General.....	7
4.3.2 Fan assisted radiators / convectors	8
4.4 Master radiator for dry cooling capacity	12
5 Carrying out the measurements.....	13
5.1 Dimension and construction of the test samples	13
5.2 Selection of the models to be tested for determining the dry cooling capacity of a type	13
5.3 Installation of the sample in the test booth	13
5.3.1 General.....	13
5.3.2 Radiators and wall-mounted convectors	14
5.3.3 Trench convectors.....	14
5.4 Connection of the test sample to the measuring circuit	14
5.5 Minimum dry cooling performance	14
5.6 Mass flow rate	14
5.7 Reference air temperature	14
5.8 Steady state conditions	14
5.9 Correction due to air pressure	15
5.10 Results of measurements – characteristic equation	15
6 Test Report	15
6.1 General.....	15
6.2 Data	15

Iteh STANDARD PREVIEW
(standards.iteh.ai)

Foreword

This document (EN 16430-3:2014) has been prepared by Technical Committee CEN/TC 130 "Space heating appliances without integral heat sources", the secretariat of which is held by UNI.

This European Standard shall be given the status of a national standard, either by publication of an identical text or by endorsement, at the latest by June 2015 and conflicting national standards shall be withdrawn at the latest by June 2015.

Attention is drawn to the possibility that some of the elements of this document may be the subject of patent rights. CEN [and/or CENELEC] shall not be held responsible for identifying any or all such patent rights.

The European Standard "Fan assisted radiators, convectors and trench convectors" consists of the following parts:

- Part 1: Technical specifications and requirements
- Part 2: Test method and rating for thermal output
- Part 3: Test method and rating for cooling capacity

According to the CEN-CENELEC Internal Regulations, the national standards organizations of the following countries are bound to implement this European Standard: Austria, Belgium, Bulgaria, Croatia, Cyprus, Czech Republic, Denmark, Estonia, Finland, Former Yugoslav Republic of Macedonia, France, Germany, Greece, Hungary, Iceland, Ireland, Italy, Latvia, Lithuania, Luxembourg, Malta, Netherlands, Norway, Poland, Portugal, Romania, Slovakia, Slovenia, Spain, Sweden, Switzerland, Turkey and the United Kingdom.

[SIST EN 16430-3:2015](https://standards.itech.ai/catalog/standards/sist/79b2b3d0-4574-441d-a917-c3834af8183f/sist-en-16430-3-2015)

<https://standards.itech.ai/catalog/standards/sist/79b2b3d0-4574-441d-a917-c3834af8183f/sist-en-16430-3-2015>

EN 16430-3:2014 (E)**1 Scope**

This European Standard applies to the testing of the dry cooling capacity with no condensation of fan assisted radiators, convectors and trench convectors which are factory assembled or kits, i.e.

- fan assisted radiators and convectors, provided the cooler has a dedicated fan or fans;
- radiators and convectors without dedicated fan(s);
- trench convectors with and without fan(s), provided the cooler and the fan(s) are dedicated.

2 Normative references

The following documents, in whole or in part, are normatively referenced in this document and are indispensable for its application. For dated references, only the edition cited applies. For undated references, the latest edition of the referenced document (including any amendments) applies.

EN 442-2, *Radiators and convectors - Part 2: Test methods and rating*

EN 16430-2, *Fan assisted radiators, convectors and trench convectors — Part 2: Test method and rating for thermal output*

EN ISO/IEC 17025, *General requirements for the competence of testing and calibration laboratories (ISO/IEC 17025)*

iTeh STANDARD PREVIEW
(standards.iteh.ai)

3 Terms and definitions

For the purposes of this document, the terms and definitions given in EN 442-2 and the following apply.

[SIST EN 16430-3:2015](https://standards.iteh.ai/catalog/standards/sist/en-16430-3-2015)

3.1 <https://standards.iteh.ai/catalog/standards/sist/79b2b3d0-4574-441d-a917-c3834af8183f/sist-en-16430-3-2015>

trench convectors

convectors installed in a trench (in the floor) mostly in front of glass facades, including the covering of the trench

3.2**fan assisted radiators and convectors**

radiators and convectors according to EN 442-2 and trench convectors according to 3.1 equipped with fans to increase the convective thermal output/ dry cooling capacity of the radiator, convector or trench convector

3.3**basic units**

regularly repeated sections of the radiator/convector equipped with fans

3.4**extension units**

parts of the fan assisted radiator/convector in addition to the basic units which are not equipped with a fan

3.5**dry cooling capacity**

thermal performance of the appliance in dry cooling operation.

3.6**standard dry cooling capacity**

dry cooling capacity defined at an under temperature of 10 K

3.7

under temperature

difference between the reference air temperature and the mean water temperature

4 Testing of dry cooling capacity

4.1 Short description

The dry cooling capacity of the test sample has to be determined in its steady state with measurements of the cooling water flow and the temperature difference in the cooling water. The dry cooling capacity shall be quoted as a function of the temperature difference between the reference temperature and the average cooling water temperature.

The test is carried out in a testing system according to EN 442-2, which consists of a closed booth with controlled temperatures of the inside surfaces and a secondary master radiator for dry cooling capacity (see 4.4). All laboratories performing tests according to this standard shall participate in inter-laboratory comparison exercises (according to EN 442-2).

To balance the dry cooling capacity, the test booth will be heated with a number of electrically heated dry cooling load simulators which are positioned on the floor of the test booth. To obtain reproducible results, the simulators shall be arranged according to 4.2.

4.2 Test booth

The test is carried out in a test booth according to EN 442-2. In deviation from these definitions the surfaces, floor and ceiling of the test booth shall be insulated in such a way as that the average heat flow in those surfaces is lower than 0,40 W/m² during the test. This heat flow shall be determined by preliminary calibration tests of the booth or by calculations.

In deviation from EN 442-2, the reference air temperature shall be 28 °C ± 0,5 K during the measurement.

The temperature of the metal surfaces under the insulation of the walls, floor and ceiling of the test booth shall be regulated and be maintained at a value, which is necessary to guarantee a max. temperature difference between these surfaces and the reference air temperature of less than 1,0 K.

The radiant emissivity of the surface of the insulation shall be at least 0,9.

The test booth will be heated with 10 electrically heated dry cooling load simulators (see Figure 1), which are positioned on the floor of the test booth. The dimension of "a" in Figure 1 depends on the thickness of the inner wall insulation.

The output of each simulator shall not exceed 180 W and shall be continually variable.

The housing of the simulators consists of painted sheet steel. The emissivity of the inside and outside surfaces shall be at least 0,9. The active power of the simulators shall be measured using an instrument with an accuracy class of 1,0 or better.

Dimensions in metres

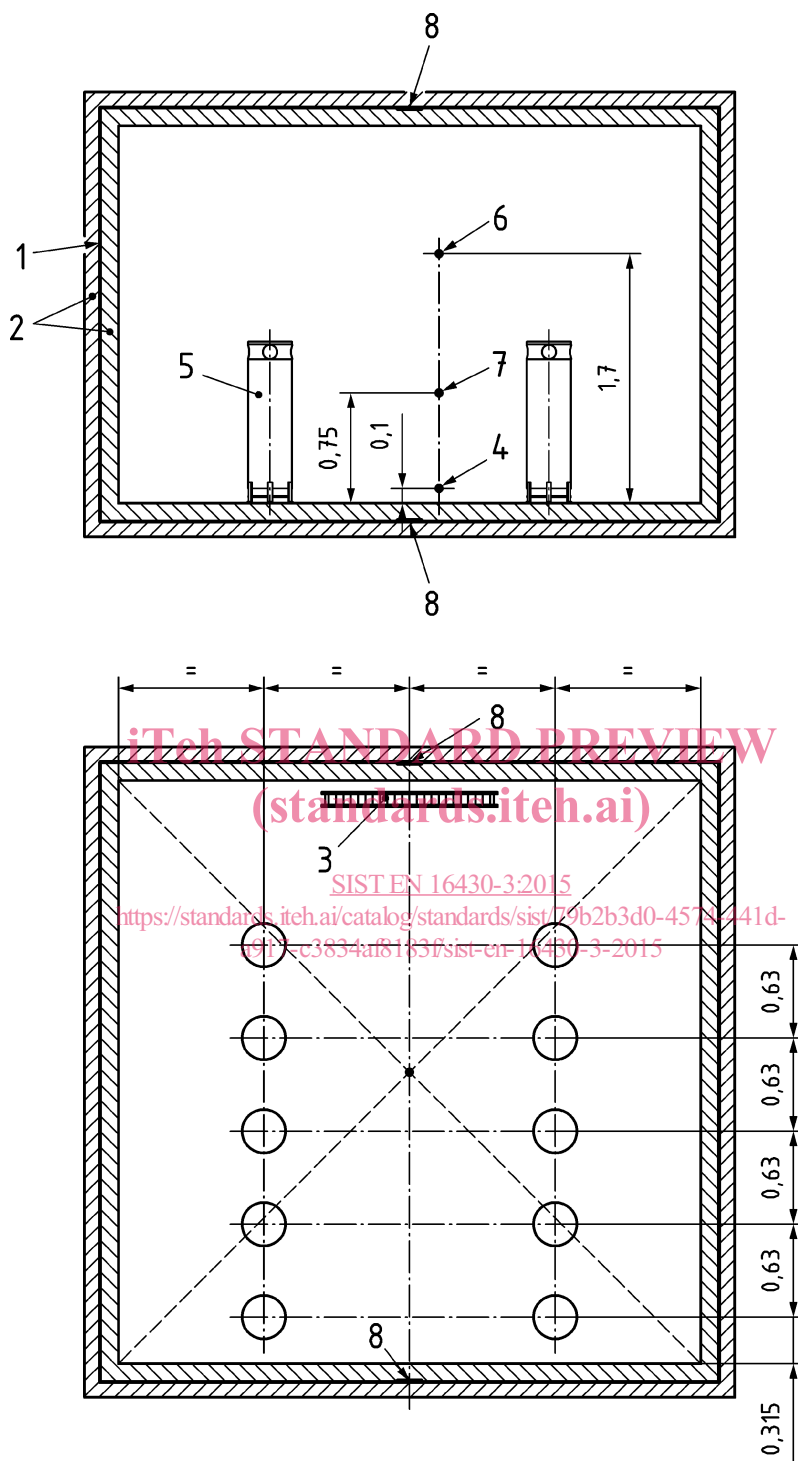
**Key**

- | | | | |
|---|------------------------------------|---|--|
| 1 | water cooled metal panels | 5 | dry cooling load simulator |
| 2 | insulation | 6 | measuring point of air temperature |
| 3 | test panel or convector | 7 | measuring point of reference air temperature |
| 4 | measuring point of air temperature | 8 | measuring point of temperature under insulation (position according to EN 442-2) |

Figure 1 — Test booth with an installed dry cooling convector or radiator, dry cooling load simulators and the measuring points for the temperatures

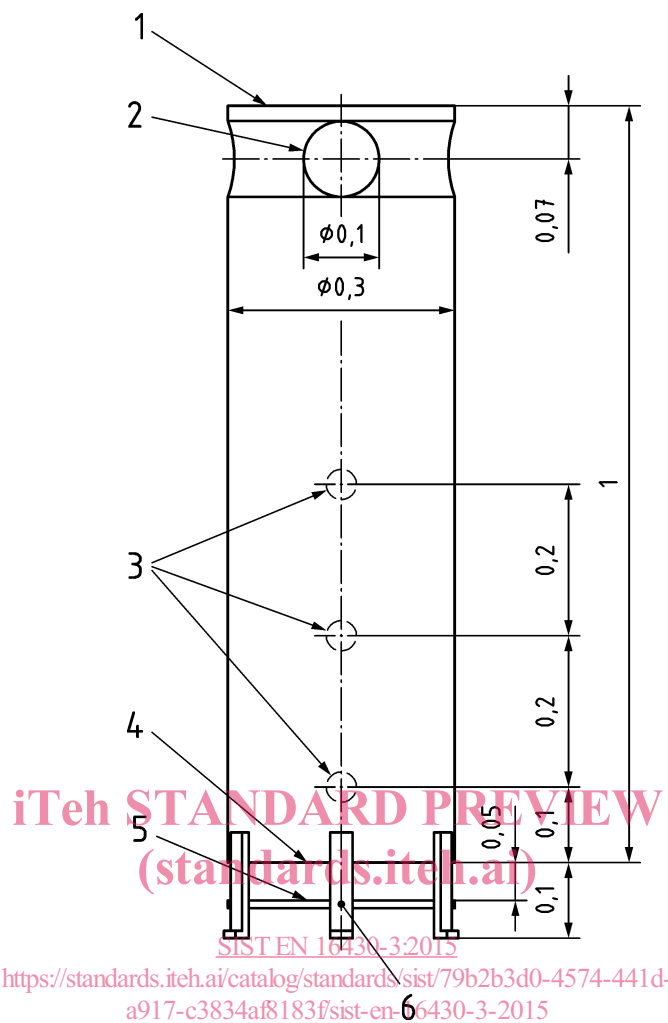
**Key**

- 1 cover
- 2 4 holes, evenly distributed
- 3 60 W heat source
- 4 open
- 5 bottom plate
- 6 support

Figure 2 — Dry cooling load simulator (dummy)**4.3 Test methods****4.3.1 General**

The test method shall be carried out according to EN 442-2.

Analogue to the excess temperatures given, the under temperatures shall be:

$$\Delta T = (8 \text{ K} \pm 0,5) \text{ K}$$

$$\Delta T = (10 \text{ K} \pm 0,5) \text{ K}$$

$$\Delta T = (12 \text{ K} \pm 0,5) \text{ K}$$