



Designation: F 366 – 04

Standard Specification for Fixation Pins and Wires¹

This standard is issued under the fixed designation F 366; the number immediately following the designation indicates the year of original adoption or, in the case of revision, the year of last revision. A number in parentheses indicates the year of last reapproval. A superscript epsilon (ϵ) indicates an editorial change since the last revision or reapproval.

This standard has been approved for use by agencies of the Department of Defense.

1. Scope

1.1 This specification covers functional dimensions for fixation pins and wires.

1.2 In recognition of many broad and varied uses of such pins and wires, many options are included. A variety, but not necessarily all, of the options are illustrated in Figs. 1-3.

1.3 The values stated in inch-pound units are to be regarded as the standard. The values given in parentheses are provided for information only.

2. Referenced Documents

2.1 ASTM Standards:²

F 67 Specification for Unalloyed Titanium for Surgical Implant Applications (UNS R50250, UNS R50400, UNS R50550, UNS R50700)

F 75 Specification for Cobalt-28Chromium-6Molybdenum Alloy Castings and Casting Alloy for Surgical Implants (UNS R30075)

F 86 Practice for Surface Preparation and Marking of Metallic Surgical Implants

F 90 Specification for Wrought Cobalt-20Chromium-15Tungsten-10Nickel Alloy for Surgical Implant Applications (UNS R30605)

F 136 Specification for Wrought Titanium-6Aluminum-4Vanadium ELI (Extra Low Interstitial) Alloy for Surgical Implant Applications (UNS R56401)

F 138 Specification for Wrought-18Chromium-14Nickel-2.5Molybdenum Stainless Steel Bar and Wire for Surgical Implants (UNS S31673)

F 562 Specification for Wrought Cobalt-35 Nickel-20 Chromium-10 Molybdenum Alloy for Surgical Implant Applications (UNS R30035)

F 563 Specification for Wrought Cobalt-20Nickel-20Chromium-3.5Molybdenum-3.5Tungsten-5Iron Alloy for Surgical Implant Applications (UNS R30563)

F 1314 Specification for Wrought Nitrogen Strengthened 22 Chromium-13Nickel-5Manganese-2.5Molybdenum Stainless Steel Alloy Bar and Wire for Surgical Implants (UNS S20910)

F 1537 Specification for Wrought Cobalt-28Chromium-6Molybdenum Alloy for Surgical Implants (UNS R31537, UNS R31538, and UNS R31539)

F 1586 Specification for Wrought Nitrogen Strengthened 21Chromium-10Nickel-3Manganese-2.5Molybdenum Stainless Steel Bar for Surgical Implants (UNS S31675)

3. Materials

3.1 Fixation pins and wires shall be fabricated from material conforming to one of the following ASTM Specifications: F 67, F 75, F 90, F 136, F 138, F 562, F 563, F 1314, F 1537, and F 1586.

4. Performance Requirements

4.1 Factors considered to be important, but for which values and test methods have not been established, are bending strength, fatigue strength, breaking strength (Knowles Type only), torsion strength, and ductility.

5. Dimensions and Characteristics

5.1 Fixation pins and wires shall be fabricated in accordance with the dimensions illustrated in Figs. 1-4.

5.2 Fixation pins and wires shall have surfaces prepared and marked in accordance with Practice F 86.

5.2.1 Optional marking on the fixation pins and wires shall identify the manufacturer or distributor.

6. Packaging and Labeling

6.1 Packaging shall be adequate to protect the fixation pins and wires during shipment.

6.2 Labeling for fixation pins and wires shall include:

6.2.1 Product name,

6.2.2 Size, on the immediate container,

6.2.2.1 Length,

¹ This specification is under the jurisdiction of ASTM Committee F04 on Medical and Surgical Materials and Devices and is the direct responsibility of Subcommittee F04.21 on Osteosynthesis.

Current edition approved Oct. 1, 2004. Published October 2004. Originally approved in 1973. Last previous edition approved in 2000 as F 366 – 82 (2000).

² For referenced ASTM standards, visit the ASTM website, www.astm.org, or contact ASTM Customer Service at service@astm.org. For *Annual Book of ASTM Standards* volume information, refer to the standard's Document Summary page on the ASTM website.

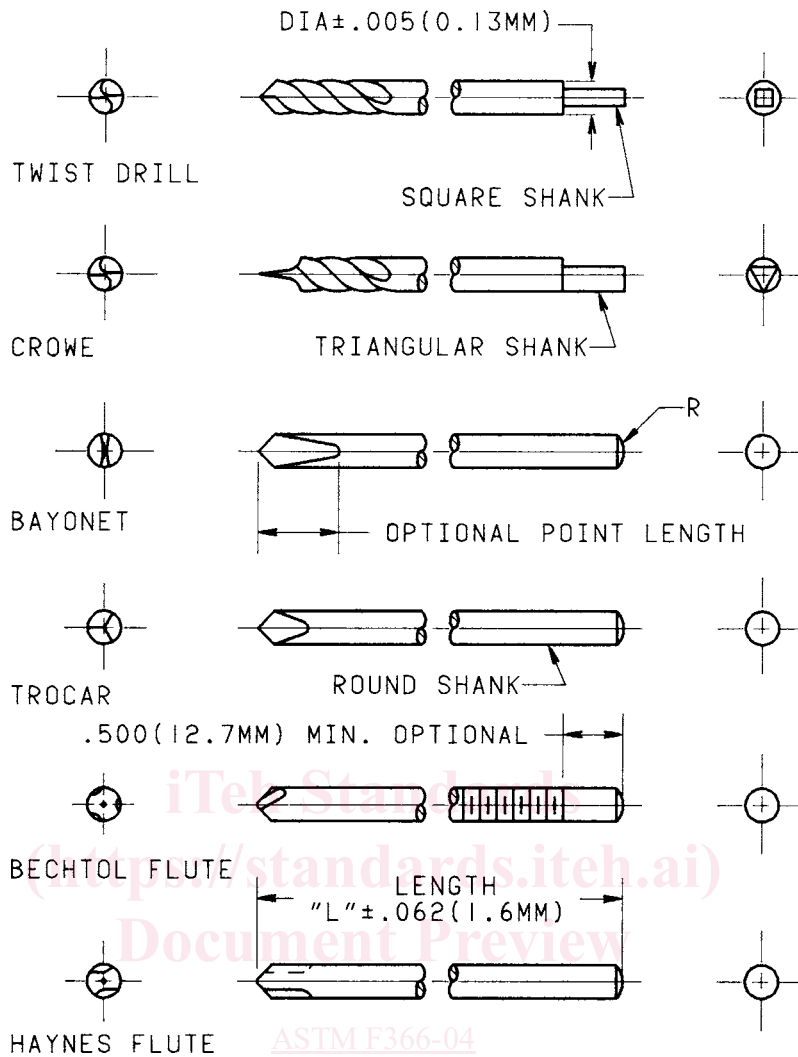

NOTE 1—Pins and wires may be smooth shank or threaded.

NOTE 2—Point angle and helix angle, where applicable, is as specified by manufacturer.

NOTE 3—On square or triangular shanks, flats are equal and corners are on the same circumference as the pin diameter. Shank diameters on pins larger than 1/8 in. (3.2 mm) may be reduced.

NOTE 4—Optional designs, both ends pointed or point with suture hole.

FIG. 1 Fixation Pins and Wires

6.2.2.2 Diameter (if round) or cross-sectional size (if square or hexagonal), that is, 1/4 in. (6.4 mm) square, and

6.2.3 ASTM material specification Designation number.

7. Keywords

7.1 fixation materials; flexible surgical wire; orthopaedic medical devices; wire-surgical implants