**Tool chucks (end mill holders) with clamp
screws for flatted cylindrical shank tools —**

**Part 1:
Dimensions of the driving system
of tool shanks**

iTeh STANDARD PREVIEW

*Mandrins porte-outils, à vis de blocage, pour outils à queue cylindrique
à méplat*

Partie 1: Dimensions du système d'entraînement des queues d'outils

ISO 5414-1:2002

[https://standards.iteh.ai/catalog/standards/sist/7e5f04ca-0775-4167-8163-
c538a8ba523a/iso-5414-1-2002](https://standards.iteh.ai/catalog/standards/sist/7e5f04ca-0775-4167-8163-c538a8ba523a/iso-5414-1-2002)



PDF disclaimer

This PDF file may contain embedded typefaces. In accordance with Adobe's licensing policy, this file may be printed or viewed but shall not be edited unless the typefaces which are embedded are licensed to and installed on the computer performing the editing. In downloading this file, parties accept therein the responsibility of not infringing Adobe's licensing policy. The ISO Central Secretariat accepts no liability in this area.

Adobe is a trademark of Adobe Systems Incorporated.

Details of the software products used to create this PDF file can be found in the General Info relative to the file; the PDF-creation parameters were optimized for printing. Every care has been taken to ensure that the file is suitable for use by ISO member bodies. In the unlikely event that a problem relating to it is found, please inform the Central Secretariat at the address given below.

iTeh STANDARD PREVIEW
(standards.iteh.ai)

ISO 5414-1:2002

<https://standards.iteh.ai/catalog/standards/sist/7e5f04ca-0775-4167-8163-c538a8ba523a/iso-5414-1-2002>

© ISO 2002

All rights reserved. Unless otherwise specified, no part of this publication may be reproduced or utilized in any form or by any means, electronic or mechanical, including photocopying and microfilm, without permission in writing from either ISO at the address below or ISO's member body in the country of the requester.

ISO copyright office
Case postale 56 • CH-1211 Geneva 20
Tel. + 41 22 749 01 11
Fax + 41 22 749 09 47
E-mail copyright@iso.ch
Web www.iso.ch

Printed in Switzerland

Foreword

ISO (the International Organization for Standardization) is a worldwide federation of national standards bodies (ISO member bodies). The work of preparing International Standards is normally carried out through ISO technical committees. Each member body interested in a subject for which a technical committee has been established has the right to be represented on that committee. International organizations, governmental and non-governmental, in liaison with ISO, also take part in the work. ISO collaborates closely with the International Electrotechnical Commission (IEC) on all matters of electrotechnical standardization.

International Standards are drafted in accordance with the rules given in the ISO/IEC Directives, Part 3.

The main task of technical committees is to prepare International Standards. Draft International Standards adopted by the technical committees are circulated to the member bodies for voting. Publication as an International Standard requires approval by at least 75 % of the member bodies casting a vote.

Attention is drawn to the possibility that some of the elements of this part of ISO 5414 may be the subject of patent rights. ISO shall not be held responsible for identifying any or all such patent rights.

ISO 5414-1 was prepared by Technical Committee ISO/TC 29, *Small tools*, Subcommittee SC 2, *Drills, reamers, milling cutters and milling machines accessories*.

This third edition cancels and replaces the second edition (ISO 5414-1:1985), which has been technically revised (in particular by the addition of shanks with diameters 14 mm and 18 mm, and of dimension l_4).

ISO 5414 consists of the following parts, under the general title *Tool chucks (end mill holders) with clamp screws for flatted cylindrical shank tools*:

- Part 1: *Dimensions of the driving system of tool shanks*
- Part 2: *Connecting dimensions of chucks and designation*

iTeh STANDARD PREVIEW
(standards.iteh.ai)

ISO 5414-1:2002

<https://standards.iteh.ai/catalog/standards/sist/7e5f04ca-0775-4167-8163-c538a8ba523a/iso-5414-1-2002>

Tool chucks (end mill holders) with clamp screws for flatted cylindrical shank tools —

Part 1: Dimensions of the driving system of tool shanks

1 Scope

This part of ISO 5414 lays down the dimensions of tool chucks (end mill holders) with clamp screws designed for driving flatted cylindrical shanks in accordance with ISO 3338-2 and specifies the clamp screws used. It also gives the maximum diameter of the chuck nose.

This part of ISO 5414 defines two types of drive:

- chucks with bores of $d_1 \leq 20$ mm intended for driving cylindrical shank tools with a single flat, these tools being provided with either a single or a double cutting part;
- chucks with bores of $d_1 \geq 25$ mm intended for driving cylindrical shank tools with a double flat, these tools being provided with a single cutting part only.

NOTE The connecting dimensions of the various types of chucks and the designation of tool chucks (end mill holders) with clamp screws are dealt with in ISO 5414-2. <https://standards.iteh.ai/catalog/standards/sist/7e5f04ca-0775-4167-8163-c538a8ba523a/iso-5414-1-2002>

2 Normative reference

The following normative document contains provisions which, through reference in this text, constitute provisions of this part of ISO 5414. For dated references, subsequent amendments to, or revisions of, any of these publications do not apply. However, parties to agreements based on this part of ISO 5414 are encouraged to investigate the possibility of applying the most recent edition of the normative document indicated below. For undated references, the latest edition of the normative document referred to applies. Members of ISO and IEC maintain registers of currently valid International Standards.

ISO 3338-2, *Cylindrical shanks for milling cutters — Part 2: Dimensional characteristics of flatted cylindrical shanks*

3 Dimensions

3.1 Chucks for tool shanks with single flat

See Figure 1 and Table 1.

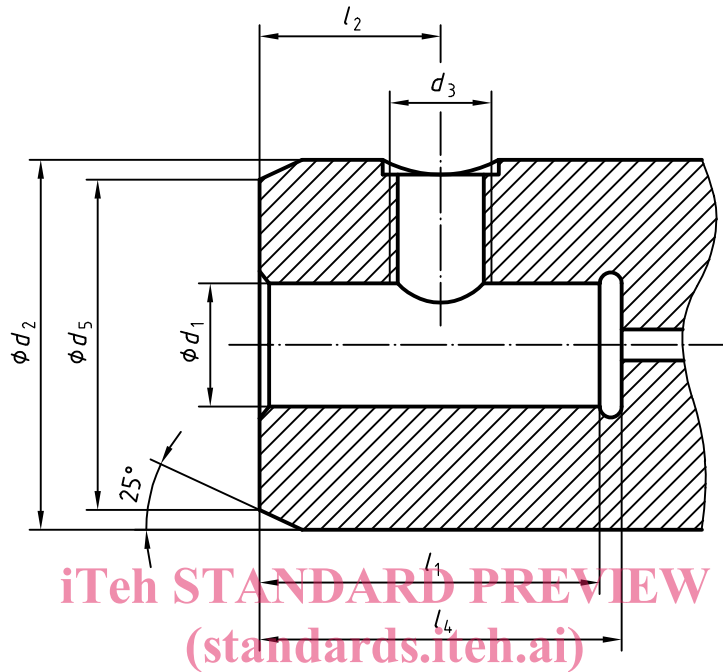

ISO 5414-1:2002
<https://standards.iteh.ai/catalog/standards/sist/7e5f04ca-0775-4167-8163-c538a8ba911e/iso-5414-1-2002>
Figure 1

Table 1

Dimensions in millimetres

d_1	l_1	l_2	l_4	d_2	d_3	d_5
H5	± 1	$-\frac{0}{1}$	min.	min.	6H	$-\frac{0}{1}$
6	35	18	37	25	M6	15
8	35	18	37	28	M8	20
10	39	20	41	35	M10	25
12	44	22,5	46	42	M12	30
14	44	22,5	46	44	M12	32
16	47	24	49	48	M14	36
18	47	24	49	50	M14	38
20	49	25	51	52	M16	40

3.2 Chucks for tool shanks with double flat

See Figure 2 and Table 2.

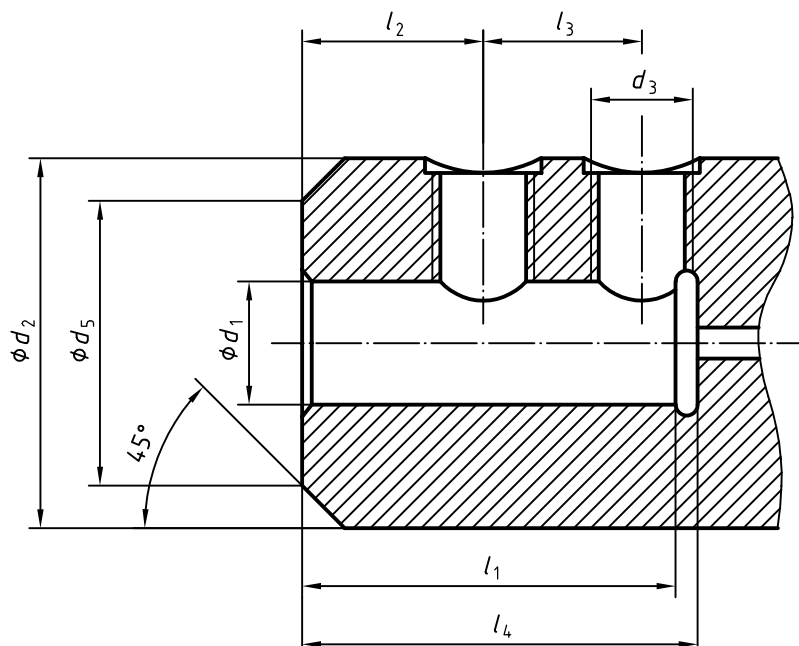

iTeh STANDARD PREVIEW
(standards.iteh.ai)

Figure 2

ISO 5414-1:2002

<https://standards.iteh.ai/catalog/standards/sist/7e5f04ca-0775-4167-8163-c538a8ba5231/iso-5414-1-2002>

Table 2

Dimensions in millimetres

d_1	l_1	l_2	l_3	l_4	d_2	d_3	d_5
H5	± 1	$-\frac{0}{1}$	$\pm 0,5$	min.		6H	$-\frac{0}{1}$
25	54	24	25	59	65	M18 × 2	45
32	58	24	28	63	72		$-\frac{0}{1}$
40	68	30	32	73	80	max.	60
50	78	35	35	83	90		70
63	88	40	40	93	130		M24 × 2

^a At the discretion of the manufacturer.

3.3 Clamp screw

See Figure 3 and Table 3.

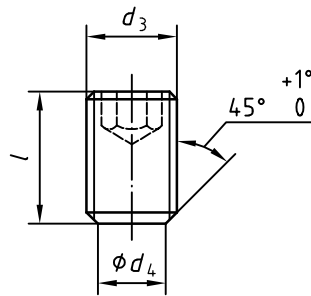

Figure 3

Table 3

Dimensions in millimetres

d_3 6h	d_4 $+0,1$ 0	l^a	Boring chucks, d_1
M6	4,2	10	6
M8	5,5	10	8
M10	7	12	10
M12	8	16	12
M14	10	16	16
M16	11	16	20
M18 × 2	12	20	25
M20 × 2	14	20	32
M20 × 2	14	25	40
M24 × 2	18	25	50
M24 × 2	18	33	63

^a The values given represent the screw nominal length for boring chucks $d_1 \leq 32$ mm. For larger chucks, l values are given for guidance and calculated from maximum values of d_5 . In the case of reduced d_5 bore, the screw length should be re-calculated making sure that the engagement length is appropriate.

Bibliography

- [1] ISO 5414-2, *Tool chucks (end mill holders) with clamp screws for flatted cylindrical shank tools — Part 2: Connecting dimensions of chucks and designation*

iTeh STANDARD PREVIEW
(standards.iteh.ai)

ISO 5414-1:2002

<https://standards.iteh.ai/catalog/standards/sist/7e5f04ca-0775-4167-8163-c538a8ba523a/iso-5414-1-2002>