**Anaesthetic and respiratory equipment —
Conical connectors —**

**Part 1:
Cones and sockets**

*Matériel d'anesthésie et de réanimation respiratoire — Raccords
coniques —
Partie 1: Raccords mâles et femelles*

[ISO 5356-1:2004](https://standards.iteh.ai/catalog/standards/sist/4caa62b1-5345-4088-a53e-8dea04dfeba3/iso-5356-1-2004)

<https://standards.iteh.ai/catalog/standards/sist/4caa62b1-5345-4088-a53e-8dea04dfeba3/iso-5356-1-2004>



PDF disclaimer

This PDF file may contain embedded typefaces. In accordance with Adobe's licensing policy, this file may be printed or viewed but shall not be edited unless the typefaces which are embedded are licensed to and installed on the computer performing the editing. In downloading this file, parties accept therein the responsibility of not infringing Adobe's licensing policy. The ISO Central Secretariat accepts no liability in this area.

Adobe is a trademark of Adobe Systems Incorporated.

Details of the software products used to create this PDF file can be found in the General Info relative to the file; the PDF-creation parameters were optimized for printing. Every care has been taken to ensure that the file is suitable for use by ISO member bodies. In the unlikely event that a problem relating to it is found, please inform the Central Secretariat at the address given below.

iTeh STANDARD PREVIEW
(standards.iteh.ai)

ISO 5356-1:2004

<https://standards.iteh.ai/catalog/standards/sist/4caa62b1-5345-4088-a53e-8dea04dfeba3/iso-5356-1-2004>

© ISO 2004

All rights reserved. Unless otherwise specified, no part of this publication may be reproduced or utilized in any form or by any means, electronic or mechanical, including photocopying and microfilm, without permission in writing from either ISO at the address below or ISO's member body in the country of the requester.

ISO copyright office
Case postale 56 • CH-1211 Geneva 20
Tel. + 41 22 749 01 11
Fax + 41 22 749 09 47
E-mail copyright@iso.org
Web www.iso.org

Published in Switzerland

Contents

Page

Foreword	iv
Introduction	v
1 Scope.....	1
2 Normative references	1
3 Terms and definitions.....	2
4 Conical connectors made of metal	2
4.1 General requirements	2
4.2 Additional requirements for male conical connectors of 22 mm size	2
4.3 Additional requirements for conical connectors of 8,5 mm size	4
5 Conical connectors made of materials other than metal.....	4
5.1 General requirements	4
5.2 Additional requirements for conical connectors of 22 mm size	4
5.3 Additional requirements for conical connectors of 8,5 mm size	4
6 22 mm latching connectors.....	4
Annex A (normative) Plug and ring test gauges for conical connectors made of materials other than metal	5
Annex B (normative) Test for security of engagement of 22 mm latching connector to male conical connector	7
Annex C (normative) Test for leakage from 22 mm latching connectors.....	8
Annex D (normative) Drop procedure for 22 mm latching connectors.....	9
Annex E (informative) Plug and ring test gauges for conical connectors made of metal	10
Annex F (informative) Suggested apparatus and methods for testing the security of engagement of 22 mm latching connectors	12
Bibliography	16

Foreword

ISO (the International Organization for Standardization) is a worldwide federation of national standards bodies (ISO member bodies). The work of preparing International Standards is normally carried out through ISO technical committees. Each member body interested in a subject for which a technical committee has been established has the right to be represented on that committee. International organizations, governmental and non-governmental, in liaison with ISO, also take part in the work. ISO collaborates closely with the International Electrotechnical Commission (IEC) on all matters of electrotechnical standardization.

International Standards are drafted in accordance with the rules given in the ISO/IEC Directives, Part 2.

The main task of technical committees is to prepare International Standards. Draft International Standards adopted by the technical committees are circulated to the member bodies for voting. Publication as an International Standard requires approval by at least 75 % of the member bodies casting a vote.

Attention is drawn to the possibility that some of the elements of this document may be the subject of patent rights. ISO shall not be held responsible for identifying any or all such patent rights.

ISO 5356-1 was prepared by Technical Committee ISO/TC 121, *Anaesthetic and respiratory equipment*, Subcommittee SC 1, *Breathing attachments and anaesthetic machines*.

This third edition cancels and replaces the second edition (ISO 5356-1:1996), which has been technically revised. The major differences are the inclusion of 8.5 mm size connectors and some minor corrections to the figures and tables.

ISO 5356 consists of the following parts, under the general title *Anaesthetic and respiratory equipment — Conical connectors*:

- *Part 1: Cones and sockets*
- *Part 2: Screw-threaded weight-bearing connectors*

Introduction

In clinical practice, several breathing attachments used in anaesthetic and respiratory equipment may have to be joined together to provide a suitable breathing system. Items of medical equipment, such as a humidifier or a spirometer, are often incorporated into the breathing system which may also be connected to an anaesthetic-gas scavenging system. Connections for these purposes are usually cone and socket joints, and a lack of standardization of these connections has given rise to problems of interchangeability when connecting equipment made by different manufacturers. This part of ISO 5356 specifies the requirements and dimensions for conical connectors used in anaesthetic and respiratory equipment.

An important consideration is that conical connections need to be secure but nevertheless disconnectable by the operator. The use of connectors meeting the requirements of this part of ISO 5356 will not necessarily prevent them being disconnected accidentally. To minimize the risk of 22 mm connectors being accidentally disconnected, latching connectors can be used.

Annex A includes a figure and a table detailing plug and ring test gauges that are used to check conical connectors made of materials other than metal. Annexes B, C and D provide test methods for latching connectors, Annex E includes a figure and table detailing plug and ring test gauges that may be used to check metal conical connectors, and Annex F contains recommendations for testing security of latching connectors.

Figure 1, detailing the dimensions and tolerances of metal conical connectors, has been prepared in accordance with ISO 3040.

ITeC STANDARD PREVIEW
(standards.iteh.ai)

<https://standards.iteh.ai/catalog/standards/sist/4caa62b1-5345-4088-a53e-8dea04dfeba3/iso-5356-1-2004>

iTeh STANDARD PREVIEW
(standards.iteh.ai)

ISO 5356-1:2004

<https://standards.iteh.ai/catalog/standards/sist/4caa62b1-5345-4088-a53e-8dea04dfeba3/iso-5356-1-2004>

Anaesthetic and respiratory equipment — Conical connectors —

Part 1: Cones and sockets

1 Scope

This part of ISO 5356 specifies dimensional and gauging requirements for cones and sockets intended for connecting anaesthetic and respiratory equipment, e.g. in breathing systems, anaesthetic-gas scavenging systems and vaporizers.

This part of ISO 5356 gives requirements for the following conical connectors:

- 8,5 mm size intended for use in paediatric breathing systems;
- 15 mm and 22 mm sizes intended for general use in breathing systems;
- 22 mm latching connectors (including performance requirements);
- 23 mm size intended for use with vaporizers, but not for use in breathing systems;
- 30 mm size intended for the connection of a breathing system to an anaesthetic gas scavenging system.

This part of ISO 5356 does not specify the medical devices and accessories on which these connections are to be provided.

Requirements for the application of conical connectors are not included in this part of ISO 5356, but are or will be given in the relevant International Standards for specific medical devices and accessories.

NOTE Requirements for screw-threaded weight-bearing conical connectors are specified in ISO 5356-2.

2 Normative references

The following referenced documents are indispensable for the application of this document. For dated references, only the edition cited applies. For undated references, the latest edition of the referenced document (including any amendments) applies.

ISO 4135, *Anaesthetic and respiratory equipment — Vocabulary*

ISO 5367, *Breathing tubes intended for use with anaesthetic apparatus and ventilators*

IEC 60601-1:1988, *Medical electrical equipment — Part 1: General requirements for safety*, including Amendment 1:1991 and Amendment 2:1995

3 Terms and definitions

For the purposes of this document, the terms and definitions given in ISO 4135 and the following apply.

3.1
22 mm latching connector
 female connector for engagement with a male conical connector of 22 mm size complying with this part of ISO 5356, and which has a feature to reduce the possibility of accidental disconnection

4 Conical connectors made of metal

4.1 General requirements

The dimensions of conical connectors made of metal, including those made of composite materials in which the mating surfaces are metal, shall be as shown in Figures 1 and 2 and Table 1.

NOTE See Annex E for dimensions of plug and ring gauges for the connectors.

4.2 Additional requirements for male conical connectors of 22 mm size

4.2.1 Male conical connectors of 22 mm size, with the exception of those intended for connection to a face mask, shall incorporate the recess as shown in Figure 2 a).

4.2.2 Male conical connectors of 22 mm size to which it is intended to attach a face mask shall incorporate a shoulder or equivalent construction as shown in Figure 2 b).

4.2.3 If a circumferential groove or grooves are incorporated in the surface of a male conical connector of 22 mm size, the total width of the groove or grooves at the surface shall not exceed 8 mm.

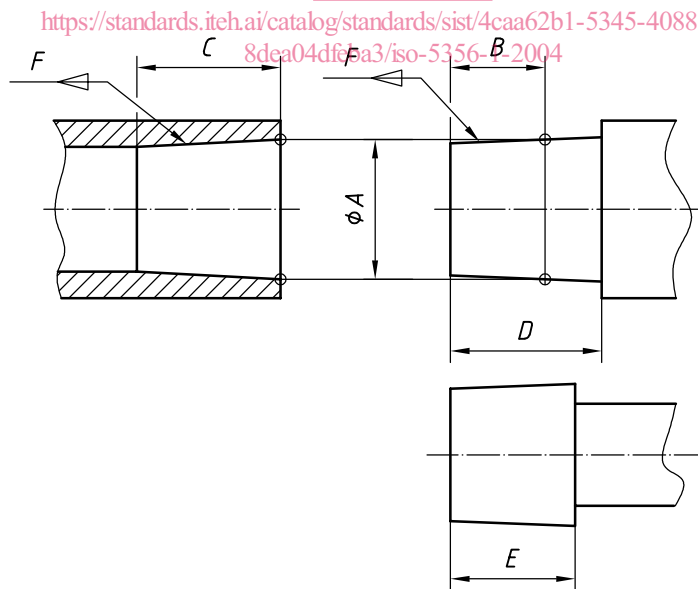

The radius on the entrance to the female connector and on the leading edge of the male cone should be not less than 0,5 mm and not more than 0,8 mm.

Figure 1 — Conical connectors made of metal

Table 1 — Conical connectors made of metal — Dimensions (see Figure 1)

Connector size mm	<i>A</i> mm	<i>B</i> mm	Taper length min. <i>C</i> mm	Clearance to shoulder (if present) <i>D</i> mm	Length to taper min. <i>E</i> mm	Taper ratio <i>F</i>
8,5	8,45 ± 0,04	6	6,4	8,9 min.	8	1:19
15	15,47 ± 0,04	10	16	16 min.	14,5	1:40
22	22,37 ± 0,04	15	21	See Figure 2	See Figure 2	1:40
23	23,175 ± 0,02	13	18	18 min.	15	1:36
30	30,9 ± 0,05	14	18	18 min.	14	1:20

Dimensions in millimetres

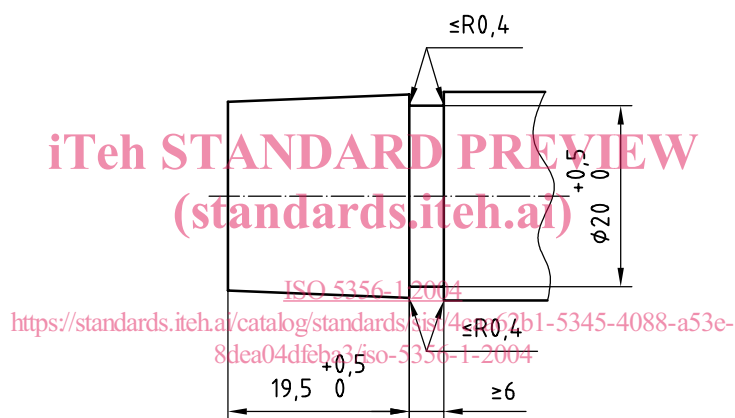

a) Connector intended for breathing attachment (with recess)

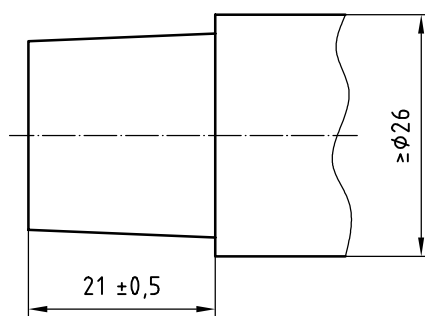

b) Connector intended for face mask (with shoulder)

Circumferential grooves may be incorporated on the surface of the male cone, if required (see 4.2.3).

Figure 2 — Conical connectors of 22 mm size made of metal — Supplementary dimensions

4.3 Additional requirements for conical connectors of 8,5 mm size

The male conical connector shall have a minimum inside diameter of 6 mm extending inward for at least 6 mm from the end of the connector.

5 Conical connectors made of materials other than metal

5.1 General requirements

Conical connectors made of materials other than metal shall meet the following requirements when they are type-tested with gauges having dimensions as shown in Figure A.1 and Table A.1.

- a) Conical connectors made of materials other than metal shall meet the dimensional requirements in Figure 1 and Table 1, with the exception that dimensions A and B and ratio F may vary from those shown.
- b) When the connector is engaged in the appropriate plug or ring test gauge shown in Figure A.1 and Table A.1, by applying an axial force of $(35 \pm 3,5)$ N for 8,5 mm and 15 mm connectors and (50 ± 5) N for 22 mm and 30 mm connectors and, while maintaining the same force, rotating the connector up to 20° , its leading edge shall lie between the minimum and maximum diameter steps of the gauge. The connectors and gauges shall be maintained at a temperature of (20 ± 3) °C during the test.

NOTE Because connectors made from plastics materials, for example polyamide, polyacetal, polycarbonate, polysulfone, etc., can vary greatly in their physical characteristics, it is not considered practicable to specify their dimensions; for this reason, gauging requirements have been included. It is also considered impracticable to generalize on matters such as cold flow and thermal instability, as well as possible changes in physical characteristics, contact with solvents, etc.

It is the responsibility of the manufacturer to ensure that adequate tests have been carried out to prove as far as possible that the particular materials chosen for the connectors are suitable.

<https://standards.iteh.ai/catalog/standards/sist/4caa62b1-5345-4088-a53e-8dea01dfbba3/iso-5356-1-2004>

5.2 Additional requirements for conical connectors of 22 mm size

The requirements given in 4.2 apply.

5.3 Additional requirements for conical connectors of 8,5 mm size

The requirements given in 4.3 apply.

6 22 mm latching connectors

6.1 22 mm latching connectors shall engage with the 22 mm male connector with a recess as specified in Figure 2 a).

6.2 When tested in accordance with Annex B, the engaged connection shall not become disconnected.

6.3 When tested in accordance with Annex C, the leakage rate from the engaged connectors shall not exceed 5 ml/min (corrected to 20 °C and 101,3 kPa).

6.4 After being subjected to the procedure described in Annex D, the 22 mm latching connector shall still meet the requirements in 6.1, 6.2 and 6.3.

6.5 22 mm latching connectors intended for re-use shall meet the requirements in 6.1, 6.2, 6.3 and 6.4 after being subjected to the cleaning, disinfection or sterilization procedures specified in IEC 60601-1:1998, 44.7.

Annex A (normative)

Plug and ring test gauges for conical connectors made of materials other than metal

Figure A.1 and Table A.1 give details of plug and ring gauges for use in checking conical connectors made of materials other than metals.

Dimensions in millimetres
Surface roughness values in micrometres

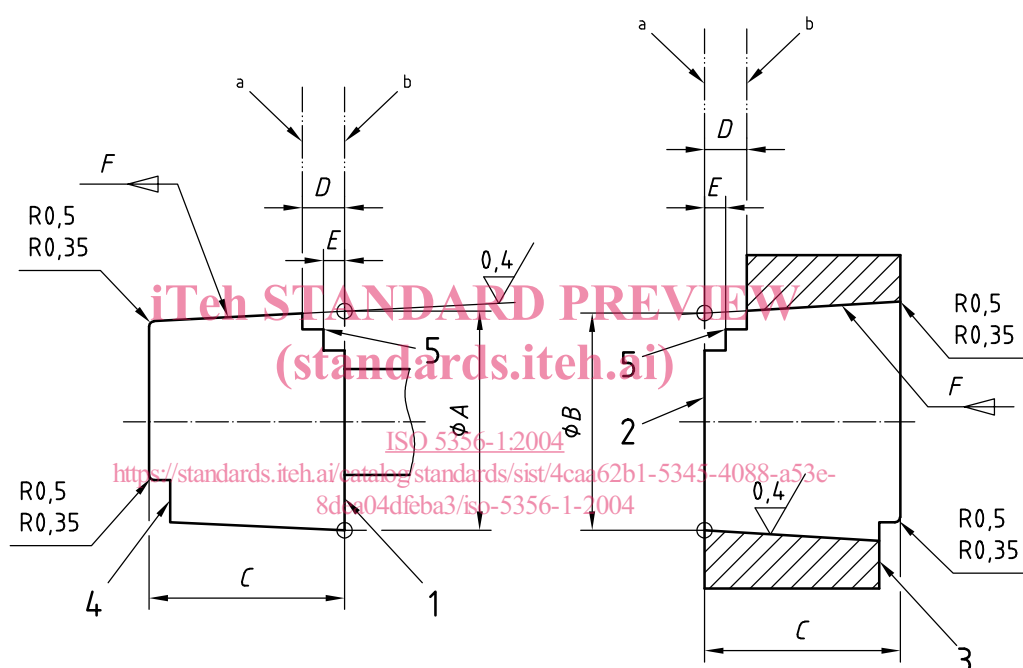

Key

- 1 face A
- 2 face B
- 3 step to check mating gauges ground flush to face A
- 4 step to check mating gauges ground flush to face B
- 5 basic steps
- a Position max.
- b Position min.

NOTE Basic and mating gauge steps are optional.

Figure A.1 — Plug and ring test gauges for conical connectors made of materials other than metal