

---

---

**Fine ceramics (advanced ceramics,  
advanced technical ceramics) —  
Determination of particle size distribution  
of ceramic powders by laser diffraction  
method**

*Céramiques techniques — Détermination de la répartition  
granulométrique des poudres céramiques au moyen d'une méthode par  
diffraction laser*  
(standards.iteh.ai)

[ISO 24235:2007](https://standards.iteh.ai/catalog/standards/sist/94428213-a392-4ae5-bc78-26c855e6bdf1/iso-24235-2007)

[https://standards.iteh.ai/catalog/standards/sist/94428213-a392-4ae5-bc78-  
26c855e6bdf1/iso-24235-2007](https://standards.iteh.ai/catalog/standards/sist/94428213-a392-4ae5-bc78-26c855e6bdf1/iso-24235-2007)



**PDF disclaimer**

This PDF file may contain embedded typefaces. In accordance with Adobe's licensing policy, this file may be printed or viewed but shall not be edited unless the typefaces which are embedded are licensed to and installed on the computer performing the editing. In downloading this file, parties accept therein the responsibility of not infringing Adobe's licensing policy. The ISO Central Secretariat accepts no liability in this area.

Adobe is a trademark of Adobe Systems Incorporated.

Details of the software products used to create this PDF file can be found in the General Info relative to the file; the PDF-creation parameters were optimized for printing. Every care has been taken to ensure that the file is suitable for use by ISO member bodies. In the unlikely event that a problem relating to it is found, please inform the Central Secretariat at the address given below.

**iTeh STANDARD PREVIEW**  
**(standards.iteh.ai)**

[ISO 24235:2007](https://standards.iteh.ai/catalog/standards/sist/94428213-a392-4ae5-bc78-26c855e6bdf1/iso-24235-2007)

<https://standards.iteh.ai/catalog/standards/sist/94428213-a392-4ae5-bc78-26c855e6bdf1/iso-24235-2007>

© ISO 2007

All rights reserved. Unless otherwise specified, no part of this publication may be reproduced or utilized in any form or by any means, electronic or mechanical, including photocopying and microfilm, without permission in writing from either ISO at the address below or ISO's member body in the country of the requester.

ISO copyright office  
Case postale 56 • CH-1211 Geneva 20  
Tel. + 41 22 749 01 11  
Fax + 41 22 749 09 47  
E-mail [copyright@iso.org](mailto:copyright@iso.org)  
Web [www.iso.org](http://www.iso.org)

Published in Switzerland

**Contents**

Page

Foreword.....	iv
<b>1 Scope .....</b>	<b>1</b>
<b>2 Normative references .....</b>	<b>1</b>
<b>3 Terms and definitions.....</b>	<b>1</b>
<b>4 Principle of measurement.....</b>	<b>2</b>
<b>5 Equipment .....</b>	<b>2</b>
<b>6 Dispersion medium.....</b>	<b>4</b>
<b>7 Sample preparation .....</b>	<b>4</b>
<b>8 Measuring procedure .....</b>	<b>4</b>
<b>9 Report of result .....</b>	<b>5</b>

**iTeh STANDARD PREVIEW**  
**(standards.iteh.ai)**

[ISO 24235:2007](https://standards.iteh.ai/catalog/standards/sist/94428213-a392-4ae5-bc78-26c855e6bdf1/iso-24235-2007)

<https://standards.iteh.ai/catalog/standards/sist/94428213-a392-4ae5-bc78-26c855e6bdf1/iso-24235-2007>

## Foreword

ISO (the International Organization for Standardization) is a worldwide federation of national standards bodies (ISO member bodies). The work of preparing International Standards is normally carried out through ISO technical committees. Each member body interested in a subject for which a technical committee has been established has the right to be represented on that committee. International organizations, governmental and non-governmental, in liaison with ISO, also take part in the work. ISO collaborates closely with the International Electrotechnical Commission (IEC) on all matters of electrotechnical standardization.

International Standards are drafted in accordance with the rules given in the ISO/IEC Directives, Part 2.

The main task of technical committees is to prepare International Standards. Draft International Standards adopted by the technical committees are circulated to the member bodies for voting. Publication as an International Standard requires approval by at least 75 % of the member bodies casting a vote.

Attention is drawn to the possibility that some of the elements of this document may be the subject of patent rights. ISO shall not be held responsible for identifying any or all such patent rights.

ISO 24235 was prepared by Technical Committee ISO/TC 206, *Fine ceramics*.

## iTeh STANDARD PREVIEW (standards.iteh.ai)

ISO 24235:2007

<https://standards.iteh.ai/catalog/standards/sist/94428213-a392-4ae5-bc78-26c855e6bdf1/iso-24235-2007>

# Fine ceramics (advanced ceramics, advanced technical ceramics) — Determination of particle size distribution of ceramic powders by laser diffraction method

## 1 Scope

This International Standard specifies a laser diffraction method for measuring particle size distributions, by means of the detection of angular distributions of the intensity of light scattered by fine-ceramic raw powders dispersed in a liquid phase irradiated by a laser beam. A typical size range is 0,1  $\mu\text{m}$  to 50  $\mu\text{m}$ .

## 2 Normative references

The following referenced documents are indispensable for the application of this document. For dated references, only the edition cited applies. For undated references, the latest edition of the referenced document (including any amendments) applies.

ISO 3082:2000, *Iron ores — Sampling and sample preparation procedures*

ISO 13320-1:1999, *Particle size analysis — Laser diffraction methods — Part 1: General principles*

ISO 14703:2000, *Fine ceramics (advanced ceramics, advanced technical ceramics) — Sample preparation for the determination of particle size distribution of ceramic powders*

ISO 14887:2000, *Sample preparation — Dispersing procedures for powders in liquids.*

## 3 Terms and definitions

For the purposes of this document, the terms and definitions given in ISO 13320-1 apply, together with the following.

### 3.1

#### **angular distribution of intensity of light scattered**

intensity of light scattered as a function of scattering angle

### 3.2

#### **scattering angle**

angle between the directions of the transmitted laser beam and the scattered light detected

### 3.3

#### **relative refractive index**

ratio of the absolute refractive index of the sample to the real part of the dispersion medium

## 4 Principle of measurement

A particle illuminated by a collimated light beam of a known wavelength from a laser presents a scattering signature that is a function of the size, shape and relative refractive index of the particle. When particles dispersed in a liquid are irradiated by a laser beam, the scattering signature is supposed to be the summation of the signatures of each particle. In the basic optical system shown in Figure 1, the light scattered by the particles in the laser beam is collected by a Fourier lens on the detector placed on the focal plane of the lens, to detect the angular distribution of the scattered intensity. The size distribution of the particles is mathematically reduced from the measured angular distribution of the scattered intensity, so that it can be best-fitted with that predicted, based on the Mie scattering theory, Fraunhofer diffraction theory or the like.

NOTE 1 A detailed description of the principle of laser diffraction method is found in ISO 13320-1:1999, Annex D.

NOTE 2 For particles of smaller diameters, light scattering at angles in the side and back lobes may also be utilized for the determination of the size distribution of particles.

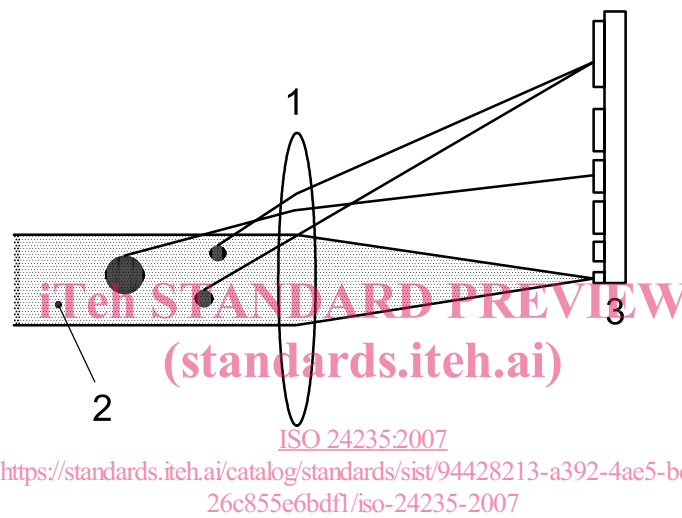

### Key

- 1 fourier lens
- 2 laser beam
- 3 scattered-light detector

**Figure 1 — Schematic drawing of an optical system used for size-distribution measurements of particles by the laser diffraction method**

## 5 Equipment

### 5.1 Equipment for determination of particle size distribution

The fundamental constitution of measuring equipment shall be that shown in Figure 2.

**5.1.1** The suspension in the dispersion tank, equipped with stirring blades, shall be circulated by a pump. A laser is used as the radiation light source.

NOTE A He-Ne gas laser or semiconductor laser is used.

**5.1.2** The laser beam is expanded into a parallel beam by the beam expander/collimator unit to illuminate a group of particles in the flow cell.

NOTE A stirrer-type batch cell is also used.

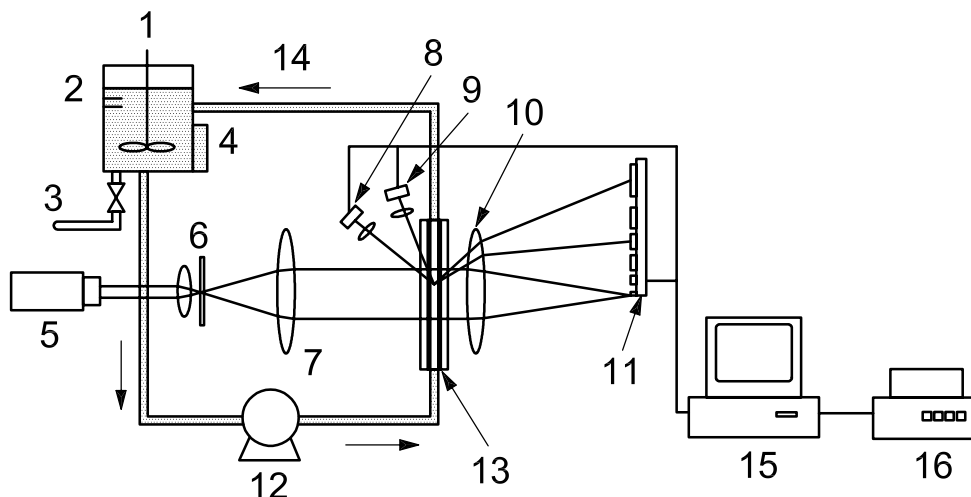

### Key

- 1 stirring blade
- 2 dispersion tank
- 3 exhaust liquid
- 4 ultrasonic vibrator
- 5 laser
- 6 pin hole
- 7 beam-enlarging apparatus
- 8 back-scattering light detector
- 9 side-scattered light detector
- 10 Fourier lens
- 11 forward-scattered light detector
- 12 circulation pump
- 13 flow cell
- 14 flow of suspension
- 15 operational processor
- 16 printer

**iTeh STANDARD PREVIEW**  
(standards.iteh.ai)

[ISO 24235:2007](https://standards.iteh.ai/catalog/standards/sist/94428213-a392-4ae5-bc78-26c855e6bdf1/iso-24235-2007)

<https://standards.iteh.ai/catalog/standards/sist/94428213-a392-4ae5-bc78-26c855e6bdf1/iso-24235-2007>

**Figure 2 — Typical example of particle-size-distribution measuring equipment for laser diffraction method**

**5.1.3** The scattered light from the illuminated particles is collected by a Fourier lens on the detector consisting of photoelectric elements positioned at the focal plane of the lens. Some models have additional detectors in the side and back in order to detect the light scattered at larger scattering angles.

**5.1.4** The electric signal from each element of the detector is A/D-converted and then sent to the operational processor. The size distributions of the particles are derived from the signals from all detectors.

**5.1.5** The equipment for the determination of particle size distribution used for making measurements in accordance with this International Standard is subject to a regular verification procedure.

**5.1.6** The operators of the equipment shall have received adequate training to ensure they are competent for conducting the measurements to be reported.

## 5.2 Equipment for preparation of sample

An ultrasonic dispersing device shall be used. A built-in ultrasonic disperser may be used.

## 6 Dispersion medium

The type of dispersion medium and the method for evaluating the scattering conditions shall be as specified in ISO 14703 and ISO 14887.

## 7 Sample preparation

### 7.1 Sampling

Sampling shall be carried out in accordance with ISO 3082.

### 7.2 Preparation of sample suspensions

The preparation of sample suspensions shall be carried out in accordance with ISO 14703.

## 8 Measuring procedure

The measuring procedure shall be as follows.

- 8.1 Turn on the power supply to the measuring equipment 30 min or more before the start of measurement.
- 8.2 Select an appropriate dispersion medium (Clause 6) and conduct sampling in accordance with 7.1, and prepare a suspension of the sample.
- 8.3 Input the refractive index (indices) of the particles and dispersion medium if the equipment accepts their input.

NOTE Care must be taken to specify whether the requested refractive index is absolute or relative.

Refractive indices of some isotropic materials are listed in Table D.2 in ISO 13320-1:1999, Annex D. Other values can be used when agreed between the supplier and the user of data, provided that they are reported. It should be noted that the refractive indices of the materials and dispersion medium are of crucial importance, especially when the particles are in the sub-micron range.

- 8.4 Establish the number of times that scattering-intensity data is taken, and the measuring conditions.
- 8.5 After supplying the dispersion tank with the dispersion medium, fill the circulation line with the dispersion medium.
- 8.6 Confirm that the laser beam has been aligned with the centre of the detector.
- 8.7 Allow the dispersion medium to circulate.
- 8.8 Carry out the background measurements.
- 8.9 Drip the suspension prepared in 8.2 into the dispersion tank, by using a squirt or the like, until a concentration appropriate for the high signal/noise ratio detection of the scattered light intensity is reached.

NOTE The value of obscuration or transmittance of the laser beam is a good index to judge whether multiple scattering is incurred.

- 8.10 Carry out the particle-size-distribution measurements, and record the results.



## 9 Report of result

### 9.1 Conditions of sample preparation and measurement

#### 9.1.1 Conditions of sample preparation

The conditions of sample preparation and the like shall be indicated in accordance with ISO 14703.

#### 9.1.2 Measuring conditions

The measuring conditions shall be indicated in accordance with the entry format of Table 1.

### 9.2 Measured results

The measured results shall be stated as follows:

**9.2.1** Size distributions in cumulative volume percentages shall be presented by means of graphs and tables.

**9.2.2** Diameters at 10 %, 50 % and 90 % cumulative percentages in distribution shall be indicated in accordance with the entry format of Table 1.

**9.2.3** Particle size distributions, other than cumulative volume percentages, shall be made with the parameter on the abscissa clearly mentioned.

**iTeh STANDARD PREVIEW**  
**(standards.iteh.ai)**

[ISO 24235:2007](https://standards.iteh.ai/catalog/standards/sist/94428213-a392-4ae5-bc78-26c855e6bdf1/iso-24235-2007)

<https://standards.iteh.ai/catalog/standards/sist/94428213-a392-4ae5-bc78-26c855e6bdf1/iso-24235-2007>