



Designation: F 504 – 04

Standard Test Method for Measuring the Quasi-Static Release Moments of Alpine Ski Bindings¹

This standard is issued under the fixed designation F 504; the number immediately following the designation indicates the year of original adoption or, in the case of revision, the year of last revision. A number in parentheses indicates the year of last reapproval. A superscript epsilon (ϵ) indicates an editorial change since the last revision or reapproval.

1. Scope

1.1 This test method covers a procedure for the measurement of release moments of ski bindings under conditions where inertia loadings of the ski binding system are not significant.

1.2 *This standard does not purport to address all of the safety concerns, if any, associated with its use. It is the responsibility of the user of this standard to establish appropriate safety and health practices and determine the applicability of regulatory limitations prior to use.*

2. Referenced Documents

2.1 *ASTM Standards:*²

F 498 Test Method for Center Spring Constant and Spring Constant Balance of Alpine Skis

F 779 Test Method for Torsion Characteristics of Alpine Skis

F 944 Specification for Properties of Adult Alpine Ski Boots³

2.2 *ISO Standard:*⁴

ISO 9838 Alpine Ski Bindings—Test Soles for Ski Binding Tests

ISO 9462 Alpine Ski Bindings—Safety Requirements and Test Methods

ISO 9465 Alpine Ski Bindings—Lateral Release under Impact Loading—Test Method

3. Terminology

3.1 The following terminology is introduced with reference to the sketch of the boot-ski system shown in Fig. 1.

3.1.1 Six points of load application to the standard test ski are required. With the adult boot sole (300 mm in length) the

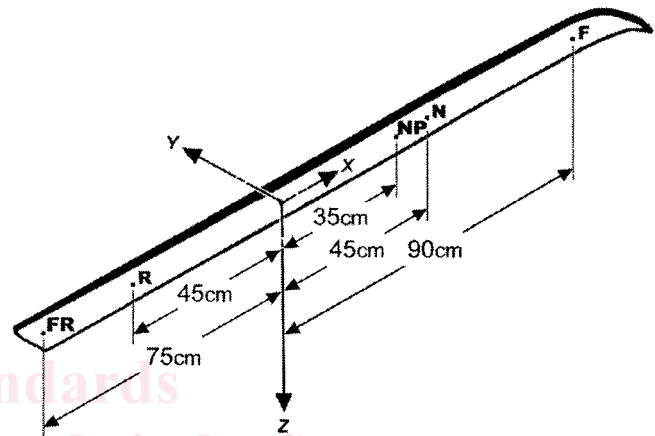

FIG. 1 Load Application

most forward point, located at a position 90 ± 0.5 cm from the centerline of the test shaft, shall be called the “forward point” and shall be designated as *F*. The second point, 45 ± 0.5 cm in front of the centerline of the test shaft, shall be designated the “near point,” *N*. The third point, located 45 ± 0.5 cm behind the centerline of the test shaft, shall be designated “rear point,” *R*. The fourth point, located 35 ± 0.5 cm in front of the center line of the test shaft, shall be designated the “near preload point,” *NP*. The fifth point, located 75 ± 0.5 cm behind the centerline of the test shaft shall be designated the “far rear point,” *FRP*. The sixth point, the “alternate near preload point,” *ANP*, is located 7.5 ± 0.25 cm, in the minus *y*-direction from the point *NP*. For sole lengths longer than 300 mm the *F* and *FR* points are not changed from the location used for the 300 mm boot sole. For sole lengths shorter than 300 mm the *N*, *R*, *ANP* and *NP* points are not changed from the location used for the 300 mm sole. For bindings which are to be used exclusively with skis shorter than the test ski, *F* and *FR* tests shall be performed at the *N* and *R* points. If the ski is too short for the specified *N* and *R* points, *N* and *R* shall be moved closer to the *z*-axis by 10 cm each, and all tests performed using the new *N* and *R* points. The forces that are applied to the standard ski at these six designated points may now be described by simple vector notation. A laboratory-fixed axis designation shall be used with the numeral *z* denoting the vertical axis normal to the top face

¹ This test method is under the jurisdiction of ASTM Committee F27 on Snow Skiing and is the direct responsibility of Subcommittee F27.10 on Binding Test Procedures.

Current edition approved Sept. 1, 2004. Published October 2004. Originally approved in 1977. Last previous edition approved in 2000 as F 504 – 00.

² For referenced ASTM standards, visit the ASTM website, www.astm.org, or contact ASTM Customer Service at service@astm.org. For *Annual Book of ASTM Standards* volume information, refer to the standard’s Document Summary page on the ASTM website.

³ Withdrawn.

⁴ Available from American National Standards Institute (ANSI), 25 W. 43rd St., 4th Floor, New York, NY 10036.

of the ski (in the region of the test shaft) and positive in the direction outward from the ski; the numeral x denoting the longitudinal axis, positive in the forward direction of the ski; and the numeral y denoting the lateral axis, the positive direction of which is determined by the right-hand rule. The z -axis is coincident with the centerline of the test shaft. The origin of the XYZ coordinate system is a point 230 mm along the axis of the test shaft from the bearing surface of the test sole for 300 mm test soles. The location is changed proportionally for soles other than 300 mm. The direction of any force applied to the ski is defined by its unit vector. The magnitude of a preload force applied to the ski is defined by the M_z or M_y moment created by the force.

4. Summary of Test Method

4.1 The ski binding is mounted on a standard ski and a standard boot sole is inserted into the binding. A relatively stiff test shaft instrumented for moments is affixed to the sole and attached rigidly to the test frame. The apparatus is shown in Fig. 2.

4.2 Loads sufficient to produce binding release are applied to the binding by forcing the ski to displace relative to the frame until release occurs. The components of the moments transmitted through the binding to the test shaft are recorded. These records are interpreted to provide the static release moments of the binding.

5. Significance and Use

5.1 This test method involves simulation in the laboratory of potential injury-producing loads that can occur in skiing, without implying the frequency or the magnitude of the danger. This test method does not include the simulation of all or part of a skier, and care must be taken not to confuse the values of moments measured by the test shaft with the loads subjected to the tibia of a skier under the same conditions.

6. Apparatus

6.1 Ski:

6.1.1 *Ski*—Three test skis are defined in Table 1 of ISO 9462. The mounting platform shall be as specified in the relevant ASTM standard. The boot’s ski location marker as

shown on Specification F 944 or ISO 9838 shall be aligned with the boot centerline marker on the ski. If there are no markers on the boot or ski the center of the boot sole shall be located 15 ± 0.5 cm behind the center of the ski’s projected length unless the relevant ASTM standard applies.

6.2 *Boot*—Four test soles are defined in Table 2 of ISO 9462. The standard adult sole shall be 30 ± 0.5 cm in length and shall be adjustable, over a range of ± 4 cm. It shall be constructed to meet the requirements of ISO 9838. Details concerning boot characteristics shall conform to the relevant ASTM standard. However, it shall be permissible to modify the boot if the binding manufacturer specifies that modification is necessary for proper function of the binding.

6.3 *Stiffener*—When a ski stiffener is called for (see Annex A1 and Annex A2), a channel of dimensions 75 to 80 mm wide by 35 to 40 mm high by 4 to 5 mm thick shall be used to stiffen the ski between the near and rear points. The channel shall be made of 6061 T6 aluminum, or equivalent. The bar shall be attached to the ski by bolts, screws, or clamps at N and R points and at a point half way between N and R points. The stiffener described in Fig. A1.1 meets this requirement.

6.4 Test Frame:

6.4.1 The test frame consists of all mechanical components that connect the boot to a stationary reference, including the boot sole attachment, the test shaft, and the supporting structure for the test shaft. The test frame shall include a boot sole attachment constructed in accordance with ISO 9838 for the standard sole.

6.4.2 The angle between the bottom of the boot sole and the test shaft shall be $90 \pm 1^\circ$ in the z - x and z - y planes; the positions of centerline of the test shaft relative to the boot shall be at a longitudinal location 20 ± 1 cm from the front of the boot sole when the 300-mm boot sole is used. For other boot sole lengths the distance shall be two thirds the distance from the front of the sole.

6.4.3 The test shaft and associated instrumentation shall be capable of measuring moments about the x -, y -, and z -axes as required. Further specifications for the test shaft as part of the instrumentation system are discussed in 6.6.

6.4.4 The linear compliance of all combined mechanical components of the test frame shall be no more than 4×10^{-6} m/N in either of the x or y directions, and no more than 4×10^{-7} m/N in the z direction for loads applied at the intersection of the test shaft and the attachment plate. The angular compliance shall be no more than 5×10^{-5} rad/N · m for rotations around the x , y , or z -axes.

NOTE 1—When an associated high-speed test series is established, the angular compliance shall be no more than 2.5×10^{-5} rad/N · m for rotations around the x -, y -, or z -axes.

6.5 Cable:

6.5.1 The minimum length of cable between the point of attachment to the ski and the nearest support shall be 1 m.

6.5.2 The cable shall be attached to the ski such that the resultant force transmitted through the cable passes within 1 cm of the centroid of the cross section of the ski.

6.5.3 Preloads are applied through a pulley near the base of the load cell pedestal with an attachment swivel not more than 12 cm offset from the load cell axis. A spring with a spring

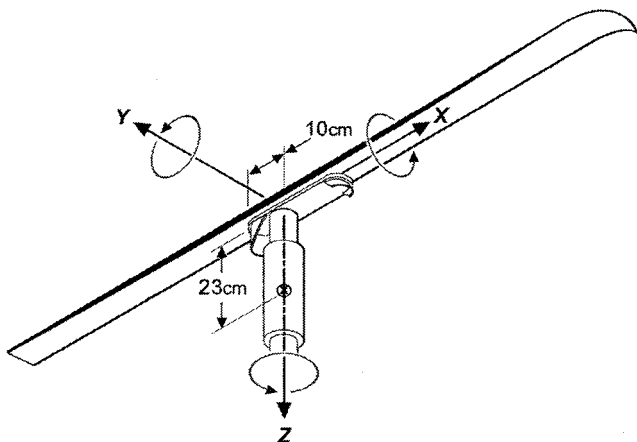

FIG. 2 Test Equipment

constant of 65 N/cm ($\pm 10\%$) and an unloaded length of at least 20 cm is attached between the preload cable and the attachment fixture. When a preload (PL) is used in a test the preload cable force will induce a moment M_y that is a specified percentage of the nominal release moment in test 2.1 (see Fig. 11).

6.5.4 Release in tests 1.1, 2.2, and 2.2 (Fig. 3, Fig. 11, and Fig. 12) is accomplished by a single cable connecting points N and R that is loaded by a traveller pulley of a design capable of applying loads at N and R that are opposite in direction and equal in magnitude to within 5% of each other.

NOTE 2—Preloads (PL) given in Figs. 7-10 are examples of M_y preload moments that may be specified.

6.6 Instrumentation:

6.6.1 Measurements—The instrumentation shall provide measurement of the peak M_z and M_y moments. The values of measured moments are referred to a point 23 ± 0.1 cm above the bearing surface of the boot sole on the z -axis for 300-mm sole lengths. Other length soles shall require this reference point to be shifted proportionally.

6.6.2 Range—Maximum moment along a single axis:

$$300 \text{ N} \cdot \text{m} \text{ (full-scale for } M_z M_x) \quad (1)$$

$$1000 \text{ N} \cdot \text{m} \text{ (full-scale for } M_y)$$

6.6.3 Accuracy—Absolute accuracy for moment measurements to errors less than $\pm 2\%$ of reading for readings above 50 N·m and less than $\pm 1\%$ N·m for readings 50 N·m or less.

6.6.4 Repeatability—Repeated readings under standard test conditions shall be repeatable to $\pm 1.5\%$ for moment readings above 50 N·m. Repeatability shall be to ± 0.75 N·m for lower readings.

6.6.5 Hysteresis—The hysteresis measured at no load shall be less than 1.5-N·m moment following a cyclical load to full scale.

6.6.6 Null Drift shall be correctable to less than 0.75-N·m moment at 20°C.

6.6.7 Temperature Sensitivity:

$$\text{Gain variations: correctable to } 0.2\% \text{ } ^\circ\text{C at} \quad (2)$$

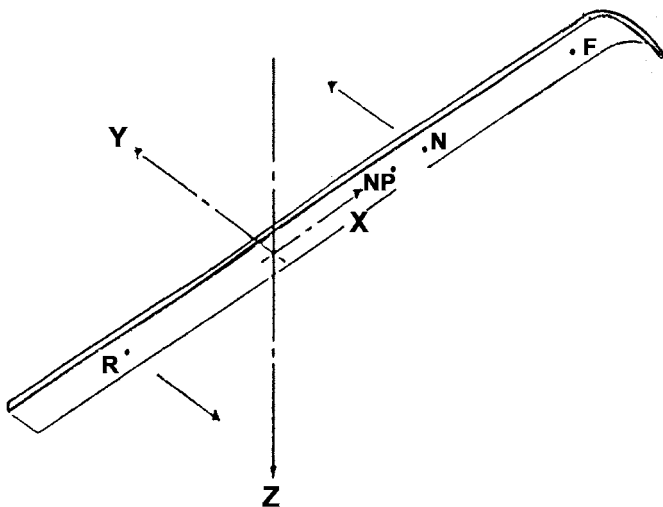

FIG. 3 Test 1.1

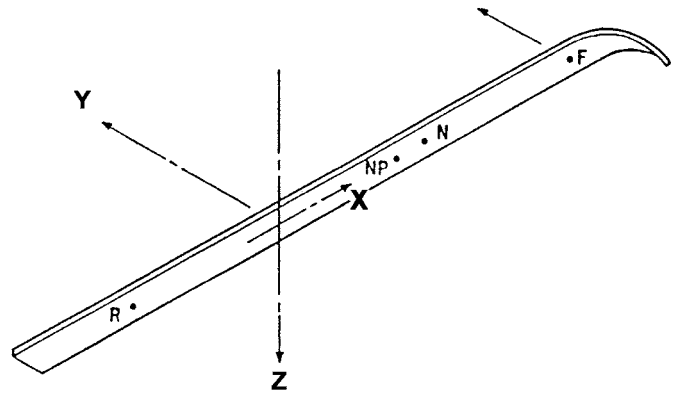

FIG. 4 Test 1.3

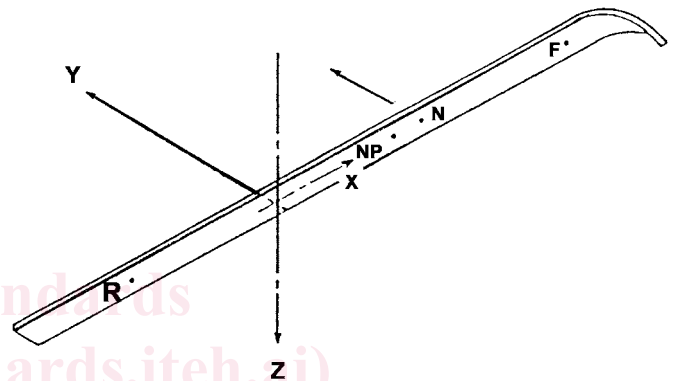

FIG. 5 Test 1.4

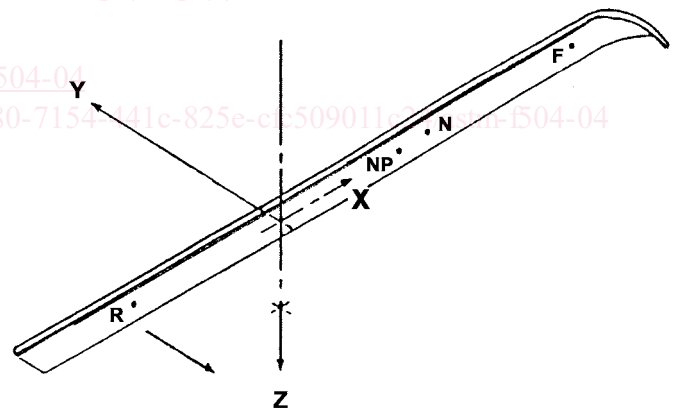

FIG. 6 Test 1.5

$$T_o \pm 0.5^\circ\text{C}$$

$$\text{Null variations: correctable to } 0.5 \text{ N} \cdot \text{m}/^\circ\text{C at} \quad (3)$$

$$T_o \pm 0.5^\circ\text{C}$$

where: T_o = equilibrium environmental temperature and is in the range from -20 to $+20^\circ\text{C}$.

6.6.8 Frequency Response—Gain measured at full scale shall vary less than 1 dB over the bandwidth 0 to 100 Hz. Phase lag shall be less than 10° over the same bandwidth.

6.7 Load Application:

6.7.1 Locations and Directions of Application—The apparatus shall have the capability of applying the load configurations in accordance with Figs. 3-15. Tests in Category 1 have

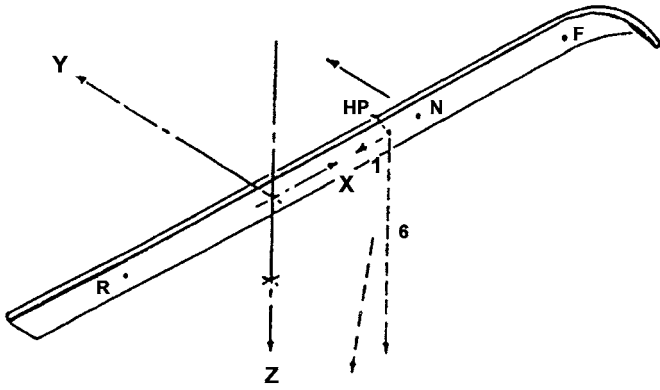

$PL = .75 \times [2.1]$
 FIG. 7 Test 1.6

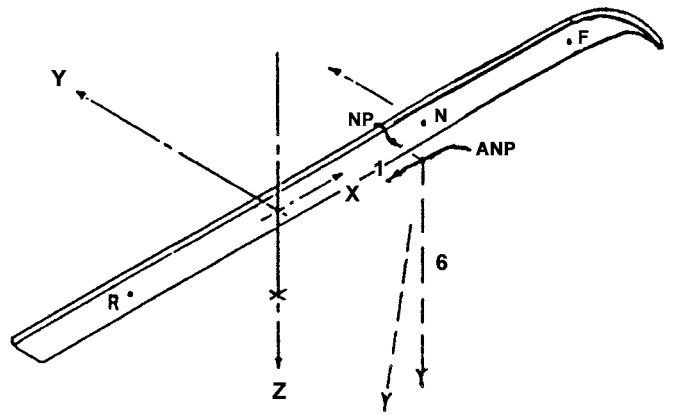

$PL = .75 \times [2.1]$
 FIG. 10 Test 1.11

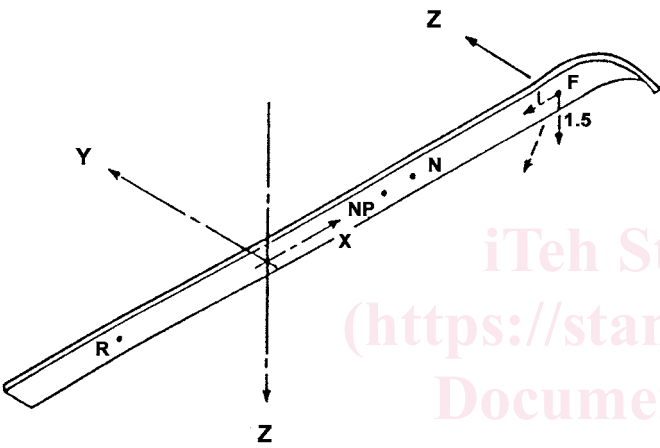

$PL = .50 \times [2.1]$
 FIG. 8 Test 1.8

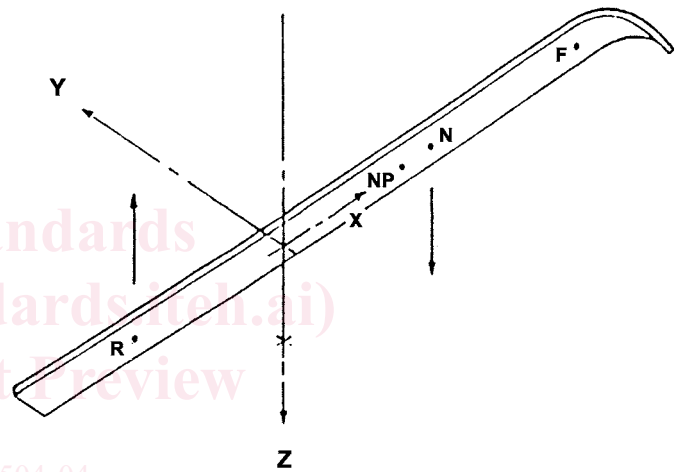
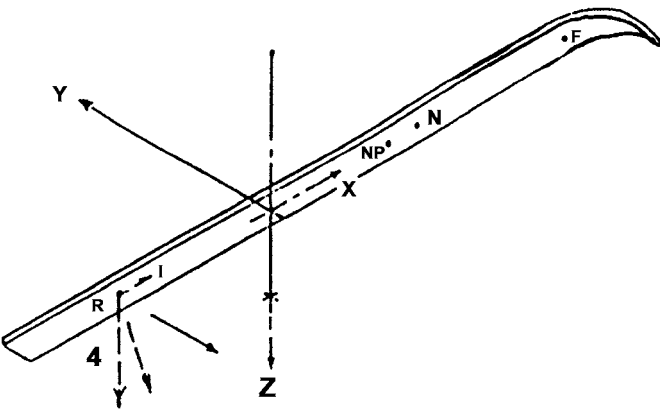

FIG. 11 Test 2.1



$PL = .50 \times [2.1]$
 FIG. 9 Test 1.10

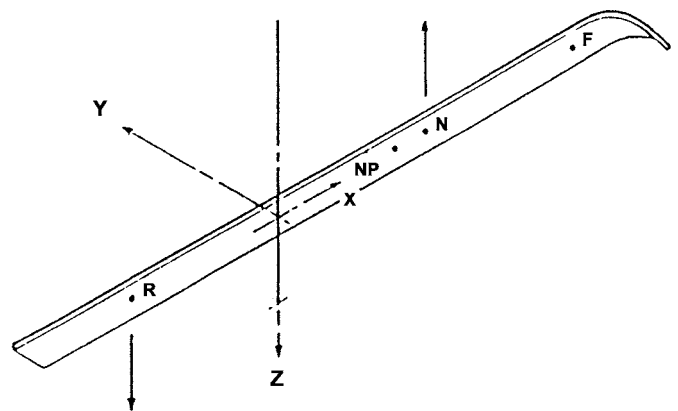

FIG. 12 Test 2.2

a significant M_z component; tests in Category 2 have a significant M_y component. Note that the unit vector is given for all loads applied through the cable system. The unit vector for a release load is shown as a solid line while the unit vector for a preload is shown as a dashed line. Preloads (PL) are given in terms of the nominal value of test 2.1 (see Fig. 11).

6.7.1.1 Release load and preload cables shall be adjustable to within 2° of the orientation of the unit vector specified in Figs. 3-15 as measured under a cable tension equivalent to approximately 10 % of the nominal release load in tests 1.1 or 2.1 as appropriate.

6.7.2 Rates of Application—The apparatus shall have the ability of applying loads such that the linear speed of the cable

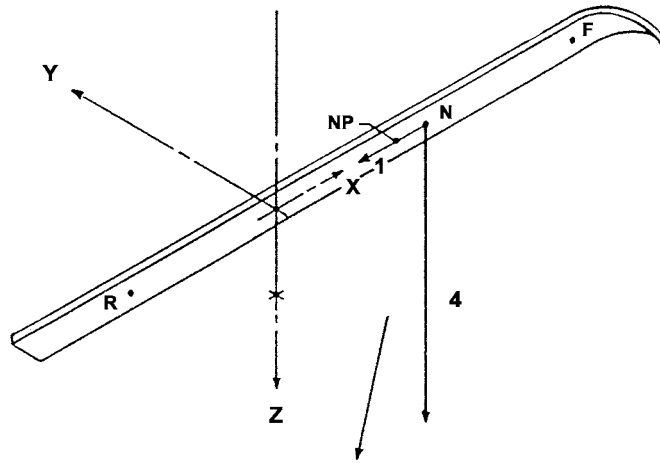

FIG. 13 Test 2.3

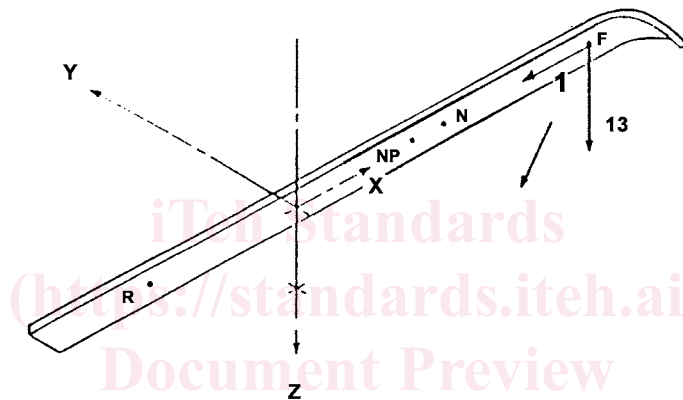

FIG. 14 Test 2.5

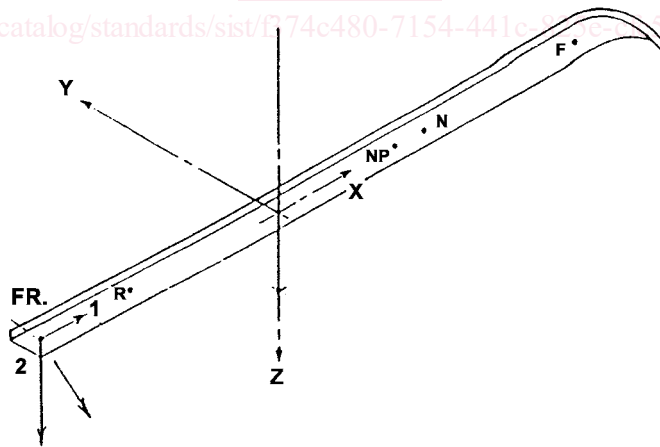

FIG. 15 Test 2.8

at the point of attachment to the ski shall be adjustable to two different rates as follows: 2 ± 0.5 cm/s and 60 ± 10 cm/s.

6.7.3 *Calibration*—The load cell is calibrated using the fixture and procedures defined in Annex A.

6.7.4 *Zeroing*—The instrumentation is zeroed without the ski attached to the test sole.

7. Test Specimen Preparation

7.1 Bindings should be mounted in accordance with the manufacturer's specifications, and boot surfaces and interfaces shall be cleaned with an appropriate cleaner, unless otherwise specified by environmental test procedures. All tests shall be

performed with boot-binding contact points wet by a mist of distilled water unless otherwise specified by environmental procedures.

8. Procedure

8.1 An individual release measurement shall consist of attaching a ski-binding system to the test apparatus and applying a load configuration, as specified in 6.7.1 and 6.7.2,

sufficient to cause the binding mechanism to release while simultaneously recording information sufficient to determine the two peak M_z and M_y moments. Refer to Annex A2 for step-by-step procedures.

9. Keywords

9.1 alpine ski binding; release binding; release envelope; release moment

ANNEXES

(Mandatory Information)

A1. FIXTURES

A1.1 Scope

A1.1.1 This Annex describes fixtures that may be used to adapt the device described in Test Method F 504 to meet the requirements of ISO 9462 Method B.

A1.2 Fixtures and Test Configurations

A1.2.1 Use the ski stiffening fixture described in Fig. A1.1 and release loads as defined in Fig. 3 and Fig. 11 unless otherwise specified.

A1.2.2 To perform the release with ski deflection test, use the fixture described in Fig. A1.2.

A1.2.3 To perform the release with combined loading test for influence of forward lean of the body, use the load configuration defined in Fig. A1.3 to apply the preload moment M_y .

A1.2.4 To perform the release with combined loading test for influence of roll loading, use the fixture described in Fig. A1.4 to apply the preload moment M_x .

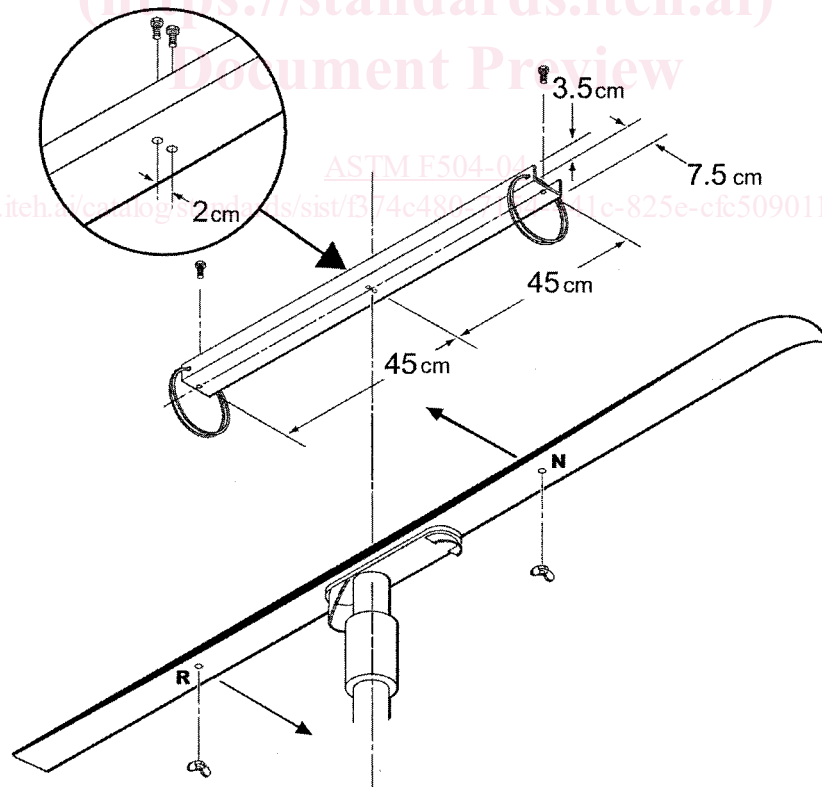

FIG. A1.1 Ski Stiffening Fixture