**Plastics — Determination of temperature
of deflection under load —**

Part 1:

General test method

(standards.iteh.ai)

*Plastiques — Détermination de la température de fléchissement sous
charge —*

<https://standards.iteh.ai/catalog/standards/sist/28750793-2a95-4d65->

Partie 1: Méthode générale d'essai



Foreword

ISO (the International Organization for Standardization) is a worldwide federation of national standards bodies (ISO member bodies). The work of preparing International Standards is normally carried out through ISO technical committees. Each member body interested in a subject for which a technical committee has been established has the right to be represented on that committee. International organizations, governmental and non-governmental, in liaison with ISO, also take part in the work. ISO collaborates closely with the International Electrotechnical Commission (IEC) on all matters of electrotechnical standardization.

Draft International Standards adopted by the technical committees are circulated to the member bodies for voting. Publication as an International Standard requires approval by at least 75 % of the member bodies casting a vote.

International Standard ISO 75-1 was prepared by Technical Committee ISO/TC 61, *Plastics*, Sub-Committee SC 2, *Mechanical properties*.

Together with the other parts, it cancels and replaces the second edition of ISO 75 (ISO 75:1987), which has been technically revised.

ISO 75 consists of the following parts, under the general title *Plastics* — *Determination of temperature of deflection under load*:

- Part 1: *General test method*
- Part 2: *Plastics and ebonite*
- Part 3: *High-strength thermosetting laminates and long-fibre-reinforced plastics*

© ISO 1993

All rights reserved. No part of this publication may be reproduced or utilized in any form or by any means, electronic or mechanical, including photocopying and microfilm, without permission in writing from the publisher.

International Organization for Standardization
Case Postale 56 • CH-1211 Genève 20 • Switzerland

Printed in Switzerland

Plastics — Determination of temperature of deflection under load —

Part 1: General test method

1 Scope

ISO 291:1977, *Plastics — Standard atmospheres for conditioning and testing*.

1.1 ISO 75 specifies methods for the determination of the temperature of deflection under load (bending stress under three-point loading) of different types of material.

1.2 Part 1 of ISO 75 gives a general test method, part 2 gives specific requirements for plastics and ebonite and part 3 gives specific requirements for high-strength thermosetting laminates and long-fibre-reinforced plastics.

1.3 The methods specified are suitable for assessing the behaviour of the different types of material at elevated temperature under load at a specified rate of temperature increase. The results obtained do not necessarily represent maximum use temperatures, because in practice essential factors such as time, loading conditions and nominal surface stress may differ from the test conditions.

2 Normative reference

The following standard contains provisions which, through reference in this text, constitute provisions of this part of ISO 75. At the time of publication, the edition indicated was valid. All standards are subject to revision, and parties to agreements based on this part of ISO 75 are encouraged to investigate the possibility of applying the most recent edition of the standard indicated below. Members of IEC and ISO maintain registers of currently valid International Standards.

3 Definitions

For the purposes of this and the other parts of ISO 75, the following definitions apply.

3.1 deflection: The distance, at mid-span, over which the top or bottom surface of a test specimen deviates, during flexure, from its original position. It is expressed in millimetres.

3.2 standard deflection s : The deflection which will result in the flexural strain, at the surface of the test specimen, which is specified in the relevant part of this International Standard. The standard deflection depends on the dimensions and position of the test specimen and the span between the supports. It is expressed in millimetres.

3.3 temperature of deflection under load, T_f : The temperature at which the deflection of the test specimen reaches the standard deflection as the temperature is increased. It is expressed in degrees Celsius.

3.4 flexural strain: The nominal fractional change in length of an element at the surface of the test specimen at mid-span. It is expressed as a dimensionless quantity.

3.5 flexural stress, σ : The nominal stress at the surface of the test specimen at mid-span. It is expressed in megapascals.

4 Principle

A standard test specimen is subjected to a bending stress to produce one of the nominal surface stresses given in the relevant part of this International Standard. The temperature is raised at a uniform rate, and the temperature at which a specified deflection occurs is measured.

5 Apparatus

5.1 Means of applying a bending stress

The apparatus shall be constructed essentially as shown in figure 1. It consists of a rigid metal frame in which a rod can move freely in the vertical direction. The rod is fitted with a weight-carrying plate and a loading edge. The base of the frame is fitted with test-specimen supports; these and the vertical members of the frame are made of a metal having the same coefficient of linear expansion as the rod.

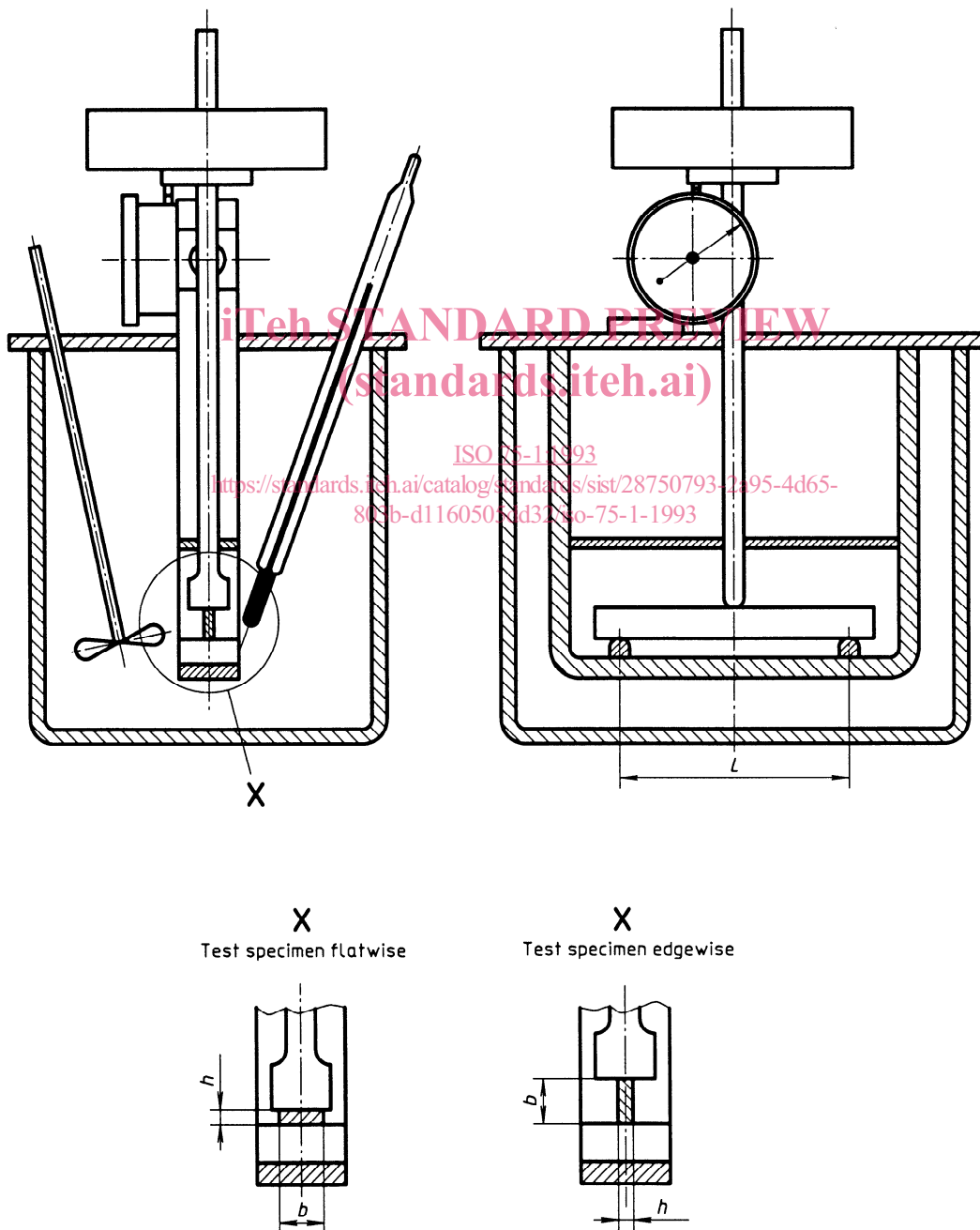

Figure 1 — Typical apparatus for determination of temperature of deflection under load

The test-specimen supports consist of cylindrical metal pieces at a distance apart defined in the relevant part of this International Standard and with their lines of contact with the specimen in a horizontal plane. The supports are fitted to the base of the frame in such a way that the vertical force applied to the test specimen by the loading edge is midway between them. The contact edges of the supports are parallel to the loading edge and at right angles to the length direction of a test specimen placed symmetrically across them. The contact edges of the supports and loading edge are rounded to a radius of $3,0 \text{ mm} \pm 0,2 \text{ mm}$ and shall be longer than the width of the test specimen.

Unless vertical parts of the apparatus have the same coefficient of linear expansion, the differential change in the length of these parts introduces an error in the reading of the apparent deflection of the test specimen. A blank test shall be made on each apparatus using a test specimen made of rigid material having a low coefficient of expansion. The blank test shall cover the temperature ranges to be used in the actual determination, and a correction term shall be determined for each temperature. If the correction term is $0,010 \text{ mm}$ or greater, its value and algebraic sign shall be noted and the term applied to each test by adding it algebraically to the reading of the apparent deflection of the test specimen.

NOTE 1 Invar and borosilicate glass have been found suitable as materials for the test specimen in the blank test.

5.2 Heating equipment

The heating equipment may be a heating bath containing a suitable liquid, a fluidized bed or an oven with forced circulation of air or nitrogen.

The heating equipment shall be provided with a control unit so that the temperature can be raised at a uniform rate of $120 \text{ }^\circ\text{C/h} \pm 10 \text{ }^\circ\text{C/h}$. This heating rate shall be considered to be met if, over every 6-min interval during the test, the temperature change is $12 \text{ }^\circ\text{C} \pm 1 \text{ }^\circ\text{C}$.

The difference in the temperature of the heat-transfer medium between the ends and the centre of the test specimen shall not exceed $1 \text{ }^\circ\text{C}$.

The apparatus may be designed to stop heating automatically and sound an alarm when the specified deflection has been reached.

NOTE 2 The heat-transfer media given above vary in their thermal conductivity. To prevent significant errors in the results, the thermometer or other temperature-measuring instrument used must be carefully adjusted in accordance with 8.2.

5.2.1 Heating bath, containing a suitable liquid in which the test specimen can be immersed to a depth of at least 50 mm . An efficient stirrer shall be provided. It shall be established that the liquid chosen is

stable over the temperature range used and does not affect the material under test, for example causing it to swell or crack.

NOTE 3 Liquid paraffin, transformer oil, glycerol and silicone oils are suitable liquid heat-transfer media, but other liquids may be used.

5.2.2 Oven, with forced air or nitrogen circulation of about 60 times per minute; with a volume of not less than 10 litres per specimen holder (see 5.1), and with the air or nitrogen flow directed horizontally, perpendicular to the length of the specimen, at a speed of $1,5 \text{ m/s}$ to 2 m/s .

NOTE 4 Commercially available ovens are often fitted with suitable air or nitrogen circulation equipment. If not, the necessary heat-transfer conditions may be ensured by fitting guide-vanes to direct the air or nitrogen flow horizontally across the specimen.

5.3 Weights

A set of weights shall be provided so that the test specimen can be loaded to the required nominal surface stress, calculated as specified in 8.1.

NOTE 5 It may be necessary to adjust these weights in 1 g increments.

5.4 Temperature-measuring instrument

This may be a mercury-in-glass thermometer of the partial-immersion type, or any other suitable temperature-measuring instrument, with an appropriate range and reading to $0,5 \text{ }^\circ\text{C}$ or less. Mercury-in-glass thermometers shall be calibrated at the depth of immersion required by 8.2.

5.5 Deflection-measuring instrument

This may be a calibrated micrometer dial gauge, or any other suitable measuring instrument, capable of measuring to $0,01 \text{ mm}$ the deflection at the midpoint between the test-specimen supports.

NOTE 6 In certain types of apparatus, the force F_s exerted by the dial gauge spring acts upwards and therefore reduces the downward force exerted by the weighted rod, while, in other types, F_s acts downwards and augments that exerted by the weighted rod. In such cases, it is necessary to determine the magnitude and direction of F_s so as to be able to compensate for it (see 8.1).

Since, in certain dial gauges, F_s varies considerably over the range of the instrument, it should be measured in that part of the range in which the instrument is to be used.

5.6 Micrometers and gauges

These are used to measure the main dimensions of the test specimens. They shall be accurate to $0,01 \text{ mm}$.

6 Test specimens

At least two test specimens shall be used for each sample. Each test specimen shall be a bar of rectangular cross-section (length l , width b , thickness h).

The dimensions of the test specimens shall be as specified in the relevant part of this International Standard, the thickness always being smaller than the width (i.e. $h < b$). All test specimens shall be free of warpage.

In each test specimen, the thickness and width over the central one-third of the length shall nowhere deviate by more than 2 % from the mean value.

7 Conditioning

Unless otherwise required by the specification for the material being tested, the atmosphere used for conditioning and testing shall be in accordance with ISO 291.

8 Procedure

8.1 Calculation of force to be applied

In the three-point loading method employed in this International Standard, the force applied to the specimen is given, in newtons, as a function of the flexural stress by one of the following equations:

$$F = \frac{2\sigma \cdot b \cdot h^2}{3L}$$

when the test specimen is in the flatwise position:

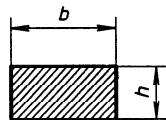

and

$$F = \frac{2\sigma \cdot h \cdot b^2}{3L}$$

when the test specimen is in the edgewise position:

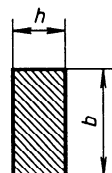

where

σ is the maximum nominal surface stress, in megapascals, in the test specimen;

b is the width, in millimetres, of the test specimen;

h is the thickness, in millimetres, of the test specimen;

L is the span, in millimetres, between the test-specimen supports.

Measure dimensions b and h to the nearest 0,1 mm and dimension L to the nearest 0,5 mm.

The span between the test specimen supports and the nominal surface stress shall be as specified in the relevant part of this International Standard.

The effect of the mass m_r of the rod that applies the test force F shall be taken into account as contributing to the test force. If a spring-loaded instrument such as a dial gauge is used, the magnitude and direction of the force F_s exerted by the spring shall also be taken into account as a positive or negative contribution to the force F (see 5.5, note 6).

The mass m_w of any additional weights which need to be placed on the rod to produce the required total force F is given by the equation

$$F = 9,81(m_w + m_r) + F_s$$

from which

$$m_w = \frac{F - F_s}{9,81} - m_r$$

where

m_r is the mass, in kilograms, of the rod assembly that applies the test force;

m_w is the mass, in kilograms, of the additional weights;

F is the total force, in newtons, applied to the test specimen;

F_s is the force, in newtons, exerted by any spring-loaded instrument used; the value of the force is positive if the thrust of the spring is directed towards the test specimen (i.e. downwards), negative if the thrust of the spring is in the opposite direction (i.e. opposing the descent of the rod) or zero if no such instrument is used.

The actual force applied shall be the calculated force $F \pm 2,5$ %.

8.2 Initial temperature of the heating equipment

The thermometer bulb or the sensor element of the temperature-measuring instrument (5.4) shall be at the same level as, and as close as possible to, the test specimen (within 10 mm), but not in contact with it. The temperature of the heating equipment (5.2) shall be between 20 °C and 23 °C at the start of each test, unless previous tests have shown that, for the particular material under test, no error is introduced by starting at some other temperature.

8.3 Measurement

Check and, if necessary, adjust the span between the test-specimen supports (see 5.1) to the appropriate value. Measure this distance to the nearest 0,5 mm and record for use in the calculations in 8.1.

Place a test specimen on the supports so that the longitudinal axis of the specimen is perpendicular to the supports. Place the loading assembly (5.1) in the heat-transfer medium. Apply the force calculated in 8.1 to give a nominal surface stress in the test specimen as specified in the relevant part of this International Standard. Allow the force to act for 5 min (see note 7). Record the reading of the deflection-measuring instrument (5.5) or set it to zero.

Raise the temperature of the heating equipment at a uniform rate of $120\text{ °C/h} \pm 10\text{ °C/h}$. Note the temperature at which the bar reaches the standard deflection, i.e. the temperature of deflection under load at the nominal surface stress specified in the relevant part of this International Standard. The standard deflection is a function of the height (h or b , depending on the orientation of the test specimen, see 8.1) and is given in the relevant part of this International Standard.

NOTES

7 The 5-min waiting period is provided to compensate partially for the creep exhibited by some materials at room temperature when subjected to the specified nominal surface stress. The creep which occurs in the first 5 min is usually a significant fraction of that which occurs in the first 30 min. This waiting period may be omitted when testing materials that show no appreciable creep during the first 5 min at the initial temperature used.

8 It is frequently helpful in the interpretation of test results if specimen deflection is known as a function of specimen temperature. It is thus recommended that, where possible, the specimen deflection be monitored continuously during the waiting and heating periods.

The test shall be carried out at least in duplicate. Each test specimen shall be used only once.

9 Expression of results

Unless otherwise specified in the relevant part of this International Standard, express the temperature of deflection under load of the material under test as the arithmetic mean of the temperatures of deflection under load of the specimens tested.

10 Precision

The precision of this test method is not known because inter-laboratory data are not available. When such data are obtained, a precision statement will be added at the next revision.

11 Test report

The test report shall include the following information:

- a) a reference to the relevant part of this International Standard;
- b) all details necessary for the identification of the material tested;
- c) the method of preparation of the test specimens;
- d) the heat-transfer medium used;
- e) the conditioning and annealing procedures used, if any;
- f) the temperature of deflection under load, in degrees Celsius (if the individual results of two measurements differ by more than the limit given in the relevant part of this International Standard, all individual results shall be reported);
- g) the dimensions of the test specimens used;
- h) the orientation of the test specimen (flatwise or edgewise);
- i) the nominal surface stress used;
- j) the span between the test-specimen supports;
- k) any unusual behaviour of the test specimen noted during the test or after removal from the apparatus.

iTeh STANDARD PREVIEW
(standards.iteh.ai)

ISO 75-1:1993

<https://standards.iteh.ai/catalog/standards/sist/28750793-2a95-4d65-803b-d1160505dd32/iso-75-1-1993>

UDC 678.[5/.8].01:620.174.22

Descriptors: plastics, tests, high temperature tests, bend tests, determination, mechanical properties, deflection, test equipment, generalities.

Price based on 5 pages
