



## DRAFT INTERNATIONAL STANDARD ISO/DIS 3691-2.2

ISO/TC 110/SC 2

Secretariat: BSI

Voting begins on:  
2006-02-23

Voting terminates on:  
2006-07-23

INTERNATIONAL ORGANIZATION FOR STANDARDIZATION • МЕЖДУНАРОДНАЯ ОРГАНИЗАЦИЯ ПО СТАНДАРТИЗАЦИИ • ORGANISATION INTERNATIONALE DE NORMALISATION

## Industrial trucks — Safety requirements and verification —

### Part 2:

### Self-propelled variable-reach trucks

*Chariots de manutention — Exigences de sécurité et vérification —*

*Partie 2: Chariots automoteurs à portée variable*

(Revision of ISO 3691:1980)

**STANDARD PREVIEW**  
(standards.iteh.ai)

ICS 53.060

<https://standards.iteh.ai/catalog/standards/sist/2a73751a-4ec4-9aca-2c90-600000000000/iso-dis-3691-2.2>

#### ISO/CEN PARALLEL ENQUIRY

The CEN Secretary-General has advised the ISO Secretary-General that this ISO/DIS covers a subject of interest to European standardization. **In accordance with the ISO-lead mode of collaboration as defined in the Vienna Agreement, consultation on this ISO/DIS has the same effect for CEN members as would a CEN enquiry on a draft European Standard.** Should this draft be accepted, a final draft, established on the basis of comments received, will be submitted to a parallel two-month FDIS vote in ISO and formal vote in CEN.

**To expedite distribution, this document is circulated as received from the committee secretariat. ISO Central Secretariat work of editing and text composition will be undertaken at publication stage.**

**Pour accélérer la distribution, le présent document est distribué tel qu'il est parvenu du secrétariat du comité. Le travail de rédaction et de composition de texte sera effectué au Secrétariat central de l'ISO au stade de publication.**

THIS DOCUMENT IS A DRAFT CIRCULATED FOR COMMENT AND APPROVAL. IT IS THEREFORE SUBJECT TO CHANGE AND MAY NOT BE REFERRED TO AS AN INTERNATIONAL STANDARD UNTIL PUBLISHED AS SUCH.

IN ADDITION TO THEIR EVALUATION AS BEING ACCEPTABLE FOR INDUSTRIAL, TECHNOLOGICAL, COMMERCIAL AND USER PURPOSES, DRAFT INTERNATIONAL STANDARDS MAY ON OCCASION HAVE TO BE CONSIDERED IN THE LIGHT OF THEIR POTENTIAL TO BECOME STANDARDS TO WHICH REFERENCE MAY BE MADE IN NATIONAL REGULATIONS.

**PDF disclaimer**

This PDF file may contain embedded typefaces. In accordance with Adobe's licensing policy, this file may be printed or viewed but shall not be edited unless the typefaces which are embedded are licensed to and installed on the computer performing the editing. In downloading this file, parties accept therein the responsibility of not infringing Adobe's licensing policy. The ISO Central Secretariat accepts no liability in this area.

Adobe is a trademark of Adobe Systems Incorporated.

Details of the software products used to create this PDF file can be found in the General Info relative to the file; the PDF-creation parameters were optimized for printing. Every care has been taken to ensure that the file is suitable for use by ISO member bodies. In the unlikely event that a problem relating to it is found, please inform the Central Secretariat at the address given below.

**iTeh STANDARD PREVIEW  
(standards.iteh.ai)**

[ISO/DIS 3691-2.2](https://standards.iteh.ai/catalog/standards/sist/2c72e780-851a-4ec4-9aea-2c9d340d1c2d/iso-dis-3691-2-2)

<https://standards.iteh.ai/catalog/standards/sist/2c72e780-851a-4ec4-9aea-2c9d340d1c2d/iso-dis-3691-2-2>

**Copyright notice**

This ISO document is a Draft International Standard and is copyright-protected by ISO. Except as permitted under the applicable laws of the user's country, neither this ISO draft nor any extract from it may be reproduced, stored in a retrieval system or transmitted in any form or by any means, electronic, photocopying, recording or otherwise, without prior written permission being secured.

Requests for permission to reproduce should be addressed to either ISO at the address below or ISO's member body in the country of the requester.

ISO copyright office  
Case postale 56 • CH-1211 Geneva 20  
Tel. + 41 22 749 01 11  
Fax + 41 22 749 09 47  
E-mail [copyright@iso.org](mailto:copyright@iso.org)  
Web [www.iso.org](http://www.iso.org)

Reproduction may be subject to royalty payments or a licensing agreement.

Violators may be prosecuted.

**Contents**

Page

<b>Foreword</b> .....	<b>iv</b>
<b>Introduction</b> .....	<b>v</b>
<b>1 Scope</b> .....	<b>1</b>
<b>2 Normative references</b> .....	<b>1</b>
<b>3 Terms and definitions</b> .....	<b>2</b>
<b>4 List of significant hazards</b> .....	<b>5</b>
<b>5 Requirements</b> .....	<b>12</b>
<b>6 Verification of requirements and safety measures</b> .....	<b>24</b>
<b>7 Information for use</b> .....	<b>25</b>
<b>Annex A (informative) Rated capacity of truck</b> .....	<b>33</b>
<b>Annex ZA (informative) Relationship between this International Standard and the Essential Requirements of EU Directive 98/37/EC, amended by Directive 98/79/EC</b> .....	<b>37</b>

**iTeh STANDARD PREVIEW**  
**(standards.iteh.ai)**

[ISO/DIS 3691-2.2](https://standards.iteh.ai/catalog/standards/sist/2c72e780-851a-4ec4-9aea-2c9d340d1c2d/iso-dis-3691-2-2)

<https://standards.iteh.ai/catalog/standards/sist/2c72e780-851a-4ec4-9aea-2c9d340d1c2d/iso-dis-3691-2-2>

## Foreword

ISO (the International Organization for Standardization) is a worldwide federation of national standards bodies (ISO member bodies). The work of preparing International Standards is normally carried out through ISO technical committees. Each member body interested in a subject for which a technical committee has been established has the right to be represented on that committee. International organizations, governmental and non-governmental, in liaison with ISO, also take part in the work. ISO collaborates closely with the International Electrotechnical Commission (IEC) on all matters of electrotechnical standardization.

International Standards are drafted in accordance with the rules given in the ISO/IEC Directives, Part 2.

The main task of technical committees is to prepare International Standards. Draft International Standards adopted by the technical committees are circulated to the member bodies for voting. Publication as an International Standard requires approval by at least 75 % of the member bodies casting a vote.

Attention is drawn to the possibility that some of the elements of this document may be the subject of patent rights. ISO shall not be held responsible for identifying any or all such patent rights.

ISO 3691-2 was prepared by Technical Committee ISO/TC 110, *Industrial trucks*, Subcommittee SC 2.

This edition cancels and replaces the second edition (ISO 3691:1980), which has been technically revised.

ISO 3691 consists of the following parts, under the general title *Industrial trucks — Safety requirements and verification*:

- *Part 1: Self propelled industrial trucks, other than driverless and variable reach trucks, and burden carriers*
- *Part 2: Self propelled variable reach trucks*
- *Part 3: Additional requirements for trucks with elevating operator position and trucks specifically designed to travel with elevated loads*
- *Part 4: Driverless industrial trucks and their systems*
- *Part 5: Pedestrian propelled trucks*
- *Part 6: Burden and personnel carriers*

## Introduction

### 0.1 General

This International Standard covers safety requirements and verification of industrial trucks as defined in Standard ISO 5053 - Terminology.

For the purpose of this Standard, industrial trucks are wheeled self propelled or manually driven vehicles, except those running on rails. They are either operator controlled or driverless and are designed to carry, tow, push, lift, stack or tier in racks.

### 0.2 Structure

An important step forward within the work for this standard was the agreement to issue a new structure of International Standards for industrial trucks having on one side basic standards for all kinds of trucks (see Foreword) and on the other side independent standards to cover the respective specific functions of industrial trucks e.g. visibility, noise, vibration, electrical requirements etc.

### 0.3 Assessment of hazards

The product should be designed in such a way that it is fit for its purpose or function and can be adjusted and maintained without putting persons at risk when it is used under conditions foreseen by the manufacturer.

In order to properly design a product and to cover all specific safety requirements, the manufacturer should identify the hazards that apply to his product and should carry out a risk assessment. He then should design and construct it taking account of this assessment.

The aim of this procedure is to eliminate the risk of accidents throughout the foreseeable lifetime of the machinery including the phases of assembling and dismantling where risks of accidents could also arise from foreseeable abnormal situations.

In selecting the most appropriate methods the manufacturer should apply the following principles in the order given:

- Eliminate or reduce risks as far as possible by design (inherently safe machinery design and construction);
- take the necessary protection measures in relation to risks that can not be eliminated by design;
- inform users of the residual risks due to any shortcoming of the protection measures adopted;
- indicate whether any particular training is required and;
- specify any need to provide personal protection equipment.

The machinery should be designed to prevent abnormal use, wherever possible, if such would engender risk. In other cases the instructions should draw the user's attention to ways – which experience has shown might occur – in which the machinery should not be used.

A list of hazards is given in clause 4 of each part of the standard. The list provides guidance on appropriate measures to protect against the risks involved.

#### 0.4 Legislative situation/Vienna Agreement

From the very beginning, the task of the working group was to revise the standard and to establish world wide basic standards to comply with the major legislative regulations in the world, e.g. EU, USA and Japan.

For several potential problem areas compromises were needed and will be needed in the future.

In order to ensure that the revised ISO Standard is actively used in the ISO countries world wide, procedures are necessary to replace the existing national standards and technical regulations by the revised ISO Standard. In the European Community ISO and the European Committee for Standardization (CEN) agreed on technical co-operation between ISO and CEN (Vienna Agreement) with the aim to replace the European Standards (EN) by the later worldwide ISO standards by using the parallel voting procedure automatically. Other countries are asked to issue similar agreements to ensure that their national standards and technical regulations are replaced by this ISO Standard.

Only by these actions there will be the guarantee that products in accordance with the ISO standards could be shipped world wide freely without any technical barriers.

**iTeh STANDARD PREVIEW**  
**(standards.iteh.ai)**

[ISO/DIS 3691-2.2](https://standards.iteh.ai/catalog/standards/sist/2c72e780-851a-4ec4-9aea-2c9d340d1c2d/iso-dis-3691-2-2)

<https://standards.iteh.ai/catalog/standards/sist/2c72e780-851a-4ec4-9aea-2c9d340d1c2d/iso-dis-3691-2-2>

# Industrial trucks — Safety requirements and verification —

## Part 2:

## Self-propelled variable-reach trucks

### 1 Scope

1.1 This part of 3691 applies to self-propelled seated rider operated variable reach trucks equipped with load handling devices for normal industrial duties, e.g. fork arms or platforms, or attachments for specified applications mounted directly on non-slewing lifting means or an auxiliary mast fixed at the end of the lifting means.

Fork arms, load platforms and integrated attachments are considered to be parts of the industrial truck.

NOTE Trucks can be equipped with stabilizers, axle locking or lateral levelling devices.

Attachments mounted on the load carrier or on the fork arms which are removable, by the user are not considered to be part of the industrial truck.

For attachments the appropriate clauses of this standard are applicable.

1.2 This part of 3691 does not apply to:

Rough terrain variable reach trucks

[ISO/DIS 3691-2.2](https://standards.iteh.ai/catalog/standards/sist/2c72e780-851a-4ec4-9aea-916301b2164c/iso-dis-3691-2)

<https://standards.iteh.ai/catalog/standards/sist/2c72e780-851a-4ec4-9aea-916301b2164c/iso-dis-3691-2>

Machines designed primarily for earth moving, such as loaders and dozers, even though their buckets and blades are replaced with forks.

Machines with variable length load suspension elements (chain, ropes, etc.) from which the load may swing freely in all directions

This part of ISO 3691 does not cover those requirements to reduce hazards which may occur:

- a) during construction;
- b) when handling suspended loads which may swing freely;
- c) when using trucks on public roads;
- d) when operating in potentially explosive atmospheres;
- e) from noise, vibration and electromagnetic compatibility

### 2 Normative references

The following referenced documents are indispensable for the application of this document. For dated references, only the edition cited applies. For undated references, the latest edition of the referenced document (including any amendments) applies.

ISO/DIS 21281, *Construction and layout of pedals of self-propelled industrial trucks; sit-down rider-controls*

ISO/FDIS 13849-1:1999, *Safety of machinery — Safety related parts of control systems general principles for design*

ISO 2330:1995, *Fork lift trucks — Fork arms — Technical characteristics and testing*

ISO/DIS 2867:2001, *Earth-moving machinery — Safety requirements — Access systems*

ISO/FDIS 3287, *Powered industrial trucks — Symbols for operator controls and other displays*

ISO 3411:1995, *Earth-moving machinery — Human physical dimensions of operators and minimum operator space envelope*

ISO/DIS 3449:2002, *Earth-moving machinery — Falling-object protective structures — Laboratory tests and performance requirements*

ISO 5053:1995, *Powered industrial trucks — Terminology*

ISO 5353:1978, *Earth moving machinery and tractors and machinery for agriculture and forestry — Seat index point*

ISO 6055:1997, *High-lift rider trucks — Overhead guards — Specification and testing*

ISO 6292:1996, *Powered industrial trucks — Brake performance and component strength*

ISO 9533:1989, *Earth-moving machinery — Machine mounted forward and reverse audible warning alarm — Sound test method*

ISO 668: 1995, *Series 1 freight containers — Classification, dimensions and ratings*

ISO 5010: 1992, *Earth moving machinery — Rubber tyred machines — Steering requirements*

ISO/DIS 3874, *Series 1 freight containers — Handling and securing*

ISO 10658:1996, *Industrial trucks operating in special conditions of stacking with the load laterally displaced by powered devices — Additional stability tests*

ISO/DIS 13284, *Fork lift trucks — Fork arm extensions and telescopic for arms — Technical characteristics and strength requirements.*

ISO/DIS 13562-1, *Industrial variable reach trucks — Part 1: Stability tests*

ISO/DIS 13562-2, *Industrial variable reach trucks — Part 2: Additional stability tests for trucks handling freight containers of 6 m length and above*

ISO/DIS 13564, *Test methods for measuring visibility from self propelled trucks.*

ISO/DIS 15870, *Powered industrial trucks — Safety signs and hazard pictorials — General principles*

### 3 Terms and definitions

For the purposes of this standard, the terms and definitions of the main truck components given in ISO 5053 together with the following apply.

#### 3.1

##### **self-propelled seated rider operated variable reach trucks**

self-propelled seated rider operated variable reach trucks (hereinafter referred to as “trucks”) are counterbalanced lift trucks with one or more articulated arms, telescopic or not, non-slewing, as defined in ISO 5053, clause 4.13.2.2.2 used for stacking loads.



**3.2****capacity of truck**

load in kg (depending on lift height and/or forward reach, attachment and load centre distance) specified by the manufacturer, taking into account the stability test results and as indicated by the load chart

**3.3****capacity at maximum lift height with forks**

maximum load "Q2" in kg, specified by the manufacturer, that the truck is capable of lifting to its maximum height in normal conditions.

NOTE It is equal to the maximum load "Q2" with centre of gravity "G" (see Figure A.1), carried on the fork arms at the standard load centre "D" as specified in A.1 and with the boom adjusted to its maximum height

**3.4****capacity at maximum lift height with spreader**

maximum load "Q2" in kg, specified by the manufacturer, that the truck is capable of lifting to its maximum height in normal conditions.

NOTE It is equal to the maximum load "Q2" with centre of gravity "G" (see Figure A.2), carried using a spreader at the standard load centre distance as specified in A.2.2 and with the boom adjusted to its maximum height

**3.5****capacity at maximum forward reach with forks**

maximum load "Q3" in kg, specified by the manufacturer that the truck is capable of lifting to its maximum forward reach in normal conditions.

NOTE It is equal to the maximum load "Q3" with centre of gravity "G" (see Figure A.1), carried on the fork arms at the standard load centre "D" as specified in A.2.1 and with the boom adjusted to its maximum forward reach

**3.6****capacity at maximum forward reach with spreader**

maximum load "Q3" in kg, specified by the manufacturer that the truck is capable of lifting to its maximum forward reach in normal conditions.

NOTE It is equal to the maximum load "Q3" with centre of gravity "G" (see Figure A.2), carried using a spreader at the standard load centre distance as specified in A.2.2 and with the boom adjusted to its maximum forward reach

**3.8****capacity with stabilisers in use (if equipped)**

maximum load in kg, specified by the manufacturer that the truck is capable of lifting in 3.2.1 and 3.2.4 with the stabilisers in use

**3.9****transport height, industrial variable reach trucks**

the height from the ground to the upper face of the fork blades or to the underside of the load being between 100 to 300 mm

**3.10****rated capacity of removable attachments**

maximum load in kg that the attachment is permitted by its manufacturer to handle in normal operation under specified conditions.

NOTE For carriages, this does not include the capacity of the forks

**3.11****axle locking**

mechanism designed to stop oscillation of the rear axle to improve truck stability

**3. 12**

**stabilizer**

extendable or pivoting mechanical supports used to improve stability of a stationary truck

**3. 13**

**lateral levelling**

changing the angular relationship between the boom pivot and the ground in order to adjust the boom pivot to horizontal when the truck is standing on a side slope.

NOTE This is to ensure the boom operates in a vertical plane

**3. 14**

**fork arms**

a device including two or more solid fork arms (hook mounted or shaft mounted) which is fitted on the carriage and usually spread manually

**3. 15**

**fork arm extensions**

devices fitted over the fork arms to increase their length

**3. 16**

**boom**

the pivoting support member providing the guideways that permits horizontal and/or vertical movement of the load engaging means

**3. 17**

**spreader**

a device fitted to the boom and designed to connect the lifting points of freight containers, swap bodies and semi-trailers.

NOTE It may have powered devices to connect the lifting points of the load and an articulated mechanism to facilitate engagement

ISO/DIS 3691-2  
<https://standards.iTech.ai/catalog/standards/sist/2c72e780-851a-4ec4-9aea-2e9d340d1c2d/iso-dis-3691-2-2>

**3. 18**

**side grabs**

a device comprising two plates clamping uniform loads (boxes, cartons, barrels, blocks etc.) horizontally

**3. 19**

**wood grab**

a device designed for handling logs or round timber

**3.20**

**bucket**

a device intended to carry bulk products such as sand, gravel, coal etc

**3.21**

**overhead guard**

a device fitted to the truck for the purpose of protecting the operator against falling objects

**3.22**

**load backrest**

that portion of the fork carriage serving to restrain the load when the load is tilted rearward or upward

**3.23**

**load stabilizer**

a device clamping the load vertically and stabilizing it to prevent it from falling particularly when the truck is travelling over adverse terrain

**3.24****load push pull**

a device enabling the load to be slid forward or backwards on the fork arms

**3.25****normal operating position**

a position in which the operator shall be capable of controlling all the operating and load handling functions.

NOTE Other positions may prove necessary if it is not possible to control all the functions of the truck from a single position.

**3.26****forward travel**

forward direction of travel occurs when the load handling means is leading the travel motion of the truck

**3.27****front and rear ends of truck**

the front end of a truck is that which leads in the forward direction of travel described in 3.22.

NOTE The rear end of a truck is that which trails

**3.28****quick fastening device**

a device fitted at the end of the boom to connect and lock interchangeable attachments without the use of a tool

**3.29****auxiliary mast**

a mast at the end of the boom intended to reach greater lifting heights

**3.30****non-slewing**

having a slewing movement not greater than 5° either side of the longitudinal axis of the truck (see Figure 1)

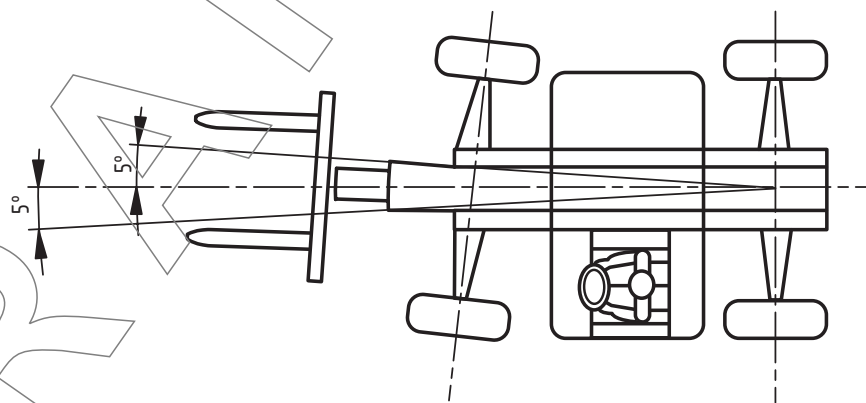

Figure 1 — Slewing movement

## 4 List of significant hazards

The following hazards may be applicable and could involve risks to persons if not addressed. The corresponding requirements offer guidance to limit the risk or reduce these hazards.

	Hazard	Corresponding requirement
4.1	Mechanical hazards	
4.1.1	Crushing hazard	5.3 Brakes 5.4 Controls 5.5.4 Access to engine and other compartments 5.7 Operator position 5.7.4 Guards for wheels 5.7.6 Protection against crushing, shearing and trapping 5.7.7 Operator restraint 5.9.1 Overhead guard 5.9.2 Warning device 5.10.1 Visibility 5.11.1 Operator's cab 5.11.4.2 Provisions for transport of the truck and removable attachments 5.12 Systems for towing 7.2.2 Operation of the truck and/or attachment(s)
4.1.2	Shearing hazard	7.3.4.5 Warnings 5.3 Brakes 5.4 Controls 5.5.4 Access to engine and other compartments 5.7 Operator position 5.7.4 Guards for wheels 5.7.6 Protection against crushing, shearing and trapping 5.7.7 Operator restraint 5.9.1 Overhead guard 5.10.1 Visibility 7.2.2 Operation of the truck and/or attachment(s) 7.3.4.5 Warnings
4.1.3	Cutting or severing hazard	5.1.4 Edges or angles 5.5.4 Access to engine and other compartments 5.7.6 Protection against crushing, shearing and trapping 7.2.5 Service and maintenance of truck and/or attachment(s)
4.1.4	Entanglement hazard	5.5.4 Access to engine and other compartments
4.1.5	Drawing-in or trapping hazard	5.5.4 Access to engine and other compartments 5.7.4 Guards for wheels 5.7.6 Protection against crushing, shearing

iTeh STANDARD PREVIEW  
(standards.iteh.ai)  
ISO/DIS 3691-2  
<https://standards.iteh.ai/catalog/standards/sist/2c72e780-851a-4ec4-9aea-2c9d340d1c2d/iso-dis-3691-2-2>

			and trapping points
		5.11.1	Operator's cab
4.1.6	Impact hazard		
	- from mechanical failure	5.6.1	Chains
		5.6.2	Hydraulic lifting system
		5.6.4	Fork arms
		6	Verification of requirements and safety requirements
		7.2.2	Operation of the truck and/or attachment(s)
		7.2.5	Service and maintenance of truck and/or attachment(s)
	- from unstable loads	5.6.2	Hydraulic lifting system
		5.6.4	Fork arms
		5.6.6	Fork carriers
		5.6.7	Load handling attachments
		5.6.8	Load retention device
		5.9.1	Overhead guard
	- from road debris	5.7.4	Guards for wheels
	- from lifting or transporting a truck	5.11.2	Provisions for transport of the truck and removable attachments
4.1.7	Stabbing or puncture hazard	5.1.4	Edges or angles
		7.2.5	Service and maintenance of the truck and/or attachment(s)
4.1.9	High pressure fluid ejection or ejection hazard	5.1.5	Stored energy components
		5.6.3.1	Hydraulic circuit
		5.6.3.2	Pressure control
		7.2.2	Operation of the truck and/or attachment(s)
4.3	Thermal hazards		
4.3.1	Burns, scalds and other injuries by a possible contact of persons with an extreme high or low temperature, by flames or explosions and also by the radiation of heat sources	5.5.1	Exhaust system
		5.7.5	Protection from burning
		5.11.1.2	Fire resistance
4.3.2	Damage to health by hot or cold working environment	5.11.1	Operator's cab
4.4	Hazards generated by noise		
4.4.1	Hearing loss (deafness), other physiological disorders	7.2.1	Concerning the truck/attachment
		7.2.2	Operation of the truck and/or attachment(s)
4.4.2	Interference with speech communication, acoustic signals, etc.	7.2.1	Concerning the truck/attachment
		7.2.2	Operation of the truck and/or attachment(s)

iTeh STANDARD PREVIEW  
(standards.iteh.ai)

ISO/DIS 3691-2:2005

<https://standards.iteh.ai/catalog/standards/sist/2c72e780-851a-4ec4-9aea-7c9d340d1c2d/iso-dis-3691-2-2>