**Industrial automation systems and
integration — Physical device contro —
Data model for computerized numerical
controllers —**

Part 121:

Tools for turning machines

iTeh STANDARD PREVIEW

(standards) iTeh

*Systemes d'automatisation industrielle et integration — Commande des
dispositifs physiques — Modele de donnees pour les controleurs
numeriques informatises —*

ISO 14649-121:2005
Partie 121: Outils pour le tournage

<https://standards.iteh.ai/catalog/standards/sist/bc91bb3a-8a32-4cd4-b51d-8d06b17a60e7/iso-14649-121-2005>



PDF disclaimer

This PDF file may contain embedded typefaces. In accordance with Adobe's licensing policy, this file may be printed or viewed but shall not be edited unless the typefaces which are embedded are licensed to and installed on the computer performing the editing. In downloading this file, parties accept therein the responsibility of not infringing Adobe's licensing policy. The ISO Central Secretariat accepts no liability in this area.

Adobe is a trademark of Adobe Systems Incorporated.

Details of the software products used to create this PDF file can be found in the General Info relative to the file; the PDF-creation parameters were optimized for printing. Every care has been taken to ensure that the file is suitable for use by ISO member bodies. In the unlikely event that a problem relating to it is found, please inform the Central Secretariat at the address given below.

iTeh STANDARD PREVIEW
(standards.iteh.ai)

[ISO 14649-121:2005](https://standards.iteh.ai/catalog/standards/sist/bc91bb3a-8a32-4cd4-b51d-8d06b17a60e7/iso-14649-121-2005)

<https://standards.iteh.ai/catalog/standards/sist/bc91bb3a-8a32-4cd4-b51d-8d06b17a60e7/iso-14649-121-2005>

© ISO 2005

All rights reserved. Unless otherwise specified, no part of this publication may be reproduced or utilized in any form or by any means, electronic or mechanical, including photocopying and microfilm, without permission in writing from either ISO at the address below or ISO's member body in the country of the requester.

ISO copyright office
Case postale 56 • CH-1211 Geneva 20
Tel. + 41 22 749 01 11
Fax + 41 22 749 09 47
E-mail copyright@iso.org
Web www.iso.org

Published in Switzerland

Contents

Foreword.....	iv
Introduction.....	v
1 Scope	1
2 Normative references	2
3 Terms and definitions	2
4 Tools for turning machines	3
4.1 Header and references	3
4.2 Turning machine cutting tool	5
4.2.1 Cutting edge properties	6
4.2.2 Hand of tool type	9
4.3 Catalogue of turning tool	9
4.3.1 General turning tool	9
4.3.2 Turning threading tool	10
4.3.3 Grooving tool	11
4.3.4 Knurling tool	12
4.3.5 User defined turning tool	13
Annex A: (normative) EXPRESS expanded listing.....	14
Annex B: (informative) EXPRESS-G diagram.....	17
Index	21

Foreword

ISO (the International Organization for Standardization) is a worldwide federation of national standards bodies (ISO member bodies). The work of preparing International Standards is normally carried out through ISO technical committees. Each member body interested in a subject for which a technical committee has been established has the right to be represented on that committee. International organizations, governmental and non-governmental, in liaison with ISO, also take part in the work. ISO collaborates closely with the International Electrotechnical Commission (IEC) on all matters of electrotechnical standardization.

International Standards are drafted in accordance with the rules given in the ISO/IEC Directives, Part 2.

Attention is drawn to the possibility that some of the elements of this part of ISO 14649 may be the subject of patent rights. ISO shall not be held responsible for identifying any or all such patent rights.

International Standard ISO 14649-121 was prepared by Technical Committee ISO/TC 184, *Industrial automation systems and integration*, Subcommittee SC 1, *Physical device control*.

ISO 14649 consists of the following parts, under the general title *Industrial automation systems and integration — Physical device control — Data model for computerized numerical controllers*:

NOTE Phase numbers below refer to the planned release phases of ISO 14649 which are described in Annex D of ISO 14649-1:2002.

- Part 1: Overview and fundamental principles (Phase 1)
- Part 10: General process data (Phase 1) [ISO 14649-121:2005](https://standards.iteh.ai/catalog/standards/sist/bc91bb3a-8a32-4cd4-b51d-8d00b17a60e7/iso-14649-121-2005)
- Part 11: Process data for milling (Phase 1) <https://standards.iteh.ai/catalog/standards/sist/bc91bb3a-8a32-4cd4-b51d-8d00b17a60e7/iso-14649-121-2005>
- Part 12: Process data for turning (Phase 2)
- Part 111: Tools for milling machines (Phase 1)
- Part 121: Tools for turning machines (Phase 2)

Gaps in the numbering were left to allow further additions. ISO 14649-10 is the ISO 10303 Application Reference Model (ARM) for process-independent data. ISO 10303 ARMs for specific technologies are added after part 10.

Introduction

Modern manufacturing enterprises are built from facilities spread around the globe, which contain equipment from hundreds of different manufacturers. Immense volumes of product information must be transferred between the various facilities and machines. Today's digital communications standards have solved the problem of reliably transferring information across global networks. For mechanical parts, the description of product data has been standardized by ISO 10303. This leads to the possibility of using standard data throughout the entire process chain in the manufacturing enterprise. Impediments to realizing this principle are the data formats used at the machine level. Most computer numerical control (CNC) machines are programmed in the ISO 6983 "G and M code" language. Programs are typically generated by computer-aided manufacturing (CAM) systems that use computer-aided design (CAD) information. However, ISO 6983 limits program portability for three reasons. First, the language focuses on programming the tool center path with respect to machine axes, rather than the machining process with respect to the part. Second, the standard defines the syntax of program statements, but in most cases leaves the semantics ambiguous. Third, vendors usually supplement the language with extensions that are not covered in the limited scope of ISO 6983.

ISO 14649 is a new model of data transfer between CAD/CAM systems and CNC machines, which replaces ISO 6983. It remedies the shortcomings of ISO 6983 by specifying machining processes rather than machine tool motion, using the object-oriented concept of Workingsteps. Workingsteps correspond to high-level machining features and associated process parameters. CNCs are responsible for translating Workingsteps to axis motion and tool operation. A major benefit of ISO 14649 is its use of existing data models from ISO 10303. As ISO 14649 provides a comprehensive model of the manufacturing process, it can also be used as the basis for a bi- and multi-directional data exchange between all other information technology systems.

ISO 14649 represents an object oriented, information and context preserving approach for NC-programming that supersedes data reduction to simple switching instructions or linear and circular movements. As it is object- and feature oriented and describes the machining operations executed on the workpiece, and not machine dependent axis motions, it will be running on different machine tools or controllers. This compatibility will spare all data adaptations by postprocessors, if the new data model is correctly implemented on the NC controllers. If old NC programs in ISO 6983 are to be used on such controllers, the corresponding interpreters shall be able to process the different NC program types in parallel.

ISO TC 184/SC 1/WG 7 envisions a gradual evolution from ISO 6983 programming to portable feature-based programming. Early adopters of ISO 14649 will certainly support data input of legacy "G and M codes" manually or through programs, just as modern controllers support both command-line interfaces and graphical user interfaces. This will likely be made easier as open-architecture controllers become more prevalent. Therefore, ISO 14649 does not include legacy program statements, which would otherwise dilute the effectiveness of the standard.

iTeh STANDARD PREVIEW
(standards.iteh.ai)

ISO 14649-121:2005

<https://standards.iteh.ai/catalog/standards/sist/bc91bb3a-8a32-4cd4-b51d-8d06b17a60e7/iso-14649-121-2005>

Industrial automation systems and integration — Physical device control — Data model for computerized numerical controllers —

Part 121: Tools for turning machines

1 Scope

This part of ISO 14649 specifies the data elements describing cutting tool data for turning machine tools and machining centres. They work together with ISO 14649-12, the process data for turning machine tools and machining centres. These data elements can be used as criteria to select one of several operations; they do not describe a complete information of a particular tool. Thus, leaving out optional attributes gives the controller more freedom to select from a larger set of tools.

Note 1 The NC is assumed to have access to complete description of specific tools in a database. The *turning_machine_tool_schema* defined in this part of ISO 14649 serves as a basic tool schema including the information required by the CNC to select a tool from the machine tool's tool turret.

Note 2 In ISO 6983, the tool is defined by its identifier (e.g. T8). No further information concerning the tool type or geometry is given. This information is part of the tool set-up sheet, which is supplied with the NC-program to the machine. The tool set-up sheet gives the relationship between the tool location (e.g. the slot 8 of the tool magazine) and the type of tool (e.g. "drill 4 mm").

This part of ISO 14649 includes the information which is contained in the tool set-up sheet:

- tool identifier;
- tool type;
- tool geometry;
- application dependent expected tool life.

The *turning_machine_tool_schema* does not include information which is part of the tool database. The tool database is related to the machine tool and the tool itself but independent of the NC program. The following data types are out of scope of this part of ISO 14649:

- normative tool life;
- tool location in the tool changer;
- adaptive items also know as tool holders or tool clamping devices;
- tools for other technologies such as milling, grinding, EDM.

Note 3 It is important to understand that all length measure types used in this part of ISO 14649 are not toleranced length measure types because they are used to describe the tools **required** for the manufacturing of a workpiece, not the actual dimensions of the tools available at the machine. A real tool must be selected by the tool management based on the actual tool dimensions and the tolerances of features.

Note 4 Tools in this part of the standard shall describe a tool at whole. No individual components (tool bodies, inserts, or clamping units) are described.

Note 5 Tools for other technologies will be described in further parts of ISO 14649.

2 Normative references

The following referenced documents are indispensable for the application of this document. For dated references, only the edition cited applies. For undated references, the latest edition of the referenced document (including any amendments) applies.

ISO 3002-1:1993, *Basic quantities in cutting and grinding — Part 1: Geometry of the active part of cutting tools — General terms, reference systems, tool and working angles, chip breakers*

ISO 5610:1998, *Single-point tool holders for turning and copying, for indexable inserts — Dimensions*

ISO 10303-11:2004, *Industrial automation systems and integration — Product data representation and exchange — Part 11: Description methods: The EXPRESS language reference manual*

ISO 10303-41:2000, *Industrial automation systems and integration — Product data representation and exchange — Part 41: Integrated generic resource: Fundamentals of product description and support*

ISO 10303-42:2003, *Industrial automation systems and integration — Product data representation and exchange — Part 42: Integrated generic resource: Geometric and topological representation*

ISO 14649-10:2003, *Industrial automation systems and integration — Physical device control — Data model for computerized numerical controllers — Part 10: General process data*

ISO 14649-12:—¹⁾, *Industrial automation systems and integration — Physical device control — Data model for computerized numerical controllers — Part 12: Process data for turning*

ISO 14649-111:—¹⁾, *Industrial automation systems and integration — Physical device control — Data model for computerized numerical controllers — Part 111: Tools for milling machines*

3 Terms and definitions

For the purposes of this document, the terms and definitions given in ISO 14649-10, ISO 14649-12 and the following apply.

3.1 Cutting reference point

The cutting reference point is a theoretical point of the tool from which the major functional dimensions are taken. For the calculation of this point the following cases apply:

Case 1: The tool cutting edge angle is less or equal 90°. The point is the intersection of the tool cutting edge plane, the tool feed plane, and the tool rake plane.

1) To be published.

Case 2: The tool cutting edge is greater than 90°. The point is the intersection of the tool feed plane, a plane perpendicular to tool feed plane and tangential to the cutting corner, and the tool rake plane.

Case 3: ISO tool styles D and V with only axial rake. The point is the intersection of: a plane perpendicular to the primary feed direction and tangential to the cutting edge (tangential point), a plane parallel to the feed direction through the tangential point, and the tool rake plane. The theoretical sharp corner of the insert and the cutting reference point are on the plane that is perpendicular to the tool feed plane.

Case 4: Round inserts

a) One feed direction parallel to the tool axis. The point is the intersection of a plane perpendicular to the primary feed direction and tangential to the cutting edge (tangential point), a plane parallel to the feed direction through the tangential point, and the tool rake plane.

b) Two feed directions, one parallel to the tool axis and one perpendicular to the tool axis with two cutting reference points. Each point is the intersection of a plane perpendicular to its feed direction and tangential to the cutting edge (tangential point), a plane parallel to the feed direction through the tangential point, and the tool rake plane.

3.2 Tool reference point

The tool reference point is the origin point of the co-ordinate axis system. It is a right-handed rectangular Cartesian system in three dimensional space with three principal axes labelled X, Y, and Z.

3.2.1 Prismatic tool item position

The base of the tool item shall be coplanar with the XY-plane. The normal for the base of the tool shall be in the -Z direction. The rear backing surface shall be coplanar with the XZ-plane. The normal for the rear backing surface shall be in the +Y direction. The end of the tool shall be coplanar with the YZ-plane. The normal for the end of the tool shall be in the +X direction. The rake face of the primary cutting item shall be completely visible in the -X/-Y quadrant.

3.2.2 Round tool item position

The axis of the tool item shall be colinear with the X-axis. The vector of the shank that points in the -X direction shall also point towards the workpiece side. The cutting height shall be measured from XY-plane. The drive slots or clamping flats, if present, shall be parallel with the XY-plane. The contact surface of the coupling, the gauge plane or the end of the cylindrical shank shall be coplanar with the YZ-plane. The rake face of the primary cutting item shall be visible in the -X/-Y quadrant.

Left hand items are as defined for right hand items but mirrored through the XZ-plane.

4 Tools for turning machines

4.1 Header and references

The following gives the header for this schema and the list of types and entities which are referenced within this schema.

```
SCHEMA turning_machine_tool_schema;
(*
  Version : 11
```

Date : 04.01.2005
 Author : ISO TC184/SC1/WG7
 Contact : Suk-Hwan Suh (shs@postech.ac.kr) or
 Heusinger (stefan.heusinger@isw.uni-stuttgart.de)

```

*)
(* ***** *)
(* Types from machining_schema ISO 14649-10 *)
(* ***** *)
REFERENCE FROM measure_schema (*ISO10303-41e2*)
  (length_measure,
   plane_angle_measure);

REFERENCE FROM geometry_schema (*ISO10303-42e3*)
  (direction);

REFERENCE FROM machining_schema (
  label,
  machining_tool,
  material,
  technology,
  time_measure);

USE FROM milling_machine_tool_schema;
  
```

iTeh STANDARD PREVIEW
(standards.iteh.ai)

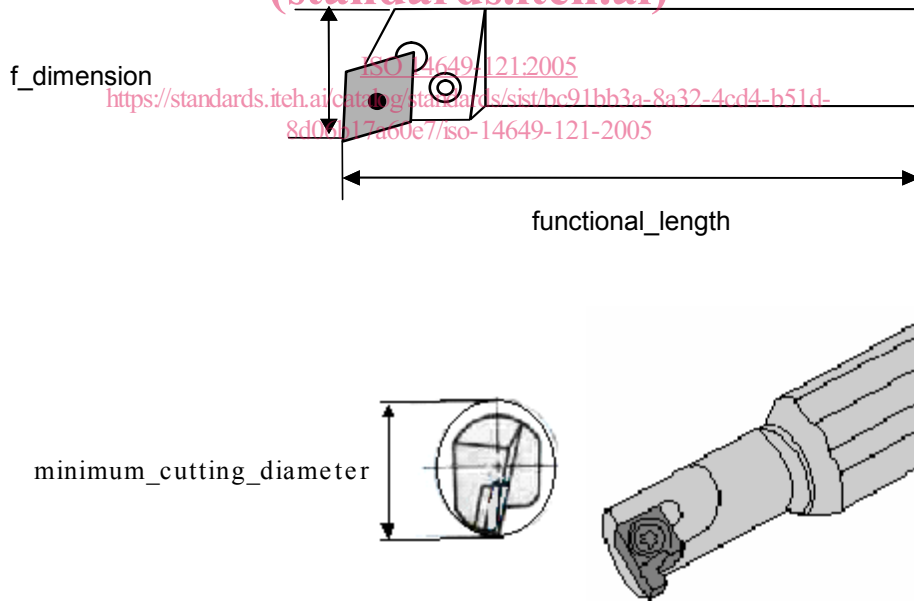

Figure 1 : Turning machine tool.

f = f_dimenstion
 lf = functional_length

4.2 Turning machine cutting tool

Entity to describe the technology specific information needed for description of a cutting tool for milling Machine tools (e.g. milling cutter, reamer, drill, tap, rotating boring tools). It is a subtype of entity *machining_tool* defined in ISO 14649-10.

This entity describes the technology specific information needed for description of cutting tool for turning machine tools. It is a subtype of entity *machining_tool* defined in 4.6.2.3.4 of ISO 14649-10:2004. As illustrated in Figure 1, *overall_assembly_length* means the total length of holder including any portion in front of the cutting point, and *overall_assembly_width* means the total width of holder including any portion in front of the cutting point. The definitions are valid for other types of turning machine tools, such as shown in Figure 2 referenced from ISO 5610.

Drilling type tools and boring type tools (such as drill, reamer and boring tool) are also used in turning operation. Since they are defined in ISO 14649-111 (as subtypes of *milling_machine_tool_body*), they are not defined in this part of ISO 14649. However users can use them by referencing ISO 14649-111.

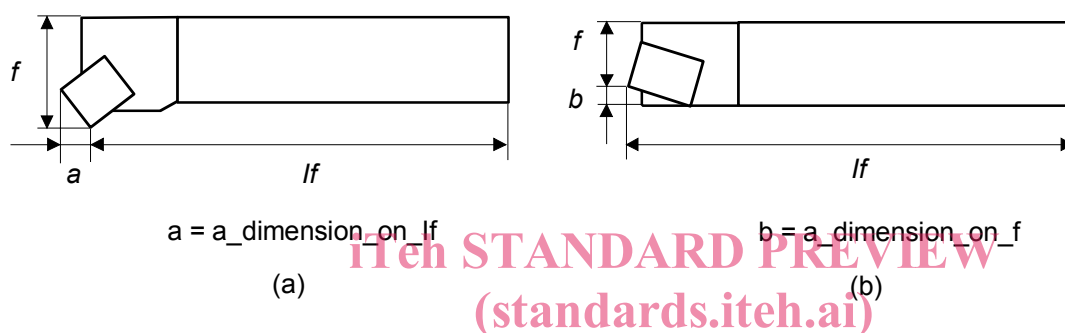

Figure 2: Additional dimensions for turning cutting tools.

[ISO 14649-121:2005](https://standards.iteh.ai/catalog/standards/sist/bc91bb3a-8a32-4cd4-b51d-8d06b17a60e7/iso-14649-121-2005)

<https://standards.iteh.ai/catalog/standards/sist/bc91bb3a-8a32-4cd4-b51d-8d06b17a60e7/iso-14649-121-2005>

```

ENTITY turning_machine_cutting_tool
  SUBTYPE OF (machining_tool);
  functional_length      : length_measure;
  f_dimension            : length_measure;
  minimum_cutting_diameter : OPTIONAL length_measure;
  a_dimension_on_f      : OPTIONAL length_measure;
  a_dimension_on_lf     : OPTIONAL length_measure;
  cutting_edge           : cutting_edge_properties;
  hand_of_tool           : OPTIONAL hand_of_tool_type;
END_ENTITY;

```

- functional_length:** Distance from the gauge plane or from the end of the shank. If a gauge plane does not exist, it is the distance to the cutting reference point determined by the main function of the tool. The short name of this attribute is “lf”.
- f_dimension:** The distance between the cutting reference point and the rear backing surface of a turning tool or the axis of a boring bar.
- minimum_cutting_diameter:** The minimum diameter that can be cut without interference between the workpiece and any part of the cutting tool. This may be used for internal machining; where the hole diameter of the workpiece should be larger than this value.
- a_dimension_on_f:** Dimension from the cutting reference point in the direction of the f dimension to the plane perpendicular to the feed direction and tangential to the secondary corner of the main cutting edge.