



**SLOVENSKI STANDARD**  
**SIST EN 415-6:2013**

**01-junij-2013**

**Nadomešča:**

**SIST EN 415-6:2007+A1:2010**

---

**Pakirne naprave - Varnost pakirnih naprav - 6. del: Stroji za ovijanje palet**

Safety of packaging machines - Part 6: Pallet wrapping machines

Sicherheit von Verpackungsmaschinen - Teil 6: Paletteneinschlagmaschinen

Sécurité des machines d'emballage - Partie 6 : Machines d'emballage de palettes  
**iTeh STANDARD PREVIEW**  
**(standards.iteh.ai)**

**Ta slovenski standard je istoveten z: ~~SIST EN 415-6:2013~~ EN 415-6:2013**

<https://standards.iteh.ai/catalog/standards/sist/fl ddcca2-e598-497d-bb3c-ba50bb34601d/sist-en-415-6-2013>

**ICS:**

55.200

Pakirni stroji

Packaging machinery

**SIST EN 415-6:2013**

**en,fr,de**

**iTeh STANDARD PREVIEW**  
**(standards.iteh.ai)**

[SIST EN 415-6:2013](#)

<https://standards.iteh.ai/catalog/standards/sist/f1ddcca2-e598-497d-bb3c-ba50bb34601d/sist-en-415-6-2013>

EUROPEAN STANDARD

**EN 415-6**

NORME EUROPÉENNE

EUROPÄISCHE NORM

May 2013

ICS 55.200

Supersedes EN 415-6:2006+A1:2009

English Version

**Safety of packaging machines - Part 6: Pallet wrapping machines**

Sécurité des machines d'emballage - Partie 6 : Machines d'emballage de palettes

Sicherheit von Verpackungsmaschinen - Teil 6: Paletteneinschlagmaschinen

This European Standard was approved by CEN on 28 March 2013.

CEN members are bound to comply with the CEN/CENELEC Internal Regulations which stipulate the conditions for giving this European Standard the status of a national standard without any alteration. Up-to-date lists and bibliographical references concerning such national standards may be obtained on application to the CEN-CENELEC Management Centre or to any CEN member.

This European Standard exists in three official versions (English, French, German). A version in any other language made by translation under the responsibility of a CEN member into its own language and notified to the CEN-CENELEC Management Centre has the same status as the official versions.

CEN members are the national standards bodies of Austria, Belgium, Bulgaria, Croatia, Cyprus, Czech Republic, Denmark, Estonia, Finland, Former Yugoslav Republic of Macedonia, France, Germany, Greece, Hungary, Iceland, Ireland, Italy, Latvia, Lithuania, Luxembourg, Malta, Netherlands, Norway, Poland, Portugal, Romania, Slovakia, Slovenia, Spain, Sweden, Switzerland, Turkey and United Kingdom.

**SIST EN 415-6:2013**

<https://standards.iteh.ai/catalog/standards/sist/flddcca2-e598-497d-bb3c-ba50bb34601d/sist-en-415-6-2013>



EUROPEAN COMMITTEE FOR STANDARDIZATION  
COMITÉ EUROPÉEN DE NORMALISATION  
EUROPÄISCHES KOMITEE FÜR NORMUNG

**Management Centre: Avenue Marnix 17, B-1000 Brussels**

## Contents

Page

Foreword.....	5
Introduction .....	6
<b>1 Scope.....</b>	<b>7</b>
<b>2 Normative references.....</b>	<b>8</b>
<b>3 Terms and definitions .....</b>	<b>10</b>
3.1 Definition of terms.....	10
3.2 Description of pallet wrapping machines .....	11
<b>4 List of hazards on pallet wrapping machines .....</b>	<b>25</b>
4.1 General .....	25
4.2 General pallet wrapping machine hazards.....	26
4.3 Specific hazards on pallet wrapping machines excluding shrinking systems and auxiliary machines .....	30
4.4 Specific hazards on pallet shrinking systems .....	34
4.5 Auxiliary machines.....	36
<b>5 Safety requirements and measures for pallet wrapping machines.....</b>	<b>37</b>
5.1 General .....	37
5.2 General requirements for pallet wrapping machines .....	37
5.3 Safety requirements for pallet wrapping machines.....	51
5.4 Safety requirements for shrinking systems.....	56
5.5 Auxiliary machines.....	61
<b>6 Verification of safety requirements and measures.....</b>	<b>61</b>
6.1 General .....	61
6.2 Visual inspections with the machine stopped .....	62
6.3 Measurements with the machine stopped .....	62
6.4 Visual inspections with the machine running.....	62
6.5 Measurements with the machine running.....	63
6.6 Verification procedures .....	63
<b>7 Information for use.....</b>	<b>65</b>
7.1 Marking .....	65
7.2 Signals and warning signs .....	66
7.3 Instruction handbook.....	66
<b>Annex A (normative) Noise test code for pallet wrapping machines - grade of accuracy 2 and 3.....</b>	<b>68</b>
<b>Annex B (normative) Methods of safeguarding large apertures.....</b>	<b>69</b>
B.1 Interlocked guards with guard locking.....	69
B.2 Fixed and interlocked guards with ESPE.....	69
B.3 Positioning of ESPE.....	72
<b>Annex C (normative) ESPE-Muting .....</b>	<b>74</b>
<b>Annex D (informative) List of possibly helpful standards for gas equipment.....</b>	<b>76</b>
<b>Annex E (informative) Significant technical changes between this European Standard and the previous edition EN 415-6:2006+A1:2009.....</b>	<b>77</b>
<b>Annex ZA (informative) Relationship between this European Standard and the Essential Requirements of EU Directive 2006/42/EC .....</b>	<b>78</b>
<b>Bibliography.....</b>	<b>79</b>

## Figures

Figure 1 — Principle of rotary table machine .....	12
Figure 2 — Manual rotary table machine .....	12
Figure 3 — Automatic rotary table machine .....	12
Figure 4 — Semiautomatic rotary arm machine .....	13
Figure 5 — Fully automatic rotary arm machine .....	14
Figure 6 — Ring machine – Principle of operation .....	15
Figure 7 — Semi automatic self driving pallet stretch wrapping machine .....	15
Figure 8 — Mobile pallet stretch wrapping machine .....	16
Figure 9 — Curtain stretching machine – Principle of operation .....	16
Figure 10 — Hood stretching machine .....	17
Figure 11 — Spiral pallet wrapping machine .....	19
Figure 12 — Vertical hood application machine .....	20
Figure 13 — Parachute hood application machine .....	20
Figure 14 — Shrinking frame .....	21
Figure 15 — Chamber shrinking oven with electric heating device .....	22
Figure 16 — Continuous shrinking oven using thermal combustion heating .....	23
Figure 17 — Shrinking column using thermal combustion .....	24
Figure 18 — Product centralizing machine .....	25
Figure 19 — Semiautomatic or manual rotary table machines: crushing, shearing and drawing-in hazard location .....	31
Figure 20 — Warning sign "Caution, hot surface" .....	44
Figure 21 — Semiautomatic or manual rotary table machines with apertures in the table .....	52
Figure 22 — Methods for safeguarding of film rollers .....	53
Figure B.1 — Interlocked guards with guard locking .....	69
Figure B.2 — Example of a combination of fixed and interlocked guards and ESPE .....	70
Figure B.3 — Dynamic cell positioning .....	72
Figure B.4 — Positioning of ESPE .....	73
Figure C.1 — Positioning of muting ESPE .....	75

**EN 415-6:2013 (E)****Tables**

Table 1 —Degree of protection for dusty environments .....	42
Table 2 — Degree of protection for different cleaning methods using water .....	42
Table 3 — Verification procedures for safety requirements identified in 5.2 and 5.3 .....	64
Table 3 ( <i>continued</i> ) .....	65

**iTeh STANDARD PREVIEW**  
**(standards.iteh.ai)**

[SIST EN 415-6:2013](https://standards.iteh.ai/catalog/standards/sist/fl ddcca2-e598-497d-bb3c-ba50bb34601d/sist-en-415-6-2013)

<https://standards.iteh.ai/catalog/standards/sist/fl ddcca2-e598-497d-bb3c-ba50bb34601d/sist-en-415-6-2013>

## Foreword

This document (EN 415-6:2013) has been prepared by Technical Committee CEN/TC 146 "Packaging Machines Safety", the secretariat of which is held by UNI.

This European Standard shall be given the status of a national standard, either by publication of an identical text or by endorsement, at the latest by November 2013, and conflicting national standards shall be withdrawn at the latest by November 2013.

Attention is drawn to the possibility that some of the elements of this document may be the subject of patent rights. CEN [and/or CENELEC] shall not be held responsible for identifying any or all such patent rights.

This document supersedes EN 415-6:2006+A1:2009.

This document has been prepared under a mandate given to CEN by the European Commission and the European Free Trade Association, and supports essential requirements of EU Directive(s).

For relationship with EU Directive(s), see informative Annex ZA, which is an integral part of this document.

Annex E provides details of significant technical changes between this European Standard and the previous edition: EN 415-6:2006+A1:2009.

EN 415 "Safety of packaging machines" consists of the following parts:

- *Part 1: Terminology and classification of packaging machines and associated equipment*
- *Part 2: Pre-formed rigid container packaging machines*
- *Part 3: Form, fill and seal machines*
- *Part 4: Palletisers and depalletisers*
- *Part 5: Wrapping machines*
- *Part 6: Pallet wrapping machines*
- *Part 7: Group and secondary packaging machines*
- *Part 8: Strapping machines*
- *Part 9: Noise measurement methods for packaging machines, packaging lines and associated equipment, grade of accuracy 2 and 3*

According to the CEN-CENELEC Internal Regulations, the national standards organizations of the following countries are bound to implement this European Standard: Austria, Belgium, Bulgaria, Croatia, Cyprus, Czech Republic, Denmark, Estonia, Finland, Former Yugoslav Republic of Macedonia, France, Germany, Greece, Hungary, Iceland, Ireland, Italy, Latvia, Lithuania, Luxembourg, Malta, Netherlands, Norway, Poland, Portugal, Romania, Slovakia, Slovenia, Spain, Sweden, Switzerland, Turkey and the United Kingdom.

## Introduction

Pallet wrapping machines are used extensively in Europe, in an increasingly wide range of industries. They contain several significant hazards and have the potential to cause serious injury.

Pallet wrapping machines fulfil the following major tasks:

- securing of palletised or unpalletised loads to prevent them collapsing and displacing during transport, handling, storage;
- pooling of loads and parts to form loads suitable for transport;
- protection against external influences;
- conditional protection against theft.

This document is a type C standard as defined in the Introduction of EN ISO 12100:2010.

The machinery concerned and the extent to which hazards, hazardous situations and events are covered are indicated in the scope of this standard.

When provisions of this type C standard are different from those, which are stated in type A or B standards, the provisions of this type C standard take precedence.

**iTeh STANDARD PREVIEW**  
(standards.iteh.ai)  
<https://standards.iteh.ai/catalog/standards/sist/fl ddcca2-e598-497d-bb3c-ba50bb34601d/sist-en-415-6-2013>



## 1 Scope

This European Standard applies to the following groups of machines:

- pallet banding machines;
- stretch film pallet wrapping machines;
- stretch film hood application machines;
- mobile stretch film wrapping machines;
- semi automatic self driving stretch film wrapping machines;
- shrink film pallet wrapping machines;
- shrink film hood application machines;
- film removing machines;
- shrinking systems;
- sleeve wrapping machines for product greater than 400 mm in one direction;
- product centralising machines.

The individual machines are described in 3.2.

This standard deals with safety requirements for machine design, construction, installation, commissioning, operation, adjustment, maintenance and cleaning of pallet wrapping machines.

The extents to which hazards, hazardous situations and events are covered are indicated in Clause 4.

### Exclusions

This European Standard is not applicable to the following machines:

- machines that were manufactured before the date of publication of this document by CEN;
- pallet strapping machines and destrapping machines. These machines are within the scope of EN 415-8;
- conveying systems that connect packaging machines with each other, but includes conveying systems that are part of the machines.

This standard does not consider the following hazards:

- the use of pallet wrapping machines in potentially explosive atmospheres;
- the health, safety or hygiene hazards associated with the products that may be handled by the machines, but does include general advice on this subject;
- hazards that may be associated with electromagnetic emissions from pallet wrapping machines;
- hazards that may be associated with decommissioning pallet wrapping machines.

**EN 415-6:2013 (E)****2 Normative references**

The following documents, in whole or in part, are normatively referenced in this document and are indispensable for its application. For dated references, only the edition cited applies. For undated references, the latest edition of the referenced document (including any amendments) applies.

EN 203-1:2005+A1:2008 *Gas heated catering equipment — Part 1: General safety rules*

EN 349:1993+A1:2008, *Safety of machinery — Minimum gaps to avoid crushing of parts of the human body*

EN 415-1:2000+A1:2009, *Packaging machines safety — Part 1: Terminology and classification of packaging machines and associated equipment*

EN 415-9:2009, *Safety of packaging machines — Part 9: Noise measurement methods for packaging machines, packaging lines and associated equipment, grade of accuracy 2 and 3*

EN 574:1996+A1:2008, *Safety of machinery — Two-hand control devices — Functional aspects — Principles for design*

EN 614-1, *Safety of machinery — Ergonomic design principles — Part 1: Terminology and general principles*

EN 614-2, *Safety of machinery — Ergonomic design principles — Part 2: Interactions between the design of machinery and work tasks*

EN 619, *Continuous handling equipment and systems — Safety and EMC requirements for equipment for mechanical handling of unit loads*

EN 626-1, *Safety of machinery — Reduction of risks to health from hazardous substances emitted by machinery — Part 1: Principles and specifications for machinery manufacturers*

EN 626-2, *Safety of machinery — Reduction of risk to health from hazardous substances emitted by machinery — Part 2: Methodology leading to verification procedures*

EN 894-1, *Safety of machinery — Ergonomics requirements for the design of displays and control actuators — Part 1: General principles for human interactions with displays and control actuators*

EN 894-2, *Safety of machinery — Ergonomics requirements for the design of displays and control actuators — Part 2: Displays*

EN 894-3, *Safety of machinery — Ergonomics requirements for the design of displays and control actuators — Part 3: Control actuators*

EN 953:1997+A1:2009, *Safety of machinery — Guards — General requirements for the design and construction of fixed and movable guards*

EN 1005-3, *Safety of machinery — Human physical performance — Part 3: Recommended force limits for machinery operation*

EN 1037, *Safety of machinery — Prevention of unexpected start-up*

EN 1088:1995+A2:2008, *Safety of machinery — Interlocking devices associated with guards — Principles for design and selection*

EN 1672-2:2005+A1:2009, *Food processing machinery — Basic concepts — Part 2: Hygiene requirements*

EN 1760-1, *Safety of machinery — Pressure sensitive protective devices — Part 1: General principles for the design and testing of pressure sensitive mats and pressure sensitive floors*

- EN 1760-2, *Safety of machinery — Pressure sensitive protective devices — Part 2: General principles for the design and testing of pressure sensitive edges and pressure sensitive bars*
- EN 13478, *Safety of machinery — Fire prevention and protection*
- EN 60204-1:2006, *Safety of machinery — Electrical equipment of machines — Part 1: General requirements (IEC 60204-1:2005, modified)*
- EN 61310-1:2008, *Safety of machinery — Indication, marking and actuation — Part 1: Requirements for visual, acoustic and tactile signals (IEC 61310-1:2007)*
- EN 61310-3, *Safety of machinery — Indication, marking and actuation — Part 3: Requirements for the location and operation of actuators (IEC 61310-3)*
- EN 61496-1:2004, *Safety of machinery — Electro-sensitive protective equipment — Part 1: General requirements and tests (IEC 61496-1:2004, modified)*
- EN 61496-3, *Safety of machinery — Electro-sensitive protective equipment — Part 3: Particular requirements for Active Opto-electronic Protective Devices responsive to Diffuse Reflection (AOPDDR)*
- EN 61508-1, *Functional safety of electrical/electronic/programmable electronic safety-related systems — Part 1: General requirements (IEC 61508-1)*
- EN 61508-2, *Functional safety of electrical/electronic/programmable electronic safety-related systems — Part 2: Requirements for electrical/electronic/programmable electronic safety-related systems (IEC 61508-2)*
- EN 61508-3, *Functional safety of electrical/electronic/programmable electronic safety-related systems — Part 3: Software requirements*
- EN 62061:2005, *Safety of machinery — Functional safety of safety-related electrical, electronic and programmable electronic control systems (IEC 62061:2005)*
- EN ISO 4413:2010, *Hydraulic fluid power — General rules and safety requirements for systems and their components (ISO 4413:2010)*
- EN ISO 4414:2010, *Pneumatic fluid power — General rules and safety requirements for systems and their components (ISO 4414:2010)*
- EN ISO 12100:2010, *Safety of machinery — General principles for design — Risk assessment and risk reduction (ISO 12100:2010)*
- EN ISO 13732-1 *Ergonomics of the thermal environment – Methods for the assessment of human responses to contact with surfaces – Part 1: Hot surfaces (ISO 13732-1)*
- EN ISO 13849-1:2008, *Safety of machinery — Safety-related parts of control systems — Part 1: General principles for design (ISO 13849-1:2006)*
- EN ISO 13850, *Safety of machinery — Emergency stop — Principles for design (ISO 13850)*
- EN ISO 13855, *Safety of machinery — Positioning of safeguards with respect to the approach speeds of parts of the human body (ISO 13855)*
- EN ISO 13857:2008, *Safety of machinery – Safety distances to prevent hazard zones being reached by upper and lower limbs (ISO 13857:2008)*
- EN ISO 14122-1:2001, *Safety of machinery — Permanent means of access to machinery — Part 1: Choice of fixed means of access between two levels (ISO 14122-1:2001)*

**EN 415-6:2013 (E)**

EN ISO 14122-2, *Safety of machinery — Permanent means of access to machinery — Part 2: Working platforms and walkways (ISO 14122-2)*

EN ISO 14122-3, *Safety of machinery — Permanent means of access to machinery — Part 3: Stairs, stepladders and guard-rails (ISO 14122-3)*

EN ISO 14122-4, *Safety of machinery — Permanent means of access to machinery — Part 4: Fixed ladders (ISO 14122-4)*

ISO 7000, *Graphical symbols for use on equipment — Registered symbols*

**3 Terms and definitions**

For the purposes of this document the terms and definitions given in Clause 3 of EN ISO 12100:2010, and EN 415-1:2000+A1:2009 and the following apply.

**3.1 Definition of terms****3.1.1****product**

article or articles, with or without pallet, that are handled in the pallet wrapping machine

**3.1.2****pack**

assembly of product and packaging materials produced by a pallet wrapping machine

**3.1.3****packaging material**

material used to secure a product, e.g. stretch film [SIST EN 415-6:2013](#)

<https://standards.iteh.ai/catalog/standards/sist/fl ddcca2-e598-497d-bb3c-ba50bb34601d/sist-en-415-6-2013>

**3.1.4****flexible packaging material**

relatively thin paper, plastic film or flexible laminate

**3.1.5****stretch film**

flexible elastic plastic film which can be pulled tightly around a product to form an envelope. It may stick to itself on contact or require heat sealing

**3.1.6****stretch wrapping**

wrapping process in which the stretch film is stretched and wrapped around the product and sealed under tension

**3.1.7****thermoplastic film, shrink film**

plastic film which shrinks when heated

**3.1.8****film reel, packaging material reel**

continuous sheet of paper, plastic film, metal foil or flexible laminate wound on a cylindrical core

**3.1.9****film clamp**

device to hold the film at the product for the first wrap. Also called film fixture

**3.1.10****manual operation**

machine functions or modes where the only power source is directly applied manual effort

**3.1.11****top sheet**

piece of packaging material which is applied to the top of the product e.g. to achieve water and dust protection

**3.2 Description of pallet wrapping machines****3.2.1 General**

Pallet wrapping machines are machines listed in Clause 1 that secure product for transport and other purposes e.g. by applying packaging material or shrinking shrink film. Many of the machines deal with palletised products, therefore they are called, e.g.: pallet shrink wrapping machine, pallet shrink oven (see 3.12.3 of EN 415-1:2000+A1:2009). In many cases, however, machines can function without a pallet or with an alternative form of support for the pack.

**3.2.2 Spiral stretch wrapping machines****3.2.2.1 General**

The stretching method uses film webs that are wound around product according to a given winding pattern (e.g. single or cross bracing). The number of the bottom windings or bottom edge windings or the degree of overlapping of the film webs can be variably adjusted.

Stretch film wrapping machines wind a stretch film spirally around product, thus resulting in an envelope with horizontal and vertical tension forces.

Pallet stretch wrapping machines include:

- Automatic stretch film wrapping machines: The machine is loaded and unloaded automatically by a conveyor. The application of the stretch film, stretching and cutting of the stretch film are done automatically.
- Semiautomatic stretch film wrapping machines: One or more of the following are done manually: loading or unloading of the machine, application or cutting of the stretch film. The wrapping movement is done automatically.
- Manual stretch film wrapping machines: Like semiautomatic stretch film wrapping machines, but additionally the movement of the lifting mechanism is done manually.

The following types of stretch film wrapping machines exist.

**3.2.2.2 Rotary table machine**

Product, which is positioned on a table that rotates, is wrapped. When used, vertically moveable film carriage and pre-stretching device are fitted to a column. The functional principle of a rotary table machine is shown in Figure 1. On manual rotary machine the vertical movement of the film carriage is done by an operator (see Figure 2). An example of a fully automatic rotary table machine is shown in Figure 3.

The principle components are rotating table and film reel.

Optional assemblies: conveyors, film clamp, film knife, film sealing device, hold-down plate, pre-stretching unit on the film reel assembly, top sheet feeder.

## EN 415-6:2013 (E)

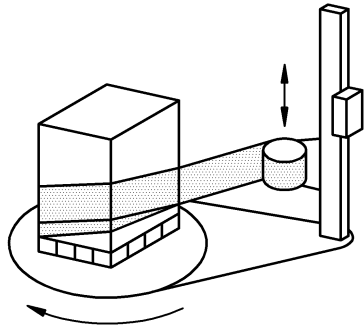

Figure 1 — Principle of rotary table machine

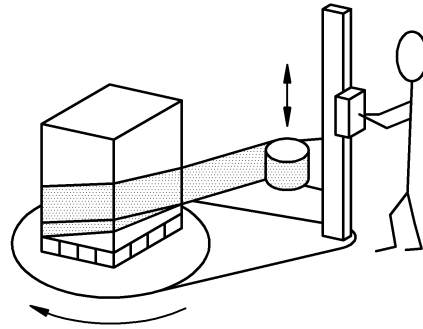
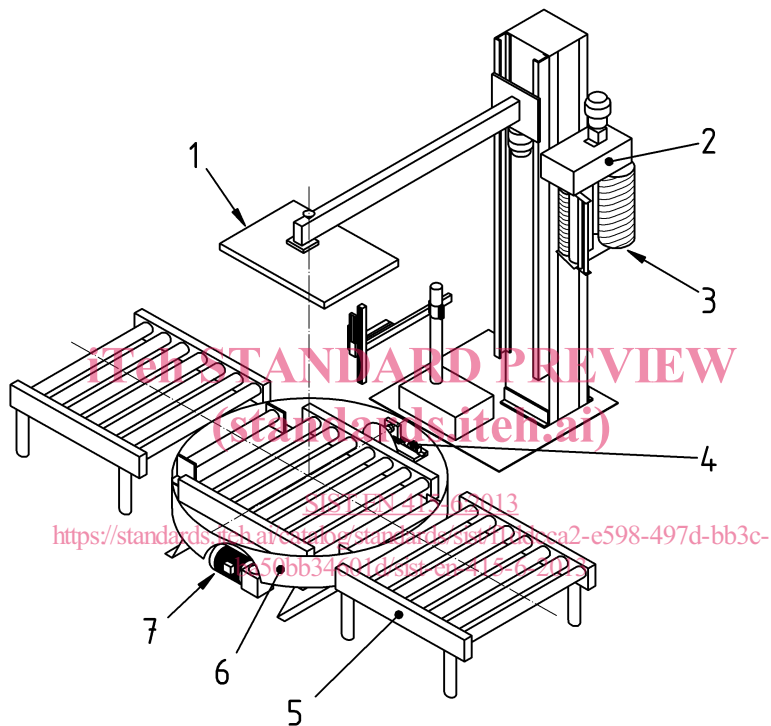

Figure 2 — Manual rotary table machine

**Key**

- 1 hold down plate
- 2 pre-stretching device
- 3 film reel
- 4 film fixture system
- 5 conveyor
- 6 rotary table
- 7 film cutting device

Figure 3 — Automatic rotary table machine

**3.2.2.3 Rotary arm machine**

Machine which wraps product in film or net, from a reel on an arm which rotates around the stationary product (see Figure 4 and Figure 5).

The principle components are: rotating arm, film reel assembly and lifting mechanism which moves the arm up and down.

Optional assemblies: conveyors, film clamp, film knife, film sealing device, hold-down plate, pre-stretching unit on the film reel assembly, top sheet feeder.

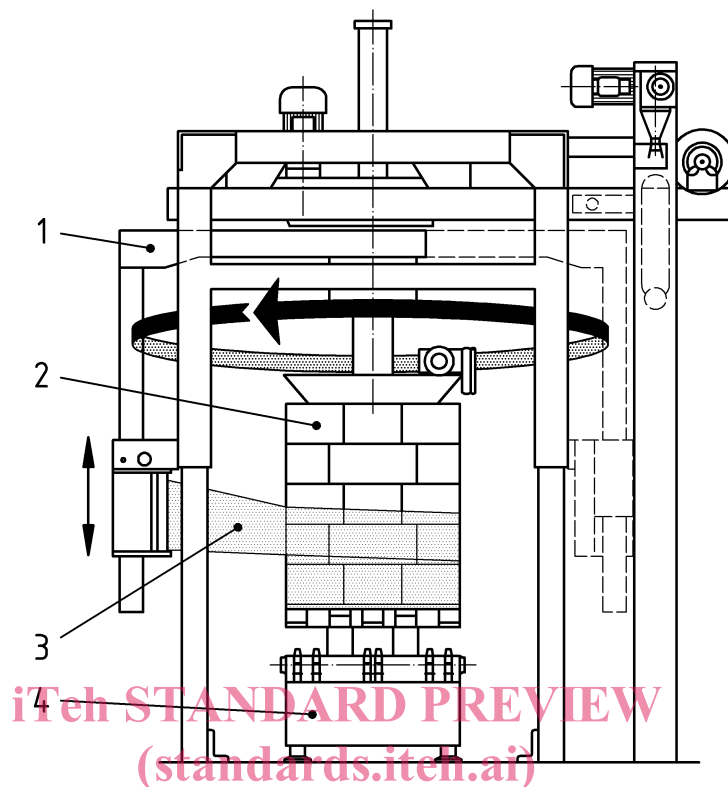

**Key**

- 1 rotary arm
- 2 product
- 3 film
- 4 conveying device

SIST EN 415-6:2013

<https://standards.itech.ai/catalog/standards/sist/fl ddcca2-e598-497d-bb3c-ba50bb34601d/sist-en-415-6-2013>

**Figure 4 — Semiautomatic rotary arm machine**