**Assembly tools for screws and nuts —
Screwdrivers for cross-recessed head
screws —**

**Part 1:
Driver tips**

*Outils de manœuvre pour vis et écrous — Tournevis pour vis à
empreinte cruciforme —*

Partie 1: Extrémités de tournevis

iTeh Standards
(<https://standards.iteh.ai>)
Document Preview

[ISO 8764-1:2004](https://standards.iteh.ai/catalog/standards/iso/f92131f5-8ba9-4289-9ecc-d274d0fe588b/iso-8764-1-2004)

<https://standards.iteh.ai/catalog/standards/iso/f92131f5-8ba9-4289-9ecc-d274d0fe588b/iso-8764-1-2004>



PDF disclaimer

This PDF file may contain embedded typefaces. In accordance with Adobe's licensing policy, this file may be printed or viewed but shall not be edited unless the typefaces which are embedded are licensed to and installed on the computer performing the editing. In downloading this file, parties accept therein the responsibility of not infringing Adobe's licensing policy. The ISO Central Secretariat accepts no liability in this area.

Adobe is a trademark of Adobe Systems Incorporated.

Details of the software products used to create this PDF file can be found in the General Info relative to the file; the PDF-creation parameters were optimized for printing. Every care has been taken to ensure that the file is suitable for use by ISO member bodies. In the unlikely event that a problem relating to it is found, please inform the Central Secretariat at the address given below.

iTeh Standards
(<https://standards.iteh.ai>)
Document Preview

[ISO 8764-1:2004](https://standards.iteh.ai/catalog/standards/iso/f92131f5-8ba9-4289-9ecc-d274d0fe588b/iso-8764-1-2004)

<https://standards.iteh.ai/catalog/standards/iso/f92131f5-8ba9-4289-9ecc-d274d0fe588b/iso-8764-1-2004>

© ISO 2004

All rights reserved. Unless otherwise specified, no part of this publication may be reproduced or utilized in any form or by any means, electronic or mechanical, including photocopying and microfilm, without permission in writing from either ISO at the address below or ISO's member body in the country of the requester.

ISO copyright office
Case postale 56 • CH-1211 Geneva 20
Tel. + 41 22 749 01 11
Fax + 41 22 749 09 47
E-mail copyright@iso.org
Web www.iso.org

Published in Switzerland

Contents

Page

| | |
|---|-----------|
| Foreword | iv |
| 1 Scope | 1 |
| 2 Normative references | 1 |
| 3 Shapes and dimensions | 1 |
| 4 Technical requirements | 5 |
| 5 Inspection of dimensions | 5 |
| 6 Torque test | 9 |
| 7 Designation | 12 |
| Annex A (informative) Explanation of choice of gauge dimensions for form PH tips | 13 |
| Annex B (informative) Guide for inspection gauges for form PZ tips | 14 |

iTeh Standards
 (<https://standards.iteh.ai>)
 Document Preview

[ISO 8764-1:2004](https://standards.iteh.ai/catalog/standards/iso/f92131f5-8ba9-4289-9ecc-d274d0fe588b/iso-8764-1-2004)

<https://standards.iteh.ai/catalog/standards/iso/f92131f5-8ba9-4289-9ecc-d274d0fe588b/iso-8764-1-2004>

Foreword

ISO (the International Organization for Standardization) is a worldwide federation of national standards bodies (ISO member bodies). The work of preparing International Standards is normally carried out through ISO technical committees. Each member body interested in a subject for which a technical committee has been established has the right to be represented on that committee. International organizations, governmental and non-governmental, in liaison with ISO, also take part in the work. ISO collaborates closely with the International Electrotechnical Commission (IEC) on all matters of electrotechnical standardization.

International Standards are drafted in accordance with the rules given in the ISO/IEC Directives, Part 2.

The main task of technical committees is to prepare International Standards. Draft International Standards adopted by the technical committees are circulated to the member bodies for voting. Publication as an International Standard requires approval by at least 75 % of the member bodies casting a vote.

Attention is drawn to the possibility that some of the elements of this document may be the subject of patent rights. ISO shall not be held responsible for identifying any or all such patent rights.

ISO 8764-1 was prepared by Technical Committee ISO/TC 29, *Small tools*, Subcommittee SC 10, *Assembly tools for screws and nuts, pliers and nippers*.

This third edition cancels and replaces the second edition (ISO 8764-1:1999), which has been technically revised as follows:

- a designation has been added;
- in the English version, the term “point” becomes “tip” and “type” becomes “form”;
- in the French version, the term “type” becomes “forme”.

ISO 8764 consists of the following parts, under the general title *Assembly tools for screws and nuts — Screwdrivers for cross-recessed head screws*:

- *Part 1: Driver tips*
- *Part 2: General requirements, lengths of blades and marking of hand-operated screwdrivers*

Assembly tools for screws and nuts — Screwdrivers for cross-recessed head screws —

Part 1: Driver tips

1 Scope

This part of ISO 8764 specifies the shapes and dimensions, technical requirements and torque test methods for the tips of hand drivers and of machine-operated bits for cross-recessed head screws.

It specifies two forms of driver tips:

- form PH for form H recesses;
- form PZ for form Z recesses.

H and Z form recesses are specified in ISO 4757.

General requirements, lengths of blades and marking of hand-operated screwdrivers are given in ISO 8764-2.

2 Normative references

The following referenced documents are indispensable for the application of this document. For dated references, only the edition cited applies. For undated references, the latest edition of the referenced document (including any amendments) applies.

ISO 4757, *Cross recesses for screws*

ISO 8764-2, *Assembly tools for screws and nuts — Screwdrivers for cross-recessed head screws — Part 2: General requirements, lengths of blades and marking of hand-operated screwdrivers*

3 Shapes and dimensions

The shapes and dimensions of the tips shall be in accordance with Figure 1 and Table 1 for form PH, and with Figure 2 and Table 2 for form PZ.

The axis of the tip shall be concentric with the axis of the tool.

When a plated finish is used, the dimensions shall be met after plating.

Dimensions in millimetres

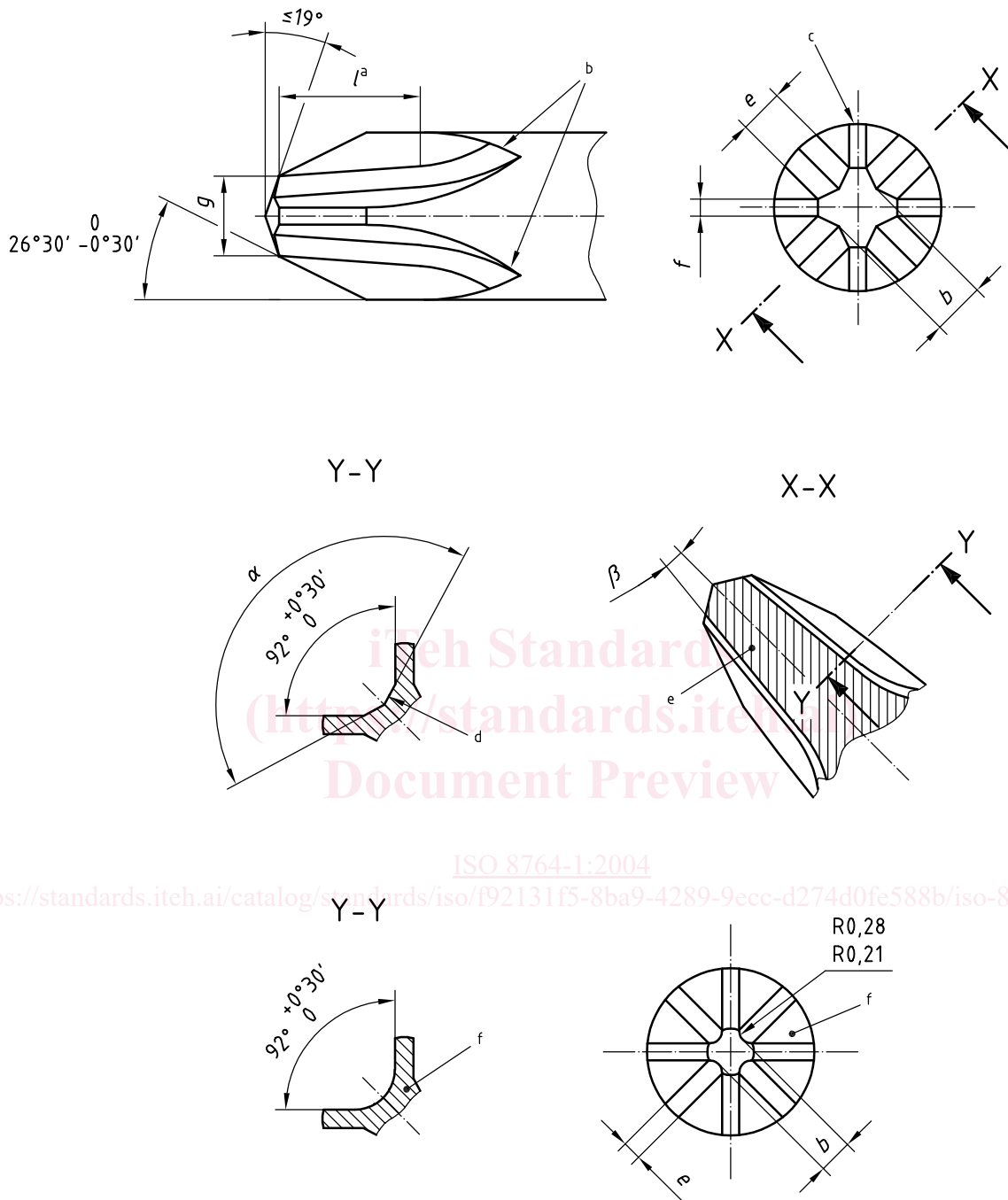

- a Length of straight part.
- b Blending of flutes dependent on method of manufacture.
- c Flutes equally spaced at 90° .
- d For tip No. 0, see detail below (f).
- e Section Y-Y: true flute angle measured at right angles to straight part of length l .
- f Tip No. 0.

Figure 1 — Form PH tips

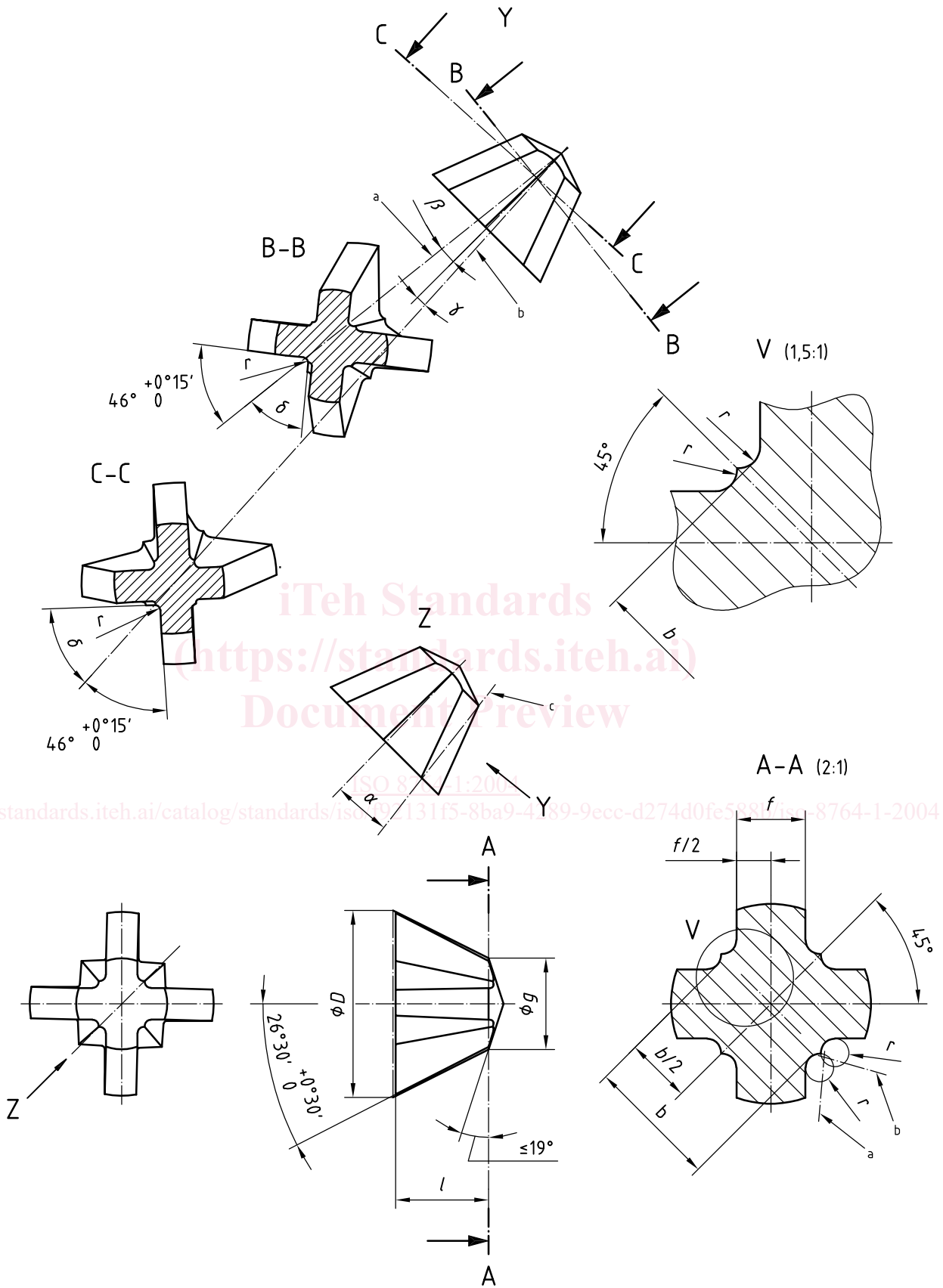

a Axis b.

b Axis g.

c Axes b and g.

Figure 2 — Form PZ tips

Table 1 — Dimensions of form PH tips

| Tip | Nominal blade diameter mm | <i>b</i> mm | <i>e</i> mm | <i>f</i> mm | <i>g</i> mm | <i>l</i> min. mm | α | β |
|-----|------------------------------|----------------|----------------|----------------|----------------|------------------------|--------------|---------|
| 0 | 3 | 0,61 | 0,38 | 0,31 | 0,84 | 2,78 | See Figure 1 | 7° 00' |
| | | 0,56 | 0,29 | 0,26 | 0,79 | | | 6° 30' |
| 1 | 4,5 | 1,03 | 0,54 | 0,53 | 1,30 | 2,78 | 138° 30' | 7° 00' |
| | | 0,98 | 0,49 | 0,48 | 1,25 | | 138° 00' | 6° 30' |
| 2 | 6 | 1,56 | 1,13 | 0,64 | 2,31 | 4,37 | 140° 30' | 5° 45' |
| | | 1,51 | 1,08 | 0,59 | 2,26 | | 140° 00' | 5° 15' |
| 3 | 8 | 2,52 | 2,12 | 0,81 | 3,84 | 6,74 | 146° 30' | 5° 45' |
| | | 2,47 | 2,07 | 0,73 | 3,79 | | 146° 00' | 5° 15' |
| 4 | 10 | 3,60 | 2,76 | 1,12 | 5,11 | 8,34 | 153° 30' | 7° 00' |
| | | 3,55 | 2,71 | 1,04 | 5,06 | | 153° 00' | 6° 30' |

iTeh Standards
(<https://standards.itih.ai>)

Table 2 — Dimensions of form PZ tips

| Tip | Nominal blade diameter mm | <i>b</i> mm | <i>f</i> mm | <i>g</i> mm | <i>l</i> min. mm | <i>r</i> mm | α | β | γ | δ |
|-----|------------------------------|----------------|----------------|----------------|------------------------|----------------|----------|---------|----------|--------------------|
| 0 | 3 | 0,78 | 0,45 | 0,92 | 1,54 | 0,10 | 7° 00' | 8° 15' | 4° 53' | 46° 15' 46° 00' |
| | | 0,70 | 0,42 | 0,89 | | 0,07 | | | | |
| 1 | 4,5 | 1,19 | 0,71 | 1,40 | 2,02 | 0,13 | 6° 30' | 7° 45' | 4° 23' | |
| | | 1,11 | 0,68 | 1,37 | | 0,10 | | | | |
| 2 | 6 | 1,78 | 1,00 | 2,44 | 3,17 | 0,30 | 5° 45' | 6° 50' | 3° 30' | |
| | | 1,70 | 0,95 | 2,39 | | 0,15 | | | | |
| 3 | 8 | 2,65 | 1,38 | 3,96 | 4 | 0,36 | 5° 15' | 6° 20' | 3° 00' | |
| | | 2,55 | 1,33 | 3,91 | | 0,20 | | | | |
| 4 | 10 | 4,02 | 2,10 | 5,18 | 5,4 | 0,51 | 7° 00' | 8° 15' | 4° 53' | |
| | | 3,92 | 2,05 | 5,13 | | 0,36 | | | | 6° 30' |

4 Technical requirements

4.1 Material

Components shall be manufactured from steel which, when suitably heat-treated, satisfies the mechanical requirements and torque tests specified in 4.2 and Clause 6 respectively.

4.2 Heat treatment and hardness

The screwdriver tips shall have a minimum hardness of

- 54 HRC for hand-operated screwdrivers,
- 58 HRC for machine-operated screwdrivers,

for a minimum length of three times the nominal blade diameter measured from the driving end.

The remainder of the tool shall be hardened and tempered to a minimum of 50 HRC.

All hardness measurements shall be taken on ground flats, parallel with the axis and of sufficient area to give an accurate reading.

4.3 Finish

Components shall be free from cracks, blemishes and other deleterious defects.

5 Inspection of dimensions

5.1 General

Conformance with the dimensions as specified in Clause 3 shall be determined either by direct measurement or by the use of suitable inspection gauges as defined in 5.2 and 5.3.

5.2 Inspection gauges for form PH tips

The dimensions of the tips are in accordance with this part of ISO 8764 when they fit properly into the gauge and when the edges of the tips at which the two cones of 53° and 142° meet and lie within step *c* of the gauge (see Figure 3 and Table 3). See Annex A for an explanation of the choice of dimensions.

5.3 Inspection gauges for form PZ tips

See Table 4 and Figure 4.

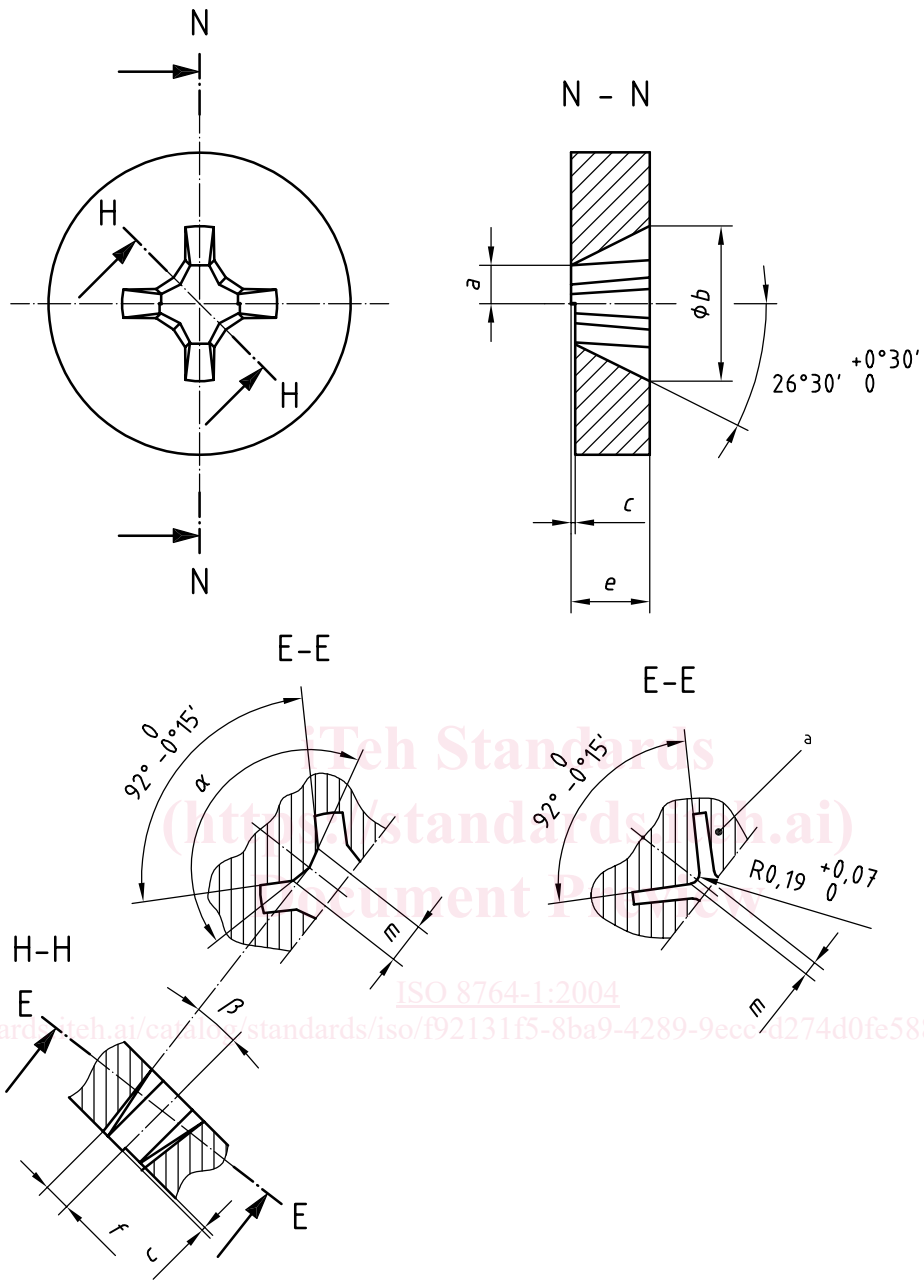

a Size No. 0.

Figure 3 — Inspection gauge for form PH tips