



Designation: D 2098 – 00

## Standard Test Method for Dynamic Water Resistance of Shoe Upper Leather by the Dow Corning Leather Tester<sup>1</sup>

This standard is issued under the fixed designation D 2098; the number immediately following the designation indicates the year of original adoption or, in the case of revision, the year of last revision. A number in parentheses indicates the year of last reapproval. A superscript epsilon ( $\epsilon$ ) indicates an editorial change since the last revision or reapproval.

*This standard has been approved for use by agencies of the Department of Defense.*

### 1. Scope

1.1 This test method covers the determination of the dynamic water resistance of shoe upper leather by means of the Dow Corning Tester. It has been revised to show the state of the art in the equipment used in testing. It is applicable to all types of shoe upper leather. This test method does not apply to wet blue.

1.2 Initial water penetration and water absorption can be measured.

1.3 *This standard does not purport to address all of the safety concerns, if any, associated with its use. It is the responsibility of the user of this standard to establish appropriate safety and health practices and determine the applicability of regulatory limitations prior to use.*

### 2. Referenced Documents

#### 2.1 ASTM Standards:

D 2099 Test Method for Dynamic Water Resistance of Shoe Upper Leather by the Maeser Water Penetration Tester<sup>2</sup>

### 3. Significance and Use

3.1 This test method is intended to estimate the water resistance of shoe upper leather. The flex imparted to the leather is a magnification of the flex given the vamp of the shoe in actual wear.

NOTE 1—There is an indication that this test method *cannot be used interchangeably* for specification purposes with Test Method D 2099.

### 4. Apparatus

4.1 *Balance*, sensitive to 0.01 g.

4.2 *Dow Corning Leather Tester*,<sup>3</sup> as shown in Fig. 1, or its equivalent. The essential features of the machine are as follows:

4.2.1 A specimen holder made of two vertical clamps. Each clamp shall have two stainless steel arms (7.5 by 0.5 by 0.5 in. (190.5 by 12.7 by 12.7 mm)), one arm fixed, the other moveable. One clamp shall be mounted on a horizontal reciprocating shaft, that is, attached by a connecting link to a motor driven eccentric, which turns at 60 r/min. The bottom of the clamps shall be in the same horizontal plane. In one rotation of the eccentric, the minimum distance between clamps shall be  $1.50 \pm 0.01$  in. ( $38.1 \pm 0.25$  mm) (inside measurement) and the maximum distance between clamps  $2.50 \pm 0.01$  in. ( $63.5 \pm 0.25$  mm) (inside measurement).

4.2.2 *Water Tank* made of stainless steel or other noncorrosive material. It shall be of such a size that it can be placed around the clamps, and of such a depth that when in position for use, the top of the pan is at least 2.5 in. (63.5 mm) above the bottom of the clamps, and the bottom of the pan is at least 0.5 in. (12.7 mm) below the bottom of the clamps.

4.2.3 Two systems shall be used to record the number of cycles through which the specimen is flexed. One shall be a mechanical reset counter connected to the movable clamp. The other system shall be electrical (see Fig. 2). The resistance across the electrodes shall be  $7500 \pm 500$  ohms. The sensing electrode shown is inside a leather specimen filled with stainless-steel balls. The common electrode is in a salt solution which is in continuous contact with the specimen during flexing. Switch S when manually closed starts an electrical impulse counter actuated by a micro switch, EC, which makes

<sup>1</sup> This test method is under the jurisdiction of ASTM Committee D31 on Leather and is the direct responsibility of Subcommittee D31.03 on Footwear. This test method was developed in cooperation with the American Leather Chemists Assn.

Current edition approved Sept. 10, 2000. Published October 2000. Originally published as D 2098–62T. Last previous edition D 2098–91(1997) <sup>$\epsilon$ 1</sup>.

<sup>2</sup> *Annual Book of ASTM Standards*, Vol 15.04.

<sup>3</sup> The sole source of supply of the apparatus known to the committee at this time is Koehler Instrument Co., 1595 Sycamore Ave., Bohemia, NY 11716. Telephone: (800) 878-9070. Fax: (516) 589-3815. If you are aware of alternative suppliers, please provide this information to ASTM Headquarters. Your comments will receive careful consideration at a meeting of the responsible technical committee, which you may attend.

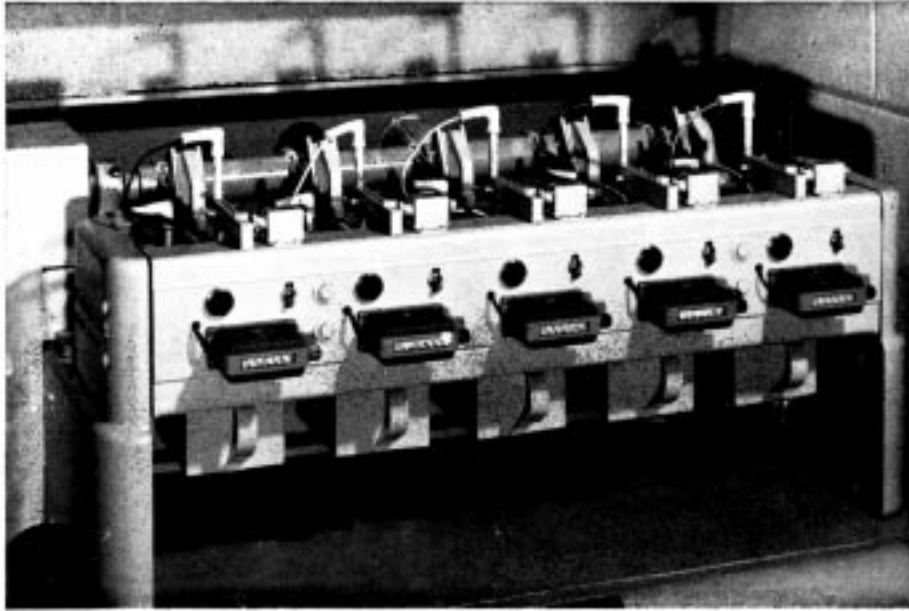

FIG. 1 Dow Corning Leather Tester

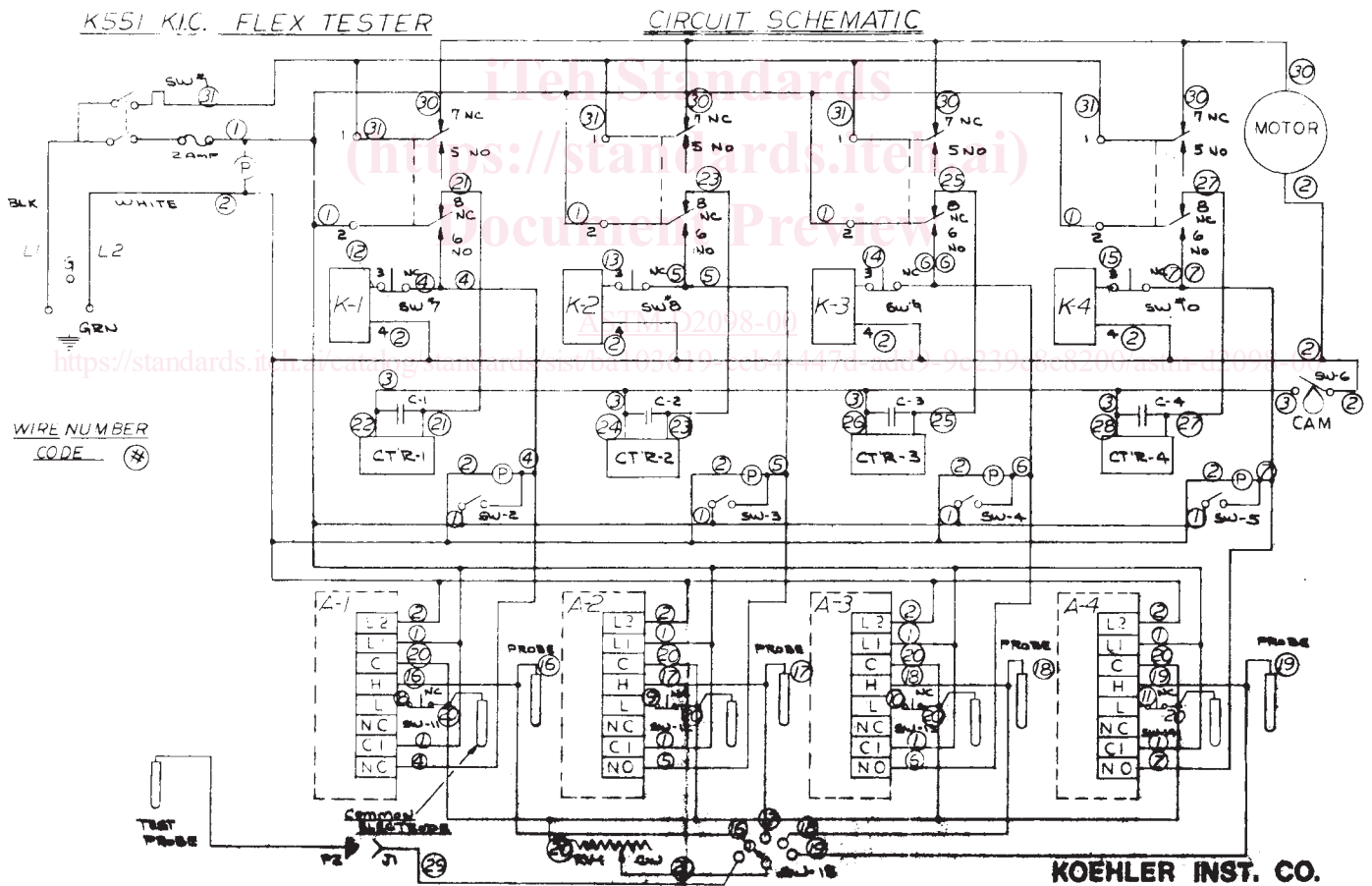

FIG. 2 Electrical Diagram for Dow Corning Leather Tester

contact once on each flex. This records the total number of flexes until initial water penetration. Initial water penetration is detected by a current leakage from the high electrode through

the specimen to the common electrode in the conducting solution. This causes the induction relay to operate, stopping the counter. (**Warning**—It is essential that the electrical circuit